



Products with this symbol (crossed out wheeled bin) cannot be disposed as household waste. Old electrical and electronic equipment must be recycled at a facility capable of handling these products and their waste by-products. If you are purchasing replacement equipment your retailer may offer a 'take back' scheme, or will be able to give details of the nearest approved authorised treatment facility. Proper recycling and waste disposal will help conserve resources whilst preventing detrimental effects on our health and the environment.

WEEE Registered Code: WEE/ED0093VW

**This appliance is not intended for use by persons (including children) with reduced physical, sensory or mental capabilities, or lack of experience and knowledge, unless they have been given supervision or instruction concerning use of the appliance by a person responsible for their safety. Children should be supervised to ensure that they do not play with the appliance.**



Approved CQS ISO 9001:2008



Smith's Environmental Products Ltd,

Blackall Industrial Estate, South Woodham Ferrers, Chelmsford, Essex, CM3 5UW

Tel: 01245 324900 Fax: 01245 324422

Sales E-mail: [sales@smiths-env.com](mailto:sales@smiths-env.com) General Information E-mail: [info@smiths-env.com](mailto:info@smiths-env.com) Web: [www.smiths-env.com](http://www.smiths-env.com)

For Ireland, contact MT Agencies (Ireland) Ltd on Tel: 00353 1 844 3212

SS 80

# Space Saver

Installation and User Guide

Discover the hidden benefits



Space Saver

# SS 80 mm

The following items should be included in the carton:

- ❖ Product complete with stainless steel grille and interconnecting lead.
- ❖ Fixing screws (2).
- ❖ One pair flexible installation hoses.

Accessory grilles which fit in place of a standard grille are available in different colours and finishes. Please consult the price list for details. In the event of any items missing or visible damage, please contact us on 01245 324560.

Please leave this Installation & User Guide and the Guarantee Registration Card with the intended user.

Space Saver is primarily intended for installation in the space beneath kitchen cupboards behind the plinth. However it can also be installed in similar applications such as stair risers and other built-in furniture.

This Space Saver model must not be installed in a bathroom or other high humidity area. Please contact us on 01245 324560 for details of products suitable for these applications.

Space Saver is designed for use on standard two-pipe pumped central heating systems. Pipes are 15mm and either may be used as flow or return. This product is not suitable for one-pipe systems.

In line with best practice, isolating valves (Not supplied) must be fitted to system flow and return pipes. Failure to fit isolating valves may mean that the product is not serviceable in the event of failure.

Space Saver is classified as a fixed appliance and electrical connection should be via a double pole 3A fused spur with a minimum contact gap of 3mm. The fused spur must not be directly above the heater but should be accessible after completion of the installation. If the pre-wired mains cable is damaged, it must be replaced by either the manufacturer, its service agent or

similarly qualified persons. The appliance must be earthed.

To avoid the possibility of vibration, this product must be installed on a flat, even surface.

There must be no rear access to the product after completion of the installation.

To conform with Building Regulations Part L (Part J in Scotland), a remote room thermostat (Smith's Part No. 08-0826) can be used in conjunction with this Space Saver fan convector.

Isolating valves (not supplied) should be fitted to the flow and return pipes on the heater.

The flexible installation hoses supplied are suitable for use with either the 15mm diameter copper pipe or 15mm cross-linked polythene barrier pipe to BS 7291. For all other types of pipe we recommend the use of compression type fittings.

**Please note the guarantee may be invalidated if this product is not installed and used in accordance with this guide.**

## Thermostat Wiring:

1. To link a room thermostat remove the electrical panel on the back of the unit by removing the 2 fixing screws (See below diagram)

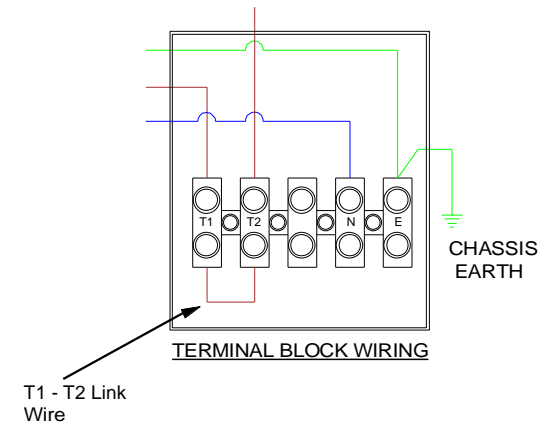
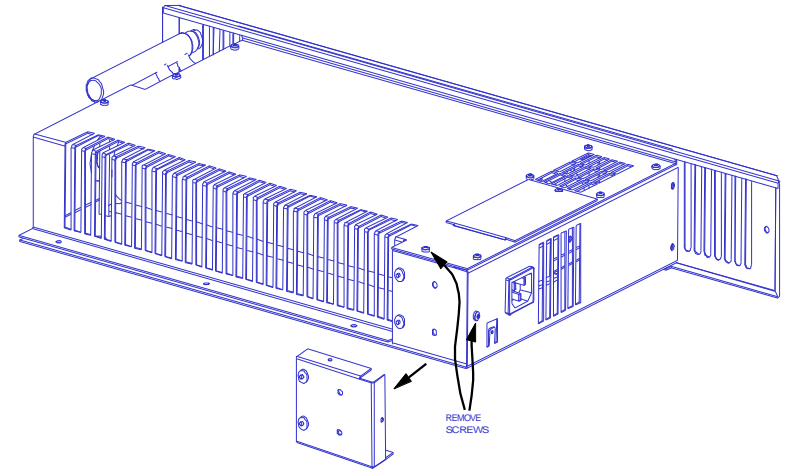

2. Remove T1 – T2 link wire (See above diagram) and connect room thermostat (not supplied) following the manufacturer's instructions.

# User Guide

## SS 80 mm

### User Information

- ❖ Your product is covered by a **free 5-year and labour guarantee**; please complete and return the Guarantee Registration Card to us as soon as possible to ensure that should you require assistance, we can help you quickly and more efficiently.
- ❖ Your Space Saver fan convector is designed to operate as part of your central heating system in the same way as a panel radiator. Providing the heat output switch is left in either the normal (I) or boost position (II) your Space Saver will switch on and off automatically with your central heating system. **Note: This heater will only operate when the central heating system switched on and the water temperature above 35°C** (see page 6)

### How your Space Saver fan convector works

Hot water from your central heating system system passes through a heat exchanger transferring its heat to the aluminium fins. Cooler air is drawn in by the fan and heated as it passes through the heat exchanger before being discharged gently back into the room. This not only gives a more even temperature spread, but will use around 25% less energy and heat up a room in less than half the time of a traditional panel radiator.

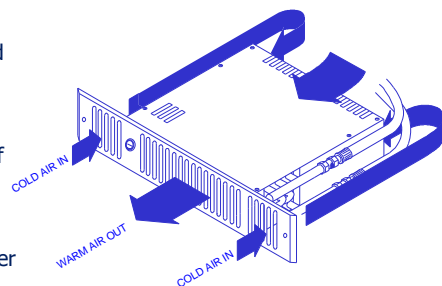

Space Saver includes an internal thermostat that prevents the fan from operating until the central heating system water passing through the heat exchanger reaches 35° C. This prevents the Space Saver circulating cooler air at start up.

### Heating

Ensure your central heating system is on.

Providing the water temperature in the system is more than 35° C and the thermostat controlling your central heating system is calling for heat, your Space Saver will switch on.

In normal operating conditions the Space Saver should be set to normal. If you require a faster warm up, move the switch to boost (II). Moving the switch to (O) will turn off the Space Saver.

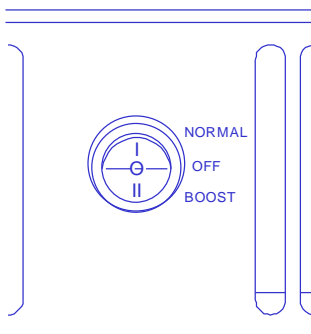

### Fault Finding

This Space Saver is covered by a free 5-year parts and labour guarantee. Please refer to the Fault Finding section on page 5 for advice. In the event of difficulty, please contact us on 01245 324560.

It will be helpful if you do not disconnect the Space Saver from your central heating system.

### Installation Methods

1. This product is designed to be installed into an 80mm plinth; we recommend the use of a knee pad when installing this product.

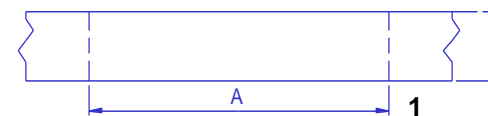

When installing into an 80mm plinth use method **1**.

If installing into a 150mm plinth use method **2** or **3**.

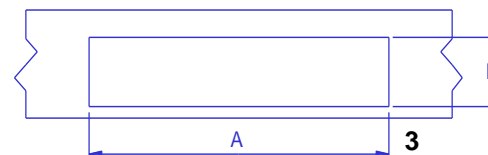
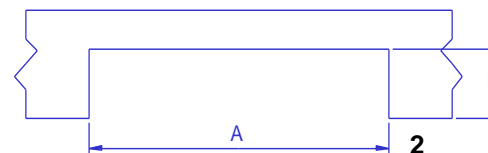

Model	Width A	Height B*
SS 80	505 mm	72 mm

2. Fit isolating valves (not supplied) to the system flow and return pipes (Failure to fit isolating valves may mean that the product is not serviceable in the event of failure), Connect the flexible hoses between system pipework and heater. Open the isolating valves and check for leaks.

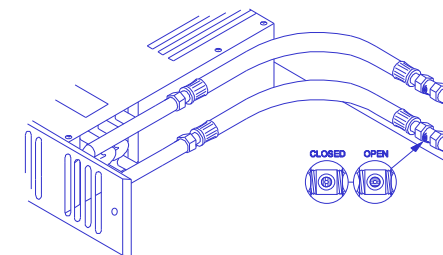

N.B. either pipe may be used on flow or return.

3. Vent air through bleed

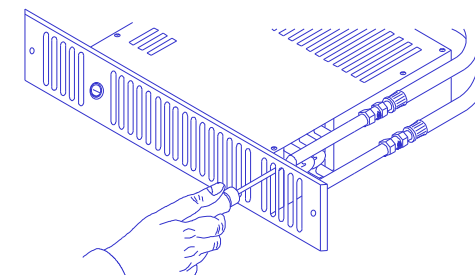

4. Isolate electrical supply and connect the heater electric interconnecting lead to the fused spur (3A). Ensure the fused spur is not directly above the heater and is accessible after installation is complete.

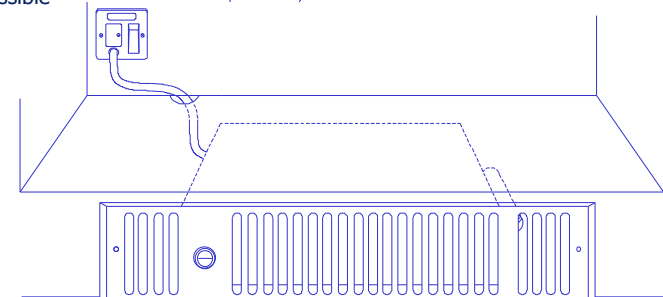

5. Once all electrical connections have been made to the fused spur, connect the heater using the plug on the interconnecting lead to the socket on the side of the heater

For instructions on connecting room thermostat to the heater see page 7

## Commissioning

1. Turn on the electrical supply at the fused spur.
2. Using the switch on the grille set the fan speed from the off position to either low (I) or high (II).
3. Turn on the central heating system.
4. Set any room thermostat/s to maximum.
5. Once the central heating system is warm the unit will run.
6. Balance the central heating system if Space Saver is installed on the same circuit as panel radiators.
7. When the installation is working correctly, remember to reset any room thermostat/s to its normal setting

5. Position heater, making sure the flexible hoses are not kinked and the electrical cable is not snagged.

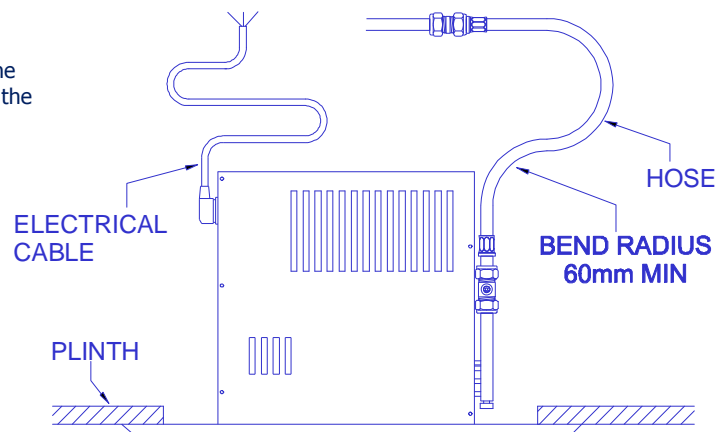

6. Fix the heater to plinth using fixing screw holes located at either end of grille.

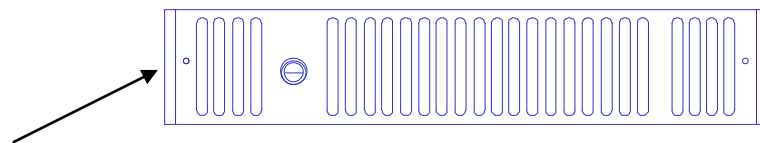

Grille to plinth securing screws

### Cleaning fascia grille:

Use a damp cloth with a small amount of warm soapy water to loosen and remove any dirt or debris. Once contaminants have been removed use a cloth to dry the grille.

## Heat Output Performance

It is recommended that the Space Saver model chosen is capable of maintaining the calculated heat loss at normal heat output (I) enabling the boost setting (II) to be used for faster heat up.

Model	80°C		70°C	
	Normal (kW)	Boost (kW)	Normal (kW)	Boost (kW)
SS 80 mm	0.84	1.05	0.72	0.82

Model	60°C		50°C	
	Normal (kW)	Boost (kW)	Normal (kW)	Boost (kW)
SS 80 mm	0.57	0.66	0.5	0.42

Notes:

Heat outputs tested in accordance with BS4856 using entering water temperature.

## Fault Finding

1. Fan does not run on any switch setting.
  - a). Check the power supply is switched ON.
  - b). Check that the heating system is switched on and if fitted, ensure any room thermostats are calling for heat.
  - c). Check there is no air in the heating system.
  - d). Balance the central heating system if installed on the same circuit as panel radiators and increase the circulating pump speed if required.
  - e). Increase the boiler water temperature
  - f). Check fuse in fused spur.
  - g). Check the wiring connections at the fused spur.

In the event of any difficulty, please contact us on 01245 324560.  
It will be more helpful if you do not remove the product from the central heating system.

## Guarantee Statement

Thank you for purchasing a Smith's heater.

It has been designed and manufactured to the highest quality standards to ensure it gives you efficient and trouble-free service for many years.

To back up our commitment, included with your product is a **free five year parts and labour guarantee**.

This gives you peace of mind that in the unlikely event of the product failing within the first five years, we will repair or replace the product completely free of charge provided the product has been installed, used and maintained in accordance with the instructions.

It is important to register within 7 days. This will ensure you receive a prompt and efficient service, if your product requires attention within the guarantee period. If you do not register your product, you will be required to produce a proof of purchase prior to receiving this service.

If you experience any problems with the use of your product, please contact our **after-sales office** on 01245 324560.

Smith's Environmental Products Ltd manufactures a complete range of heaters for domestic and commercial applications.

If you require any further information, please contact us on **01245 324900** or visit our website at **[www.smiths-env.com](http://www.smiths-env.com)**.

Your statutory rights are not affected by this guarantee.

**Please pull this Registration card from the booklet and fill in all parts and return.**



please fold along here

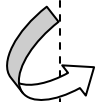

**Smith's Environmental Products Ltd**

**Units 1 & 2 Blackall Industrial Estate**

**Hamberts Road**

**South Woodham Ferrers**

**Chelmsford**

**Essex**

**CM3 5UW**

**Please  
affix  
stamp  
here**

**Guarantee Registration Card  
& Customer Satisfaction Survey**

Dear Customer

We hope our product suits all your requirements; it would help us immensely if you could find the time to fill in this form, your response will help us maintain the quality standards we all expect in today's climate.

Customer name \_\_\_\_\_ Date \_\_\_\_/\_\_\_\_/\_\_\_\_

Email Address \_\_\_\_\_@\_\_\_\_\_

Product Name \_\_\_\_\_

Tick as appropriate

	V Good	Good	Fair	Poor
Product	<input type="checkbox"/>	<input type="checkbox"/>	<input type="checkbox"/>	<input type="checkbox"/>
Delivery	<input type="checkbox"/>	<input type="checkbox"/>	<input type="checkbox"/>	<input type="checkbox"/>
Sales & Ordering	<input type="checkbox"/>	<input type="checkbox"/>	<input type="checkbox"/>	<input type="checkbox"/>
Response to any problems	<input type="checkbox"/>	<input type="checkbox"/>	<input type="checkbox"/>	<input type="checkbox"/>

Comments \_\_\_\_\_  
 \_\_\_\_\_  
 \_\_\_\_\_

Thank you for your time to fill in this survey, the response will help us to serve your needs more effectively. Please return by fax to 01245324422.

Quality Control Manager: Ron Brown ronbrown@smiths-env.com

**User Details**

User Name Mr/Mrs/Miss/Ms/Other .....

Initials ..... Surname .....

Address .....

.....

..... Post Code: .....

Telephone: .....

Product & Model installed (e.g. Space Saver SS5)

.....

Room Installed (e.g. Kitchen): .....

Your details will only be held by Smiths Environmental Products Ltd and used solely to provide customer services and product information.  
 If you do not wish to be contacted, please put an x in the box.

**Installer Details**

Company name: .....

Principal contact: Mr/Mrs/Miss/Ms/Other: .....

Initials: ..... Surname: .....

Address: .....

.....

..... Post Code: .....

Telephone: .....

Date of installation ...../...../.....

Room Installed (e.g. Kitchen): .....

Your details will only be held by Smiths Environmental Products Ltd and used solely to provide customer services and product information.  
 If you do not wish to be contacted, please put an x in the box.