

## Accessories

By fitting optional equipment this product can operate automatically under normal running conditions. The optional controls fit within the casing of the unit and are supplied with easy to fit instructions.

For a full list of optional extras and accessories for you product please see Pages 10-11.

To order accessories or spares please contact either your supplier  
or Smith's Environmental Products Ltd.

Technical designation UVC 90, 120

*Products with this symbol (crossed out wheelie bin) cannot be disposed as household waste. Old electrical and electronic equipment must be recycled at a facility capable of handling these products and their waste by-products. If you are purchasing replacement equipment your retailer may offer a 'take back' scheme, or will be able to give details of the nearest approved authorised treatment facility. Proper recycling and waste disposal will help conserve resources whilst preventing detrimental effects on our health and the environment.*

WEEE Registered Code : WEE/ED0093VW



### **Smith's Environmental Products Ltd,**

Blackall Industrial Estate, South Woodham Ferrers, Chelmsford Essex CM3 5UW

Tel: 01245 324900 After Sales: 01245 324560 Fax: 01245 324422

E-mail: [sales@smiths-env.com](mailto:sales@smiths-env.com) Web: [www.smiths-env.com](http://www.smiths-env.com)

For Ireland (Republic & Northern), contact MT Agencies on 00 353 1 864 3363

In light of our policy of continuous development Smith's Environmental Products Ltd reserve the right to alter specifications without prior notice.

**Manufactured in the**

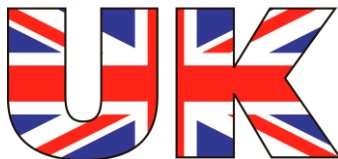

# Caspian Universal Concealed 90 & 120 Series Fan Convector.

Suitable for Low, High &  
Ceiling Level Installations

## Installation & User Guide

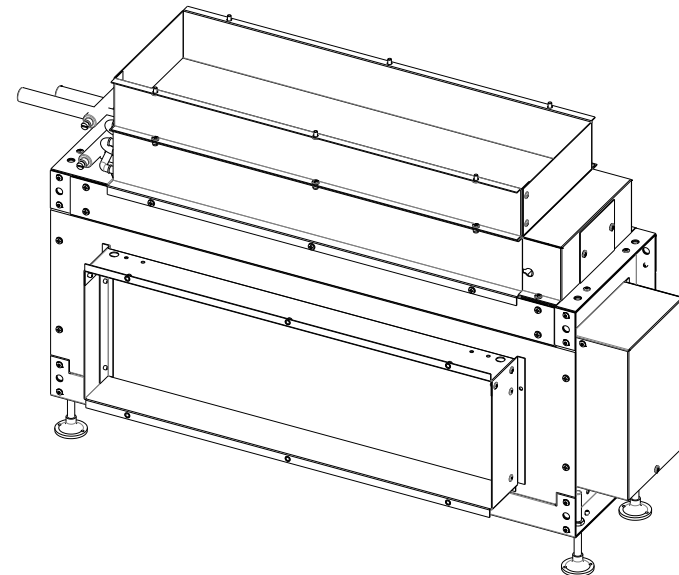

### User Information.

This appliance can be used by children aged from 8 years and above and persons with reduced physical, sensory or mental capabilities or lack of experience and knowledge if they have been given supervision or instruction concerning use of the appliance. Cleaning and user maintenance shall not be made by children without supervision. (refer EN 60335-1 clause 7.12).

## Introduction

The unit is supplied in a standard mode which includes a rectangular air outlet duct, a rectangular air inlet duct (Not fitted) and four mounting feet (Not fitted).

Dependent on the installation you may require right angle ducts, extension ducts, double / triple spigot outlets and grilles, these items and ancillary controls are supplied as accessories (Listed on pages 11 & 12) and should be added to your order if required.

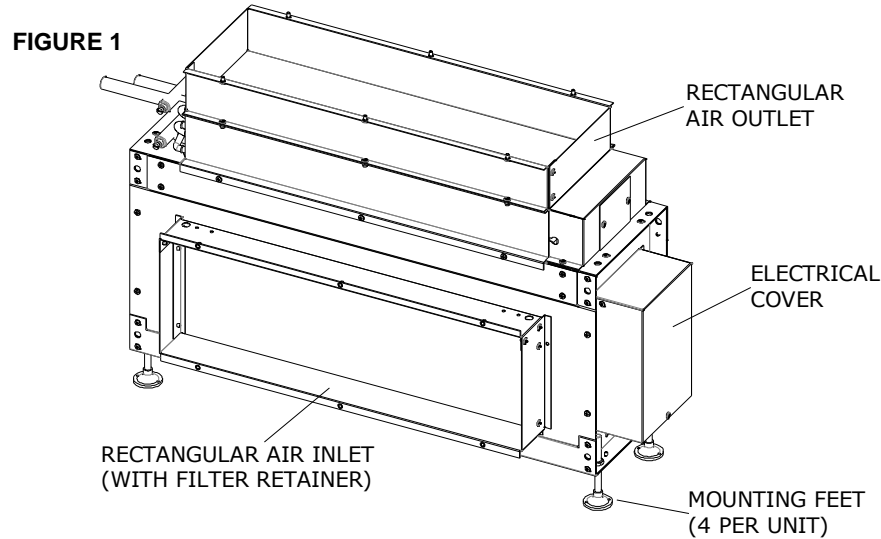

Flexible ducts and other extensions should be sourced from a ductwork supplier (Please refer to page 10 for dimensional diagrams).

This product is designed to heat areas where the unit is to be concealed.

The unit can be mounted on feet (supplied) or hung by threaded rod or chains. When hanging unit by rod or chains ensure fixings are strong enough to take the whole weight of the product and any ancillary accessories used.

Fixing holes are available to accommodate hanging or mounting in any aspect, the unit can be mounted horizontally or vertically in most applications.

Outlet air can be ducted via a straight duct outlet. (Supplied).  
At a right angle, via cranked duct or 200mm double (90) or triple spigot. (120) (optional accessories).

Air draw (return air) can be from either side, bottom, or via right angle cranked duct in any combination.

Suitable applications include- concealed behind walls and panelling, in custom made box sections, above suspended ceilings, concealed over doors, under wooden floors and staging.

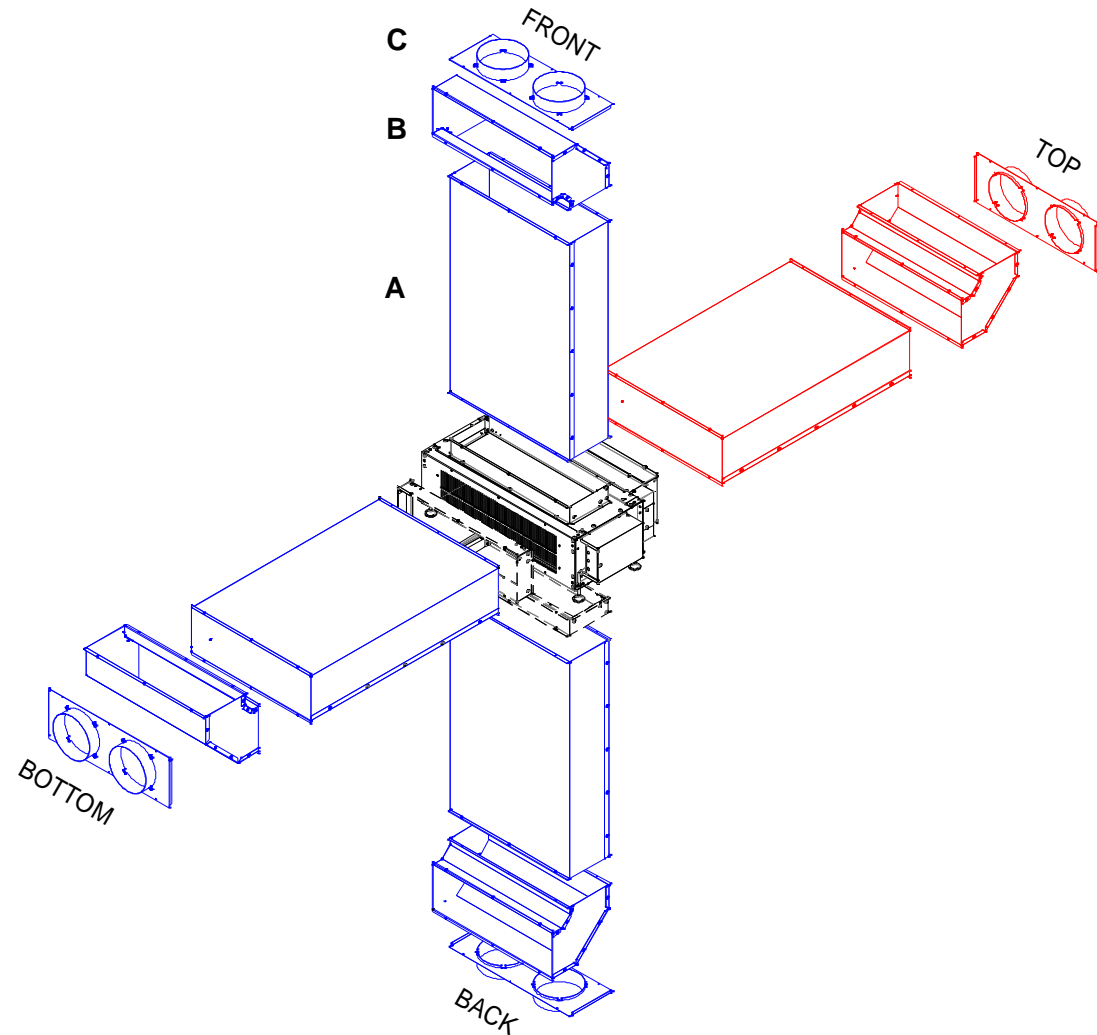

(EXPLODED DIAGRAM WITH BASE UNIT SHOWN IN CENTRE LAYING ON ITS BACK, ALL OTHER PARTS AVAILBLE SEPERATLY)

## Optional extras and Accessories

**Air Inlet:** air inlet should be through one of 3 options (front, bottom, back inlet) shown in blue

If air inlet is not through the front of the unit the filter retainer should be moved to the required position

**Air Outlet:** air outlet must always be through the top of the unit shown in red,

By fitting optional equipment this product can operate automatically under normal running conditions. The optional controls fit within the casing of the unit and are supplied with easy to fit instructions.

<b><u>Inlet / Outlet Ducting &amp; Grilles</u></b>	
<b><u>Straight 1 Metre Duct (Marked as “A” in exploded diagram, See Right)</u></b>	<b><u>STR1MDCT</u></b>
A Straight 1 Metre duct for either inlet/ outlet of the product. May be cut to size if necessary. Available in two sizes (90/120)	
<b><u>90 Degree Duct (Marked as “B” in exploded diagram, See Right)</u></b>	<b><u>90DEGDCT</u></b>
A 90 degree duct used to turn entering/ exiting air of the product, for either inlet/ outlet. Available in two sizes (90/120)	
<b><u>200mm Spigot Adaptor (Marked as “C” in exploded diagram, See Right)</u></b>	<b><u>200SGAD</u></b>
Spigot adaptor that will fit either directly to the heater or an accessory duct. Available in two sizes: Size 90 (x2 200mm Spigots) and Size 120 ( x3 200mm Spigots)	
<b><u>Punched Steel Grille</u></b>	<b><u>PSG</u></b>
Punched steel grille for either inlet/ outlet. Painted in white polyester powder coat (RAL 9010) Available in two sizes (90/120)	
<b><u>Aluminium Linear Grille</u></b>	<b><u>ALG</u></b>
Aluminium framed louvre grille for either inlet/ outlet. Available in two sizes (90/120)	
<b><u>Electrical Controls</u></b>	
<b><u>Proportional Heat Output controller</u></b>	<b><u>PHOC</u></b>
As the room temperature increases to a comfortable temperature the fan speed of the unit will reduce. This replaces the standard unit controller. (This controller is pre-set and non-adjustable)	
<b><u>External Control Harness</u></b>	<b><u>EXTCH</u></b>
Allows for the standard unit controller to be relocated externally from the heater	
<b><u>Adjustable low temperature cut-out</u></b>	<b><u>ALTC T3</u></b>
This enables the end user to precisely select the temperature at which the fans will switch on when combined with different heat sources.	
<b><u>Wall Mounted Controller</u></b>	<b><u>WMCEC</u></b>
This enables the end user to control the fan speed from a wall mounted control.	
<b><u>Miscellaneous</u></b>	
<b><u>Caspian 22mm Flexible Hoses</u></b>	<b><u>CAS22FH</u></b>
Replacement air inlet filters for all models. Available in two sizes (90/ 120)	
For accessories or spares please contact either your supplier or Smith’s Environmental Products Ltd.	

This product must **not** be installed directly in wet rooms or high humidity areas.

This product is designed for use on standard two-pipe pumped central heating systems with a maximum water temperature of 86°C and a maximum pressure of 6 bar (88lbs/in<sup>2</sup>) pipe connections are 22mm and either pipe may be used as flow or return. Suitable valves should be fitted to supply pipework to enable servicing and or balancing.

This product is classified as a fixed appliance and the electrical connection should be via a 3amp fused spur. The fused spur must not be directly below the heater but should be accessible after completion of the installation. All heaters must be earthed. It is recommended that this heater is wired via a remote room thermostat.

To conform with building regulations part I (part j in Scotland) a remote room thermostat can be used in conjunction with this heater. Refer manufactures instructions supplied with the thermostat.

It is recommended that these heaters be fitted with flexible pipe connections to compensate for any movement when used in a hanging installation.

Flexible connections are available as an accessory (see page 10)

### **Controls**

These heaters are fitted with EC motors and a variable speed controller is mounted in the machine. When installation is complete set the controller to the desired speed and refit the electrical cover (See fig 1)

Alternatively for easy access the controller can be fitted outside of the heater in a single wall pattress at a suitable location. The External Control Harness kit is available to facilitate the remote fixing of the controller. (See Page 10, “Electrical Controls”)

Please note the guarantee may be invalidated if this product is not installed and used in accordance with these instructions.

### **Installation guide**

Depending where the heater is to be fitted and the orientation of the heater (Free standing or hung) suitable fixings should be installed.

If free standing the heater we would recommend the use of wooden batons fixed to the floor for the feet to be fixed to. (See “**Surface mounting**” below)

Note if hanging the heater suitable fixings should be used to accept the weight of the unit.

**Do not install directly to the cross frames of a suspended ceiling as they will not be strong enough to take the weight of the heater.**

Prepare apertures for flow and return air ducts where the unit is to be installed i.e. behind wall / panel or suspended ceiling.

Before commencing the installation choose the position of the return air entry to the unit, This can be through one of three options: Front, back or bottom.

The heater comes with a cover plate fitted to the bottom return air entry point.

**If using bottom return air entry** remove bottom blank panel and fit rectangular filter holding duct. Be aware that the slot for the filter should always face upwards.

**FIGURE 2**

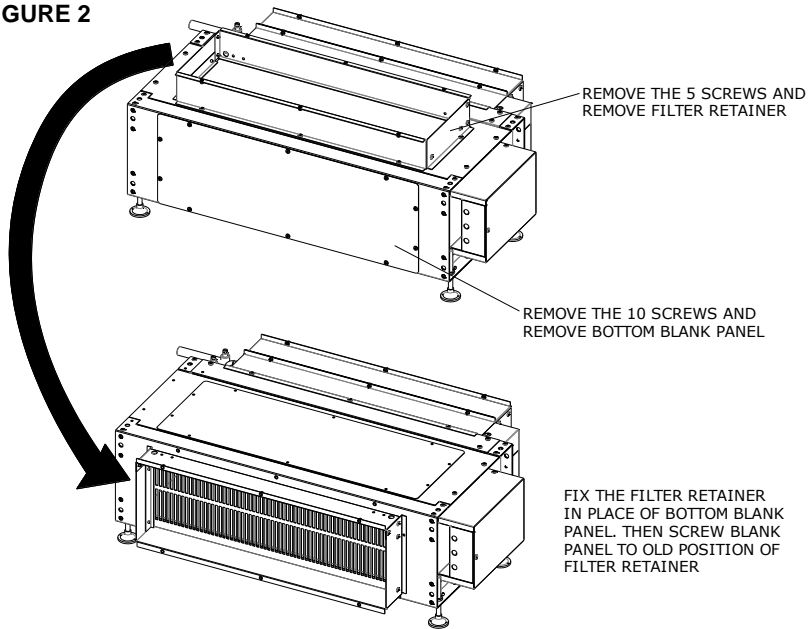

Refit plate to opening on side of unit.

**If fitting duct to rear of unit** remove whole front and rear plates refit on the opposite side.

**FIGURE 3**

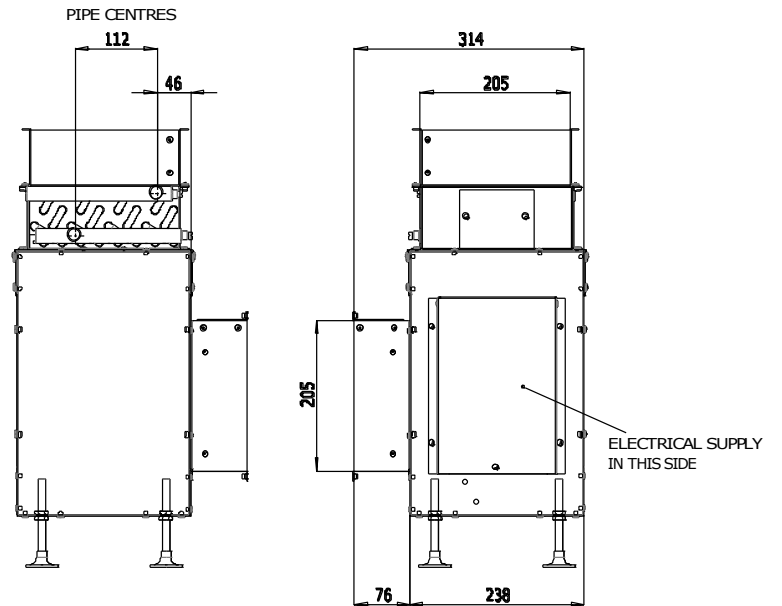
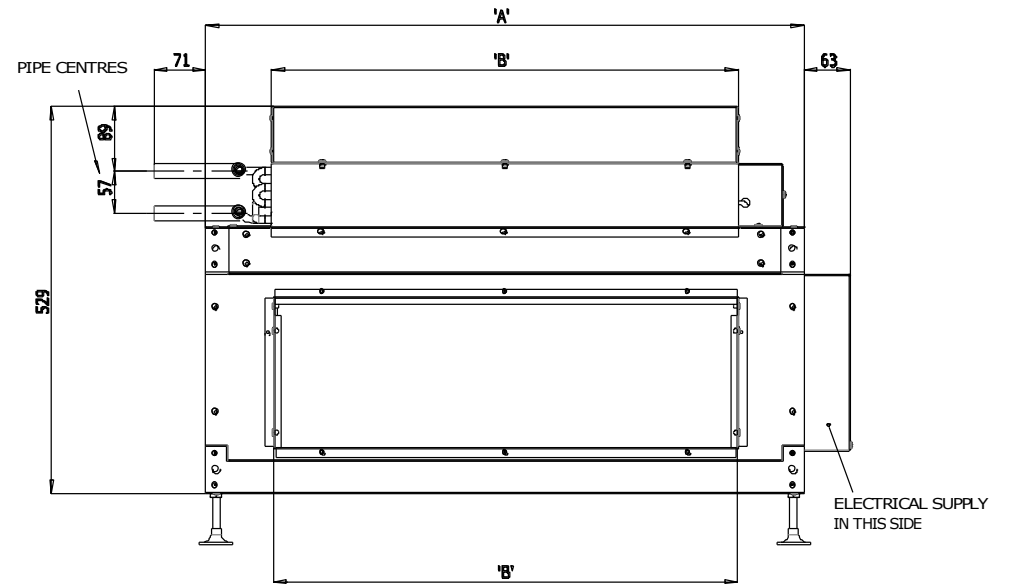
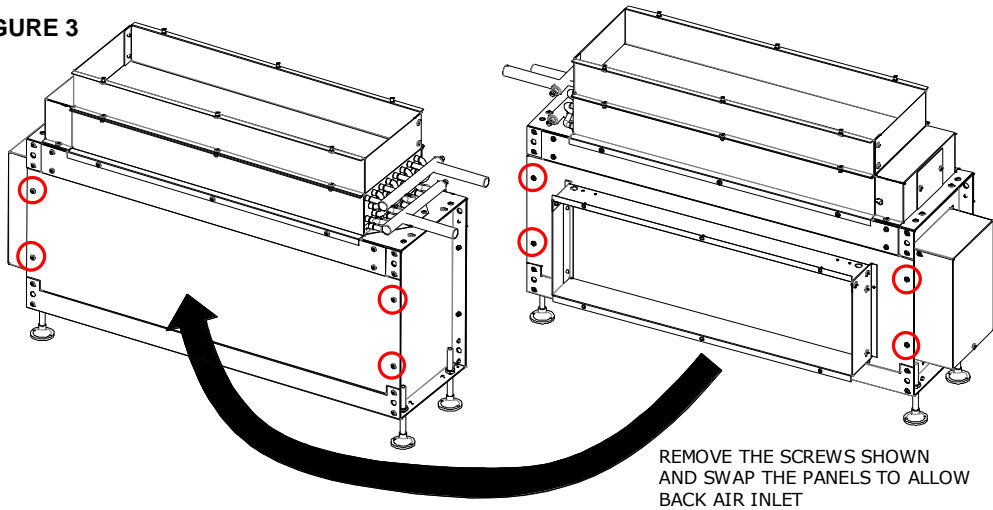

	Size 90	Size 120
"A"	820	1120
"B"	640	940

(Dimensions in millimetres)

## Caspian Concealed Recessed 90 / 120 Wiring Diagram

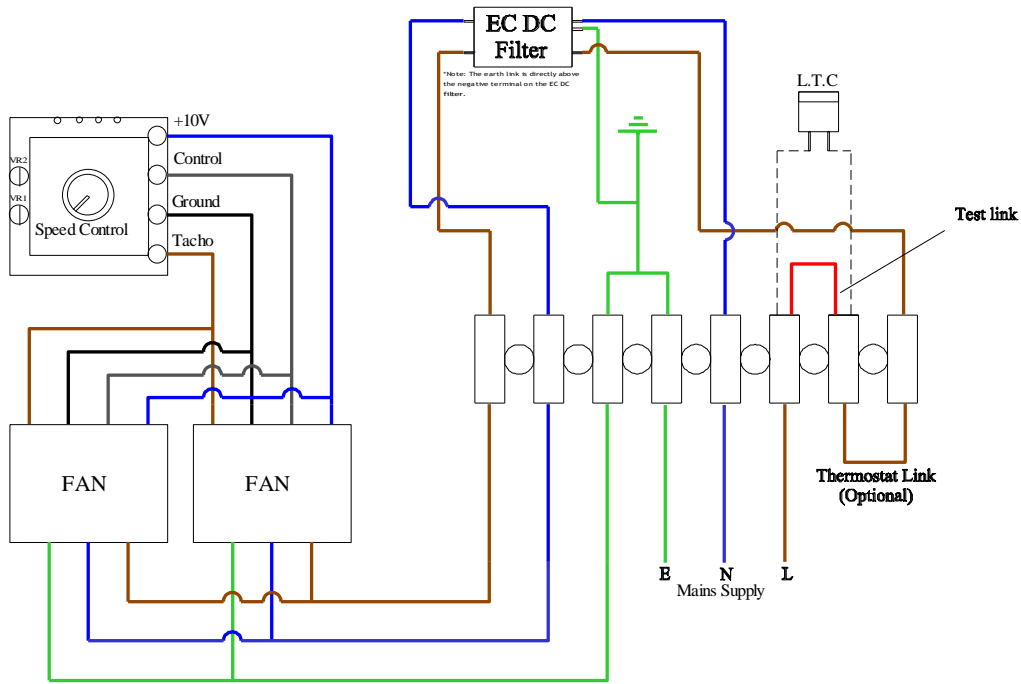

### Test link:

Each heater is fitted with a test link to ensure the correct function of the unit before connecting the heat exchanger to the hot water system.

This link should be removed and the LTC wires (Shown as dashed lines) fitted in its place.

- 1) Isolate the unit from the electrical supply and remove the front panel
- 2) Locate the electrical panel and remove and discard the red test wire.
- 3) Connect the low temperature cut-out (LTC) wires in place of the red test wire
- 4) Re-attach the front panel and re-energise the power supply

**Failure to remove the test link and fit the LTC wires will cause the unit to run continuously**

## Surface mounting

1. Fit feet (supplied) to the unit at the appropriate height and position and drill suitable size holes through the plastic base of the foot to secure.
2. Stand unit on batons (not supplied) and mark position of batons and feet.
3. Remove unit if necessary and fix batons to surface area (floor or other)
4. Mount unit on batons and fix feet to batons with appropriate fixings.
5. Connect unit to pipework (appropriate service valves should be fitted at this point, unless already on flow and return pipework).
6. Open valves from the hot water system to the heater and check for leaks.
7. Identify the electrical (connection) cover on the end of the heater and remove (Shown in figure 1)
8. Connect unit to an appropriate electrical supply via a 3amp fused spur.
9. Connect any ancillary controls to appropriate connections on heater.
10. Refit cover.
11. Switch on electrical supply and heating.
12. Test heater functions are working correctly and remove test link and fit Low temperature cut-out (LTC) wires (See page 8).
13. Switch off electric supply and fit appropriate ducts and / or extensions to the heater and install any front covers or ceiling sections.
14. Install appropriate inlet and outlet grilles.

## Suspended mounting

1. Decide on elevation of heater and note which part of the heater will be facing upwards.
2. Fit suitable fixings to attach the chains or threaded rod to the ceiling or prepared hanging brackets.
3. If using chains fit appropriate hanging eyes to the upside of the unit. (not supplied)



## Guarantee Statement

Thank you for purchasing a Smith's heater.

It has been designed and manufactured to the highest quality standards to ensure it gives you efficient and trouble-free service for many years.

To back up our commitment, included with your product is a **free five year parts and labour guarantee.**

This gives you peace of mind that in the unlikely event of the product failing within the first five years, we will repair or replace the product completely free of charge provided the product has been installed, used and maintained in accordance with the instructions.

It is important to register within 7 days. This will ensure you receive a prompt and efficient service, if your product requires attention within the guarantee period. If you do not register your product, you will be required to produce a proof of purchase prior to receiving this service.

If you experience any problems with the use of your product, please contact our **after-sales office** on 01245 324560.

Smith's Environmental Products Ltd manufactures a complete range of heaters for domestic and commercial applications.

If you require any further information, please contact us on **01245 324900** or visit our website at **[www.smiths-env.com](http://www.smiths-env.com)**.

Your statutory rights are not affected by this guarantee.

**Please pull this registration card from the booklet and fill in all parts and return.**



**please fold along here**

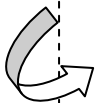

**Smith's Environmental Products Ltd**

**Units 1 & 2 Blackall Industrial Estate**

**Hamberts Road**

**South Woodham Ferrers**

**Chelmsford**

**Essex**

**CM3 5UW**

**Please  
affix  
stamp  
here**

**Guarantee Registration Card  
& Customer Satisfaction Survey**

Dear Valued Customer

We hope our product suits all your requirements; it would help us immensely if you could find the time to fill in this form, your response will help us maintain the quality standards we all expect today.

Customer name \_\_\_\_\_ Date \_\_\_\_/\_\_\_\_/\_\_\_\_

Email Address \_\_\_\_\_@\_\_\_\_\_

Product Name \_\_\_\_\_

Tick as appropriate

	V Good	Good	Fair	Poor
Product	<input type="checkbox"/>	<input type="checkbox"/>	<input type="checkbox"/>	<input type="checkbox"/>
Delivery	<input type="checkbox"/>	<input type="checkbox"/>	<input type="checkbox"/>	<input type="checkbox"/>
Sales & Ordering	<input type="checkbox"/>	<input type="checkbox"/>	<input type="checkbox"/>	<input type="checkbox"/>
Response to any problems	<input type="checkbox"/>	<input type="checkbox"/>	<input type="checkbox"/>	<input type="checkbox"/>

Comments \_\_\_\_\_  
 \_\_\_\_\_  
 \_\_\_\_\_

Thank you for your time to fill in this survey, the response will help us to serve your needs more effectively. Please return by fax to 01245324422.

Quality Control Manager: Ron Brown                      ronbrown@smiths-env.com

**User Details**

User Name Mr/Mrs/Miss/Ms/Other .....

Initials ..... Surname .....

Address .....

.....

..... Post Code: .....

Telephone: .....

Product & Model installed (e.g. Space Saver SS5)

.....

Room Installed (e.g. Kitchen): .....

Your details will only be held by Smiths Environmental Products Ltd and used solely to provide customer services and product information.  
 If you do not wish to be contacted, please put an x in the box.     

**Installer Details**

Company name: .....

Principal contact: Mr/Mrs/Miss/Ms/Other: .....

Initials: ..... Surname: .....

Address: .....

.....

..... Post Code: .....

Telephone: .....

Date of installation ...../...../.....

Room Installed (e.g. Kitchen): .....

Your details will only be held by Smiths Environmental Products Ltd and used solely to provide customer services and product information.  
 If you do not wish to be contacted, please put an x in the box.