

This appliance is not intended for use by persons (including children) with reduced physical, sensory or mental capabilities, or lack of experience and knowledge, unless they have been given supervision or instruction concerning use of the appliance by a person responsible for their safety. Children should be supervised to ensure that they do not play with the appliance.



Products with this symbol (crossed out wheellie bin) cannot be disposed as household waste. Old electrical and electronic equipment must be recycled at a facility capable of handling these products and their waste by-products. If you are purchasing replacement equipment your retailer may offer a 'take back' scheme, or will be able to give details of the nearest approved authorised treatment facility. Proper recycling and waste disposal will help conserve resources whilst preventing detrimental effects on our health and the environment.

WEEE Registered Code: WEE/ED0093VW

Smith's Environmental Products Ltd,

Blackall Industrial Estate, South Woodham Ferrers, Chelmsford Essex CM3 5UW

Tel: 01245 324900 After Sales: 01245 324560 Fax: 01245 324422

E-mail: info@smiths-env.com Web: www.smiths-env.com

For Ireland (Republic & Northern), contact MT Agencies on 00 353 1 864 3363

In light of our policy of continuous development Smith's Environmental Products Ltd reserve the right to alter specifications without prior notice.



Versatile, energy efficient heating

Sterling 1000 series High Level Fan Convector

Models

1000-230V, 1000-12V

INSTALLATION & USER GUIDE

Dear Installer,

The following items should be included in the carton:

- Product complete with cable
- Transformer (1000-12V only mounted inside the product)

In the event of items missing or visible damage please contact us on 01245 324560. We would be most grateful if you would leave this Installation & User Guide and the Guarantee Registration Card with the owner of the property.

Thank you for your co-operation.

Steve Russell
Technical Services Manager

Installation

Please note the guarantee may be invalidated if this product is not installed and used in accordance with this guide.

1. Release the outer casing by removing the screws on the underside of the casing.

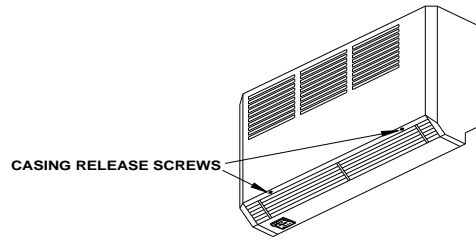

2. Secure heater to the wall using fixings suitable for wall and level. If necessary use packing to compensate for uneven wall surfaces. Maximum recommended installation height is 2.1 metres to the underside of the heater.

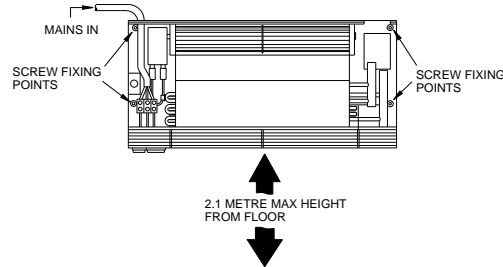

3. Connect the heating system flow and return pipes to the heater pipe work. Do not use soldered fittings to the heater pipe work as the heat generated could damage internal wiring and components. We recommend the use of full flow isolating valves. The valves should be accessible after completion of the installation. We also advise the fitting of an air vent at the highest point on either the flow or the return pipe to remove any air trapped within the system. Check for water leaks. Vent any trapped air from the heating system.

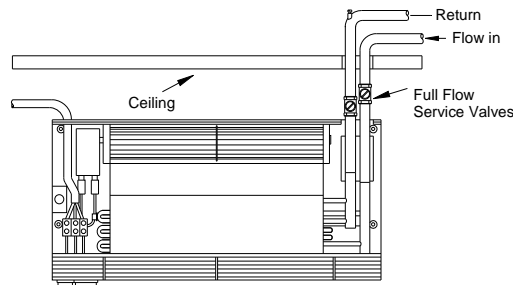

How a Sterling fan convector works

Hot water from your central heating system passes through the heat exchanger transferring its heat to the aluminium fins. Cooler air is drawn in by the fan and heated as it passes through the heat exchanger before being Expelled gently back into the room. Fan convectors use around 25% less energy than a radiator to heat up a room, give a more even temperature spread and achieve the required temperature in much less time.

This heater includes a low temperature cut out thermostat that prevents the fan from operating until the central heating system water passing through the heat exchanger reaches 35°. This prevents Sterling circulating cooler air at start up.

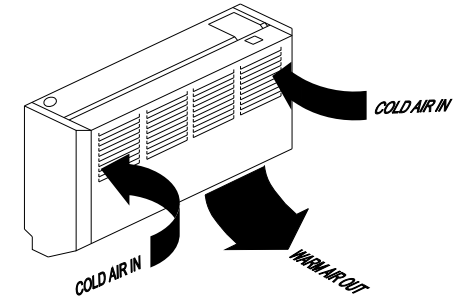

Heating

Ensure your central heating system is on, the heat output switch set to normal I and the fan-only switch set to RED (Heating). Providing the water temperature in the system is more than 38°C and the thermostat/s controlling your central heating system is calling for heat your heater will switch on.

If you require a faster warm up move the heat output switch to boost II. moving the heat output switch to 0 will turn off the heater.

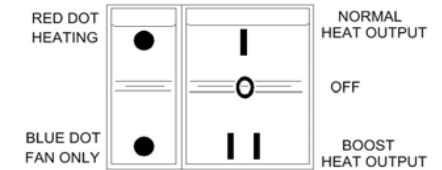

Air Circulation (summer use)

Ensure central heating is off. Set the fan-only switch to **BLUE** and the heat output switch to either **I** or **II**. **Sterling** will run to provide a cooling flow of air. If the heater is being used in conjunction with a room thermostat, the thermostat must be set to maximum.

Fault Finding

This heater is covered by a free five-year parts and labour guarantee. Please refer to the fault finding section of the installation guide for advice. In the event of difficulty please contact us on 01245 324560. it will be helpful if you do not disconnect the heater from the central heating system.

Sterling High Level Fan Convector

Models

1000-230V, 1000-12V

USER GUIDE

Dear Customer,

We are delighted you have chosen one of our products and trust you are satisfied with the installation. We would ask you to take a few minutes to read the User Guide to help you gain maximum benefit from your Ecovector® fan convector. As with all our products your **Sterling** is covered by a free five-year parts and labour guarantee and we would be grateful if you complete and return the Guarantee Registration Card to us as soon as possible. This will ensure that should you require assistance we can deal with you quickly and efficiently.

Thank you for your co-operation.

Steve Russell
Technical Services Manager
01245 324900

P.s Your **Sterling** is designed to operate as part of your central heating system in the same way as a panel radiator. Providing you leave the heat output switch in either the normal I or boost position II and the fan-only switch set to RED your **Sterling** will switch on and off automatically with your central heating system.

Installation Continued. – Electrical connection

Models 1000-230V

Electrical installations for these heaters must only be carried out by a suitably qualified person. All electrical installation connections must comply with BS7671, 1992 and IEE Regulations. Check the voltage on the heater is correct supply for your supply, if in doubt, consult a qualified electrician.

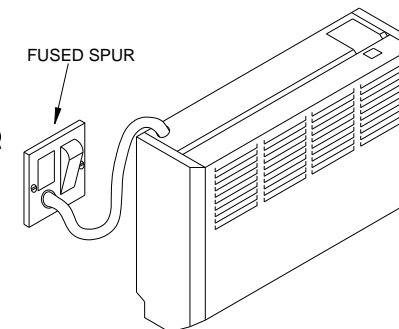

4. Isolate the electrical supply and connect the heater electric cable to the spur (3A). The fused spur must not be directly above the heater but should be accessible after the installation is complete.

Model 1000-12V

This model is designed for use in bathrooms and other high humidity areas. For these applications it is essential that the heater, transformer and fused spur are installed in line with current regulations relative to fixed current equipment in high humidity areas, wet rooms and/or bath and shower rooms. Electrical installations for these heaters must only be carried out by a suitably qualified person. All electrical installations must comply with BS7671, 1992 and IEE Regulations. Check the voltage on the heater is correct for your supply. If in doubt, consult a qualified electrician.

The 12v transformer is mounted within the unit, however if desired it can be mounted external to the unit (for example the loft area) away from the splash area and should be accessible after completion of installation and comply with IEE regulations.

Supply to the transformer must be via a 3 amp fused spur. The fused spur must **not** be directly above the heater but should be accessible after completion of the installation. HL 1000-12V should not be earthed.

4. Isolate the electrical supply and connect the mains side of the transformer to the fused spur.
5. Connect between the 12V side of the transformer and the heater using twin core cable fitted to the product.

Installation Continued. – Final Assembly

6. Refit the outer casing to the chassis attaching the earth bonding connector (not model 1000-12V) to the outer casing.

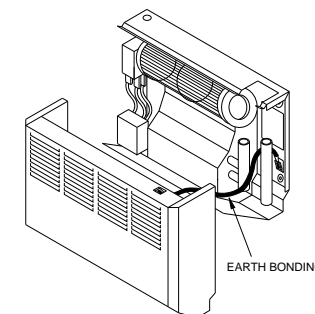

Commissioning

1. Turn on electrical supply at the fused spur.
2. Set the left hand (fan-only) switch to the blue dot and the right hand (heat output) switch to **II**, the fan should run at boost speed.
3. Turn on the central heating system.
4. Set the room thermostat (if fitted) to maximum.
5. Set the left hand (fan-only) switch to the red dot and the right hand (heat output) switch to **I** or **II** – heat will flow within a few minutes.
6. Balance the central heating system if the heater is installed on the same circuit as panel radiators.
7. If the installation is working correctly remember to reset the room thermostat (if fitted) to its normal setting.
8. Please leave this installation & user guide with the property owner for future reference

Remote Thermostat

Fit a thermostat if required. There is a connection facility within the unit. Remove link and attach wires to terminals L1 and L2.

Heat Output Performance

It is recommended that the Sterling High Level model is capable of maintaining

The calculated heat losses at normal heat output (I) enabling the boost settings (II) to be Used for faster heat up.

Model	Heat Output Δt					
	60°C		50°C		20°C	
	Normal	Boost	Normal	Boost	Normal	Boost
	kW (Btu/h)	kW (Btu/h)	kW (Btu/h)	kW (Btu/h)	kW (Btu/h)	kW (Btu/h)
1000-230V	1.0 (3500)	1.4 (4700)	0.9 (3100)	1.1 (3800)	0.4 (1300)	0.5 (1800)
1000-12V	1.0 (3500)	1.4 (4700)	0.9 (3100)	1.1 (3800)	0.4 (1300)	0.5 (1800)

Heat outputs are tested in accordance with BS4856. The temperature of the water in the central heating system will affect the heat output of this heaters. Δt 60°C assumes a mean water temperature of 80°C and a room temperature of 20°C. Δt 50°C assumes a mean water temperature of 70°C and a room temperature of 20°C. Δt 20°C assumes a Mean water Temperature of 40°C and a room temperature of 20°C.

Fault Finding

1. Fan does not run on any switch setting.
 - a. Check the power supply is turned on.
 - b. Check the fuse in the fused spur.
 - c. Check the wiring connections at the fused spur.
2. No heat output on settings **I** or **II**.
 - a. Vent any trapped air from the system (with the central heating system turned OFF).
 - b. Check the central heating is turned ON.
 - c. If fitted ensure the room thermostat is calling for heat.
 - d. Balance the central heating system if installed on the same circuit as panel radiators and increase the circulating pump speed if required.
 - e. Increase the boiler water temperature.

In the event of difficulty please contact us on 01245 324560. It will be helpful if you do not disconnect the heater from the central heating system.

This appliance is not intended for use by persons (including children) with reduced physical, sensory or mental capabilities, or lack of experience and knowledge, unless they have been given supervision or instruction concerning use of the appliance by a person responsible for their safety. Children should be supervised to ensure that they do not play with the appliance.



Products with this symbol (crossed out wheeled bin) cannot be disposed as household waste. Old electrical and electronic equipment must be recycled at a facility capable of handling these products and their waste by-products. If you are purchasing replacement equipment your retailer may offer a 'take back' scheme, or will be able to give details of the nearest approved authorised treatment facility. Proper recycling and waste disposal will help conserve resources whilst preventing detrimental effects on our health and the environment.

WEEE Registered Code: WEE/ED0093VW