

# Sargasso S

An elegant alternative solution to traditional wall mounted radiators, convection heaters and air conditioning systems.



## Features

- Suitable for use in both Standard T-Grid and Micro T system ceilings
- Each panel individually packaged for protection
- Loop panel width 595mm; available in lengths 595mm, 1195mm, 1795mm, 2395mm and 2995mm. Feed panel available as 595mm wide by 2395mm
- Panel performance supported by independent test certification to EN 14037
- For bespoke specifications, including cooling capability please contact us to discuss your requirements

## Benefits

- Create a more comfortable environment for occupants by creating an even temperature distribution across the room
- Save energy and money by achieving a higher perceived temperature than the actual room temperature
- Works well with lower temperature heating systems
- Provide an efficient solution offering a short heating and cooling time
- Installed within a ceiling or high on a wall they maximise wall and floor space
- Silent operation
- No dust/bacteria dispersal offering a hygienic solution
- Maintenance free
- Easy to clean so lower cleaning costs
- Integrated in plasterboard

## Applications

- Offices
- Education
- Healthcare
- Leisure
- Transport
- Industrial

## Finish

Material: Smooth faced panel manufactured from 1.2/2.0mm aluminium with panel edges returned for containment of insulation and increased panel rigidity. Pipe carrier manufactured from aluminium bonded to the panel under heat and pressure to ensure integrity of contact along the length of the panel.

Finish: Polyester Powder coated supplied as standard with a RAL 9010 smooth finish with 20% gloss level; anti-bacterial coating and other colours are available. An anti-bacterial paint finish inhibiting the growth of micro-organisms is available, providing additional assistance in meeting infection control targets.

Insulation: 30mm mineral wool pad sealed in tissue paper with foil face.

## Installation

Suitable for use in Micro T system and standard T-Grid system ceilings. Please note that Sargasso is compatible with regular ceiling profiles, but not compatible with Tegular or Microlook ceilings.

## Suspension:

Suitable for installation from drop rods (not supplied). Panels longer than 1200mm will require 3 fixing locations.

## Specification

To specify state:

Radiant Panel in White (RAL 9010) at 600mm wide x 600mm (or 1200mm, 1800mm, 2400mm, 3000mm) long. As Smith's Sargasso S.

# Sargasso S

An elegant alternative solution to traditional wall mounted radiators, convection heaters and air conditioning systems.

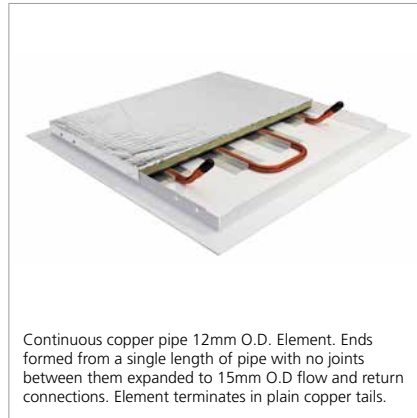
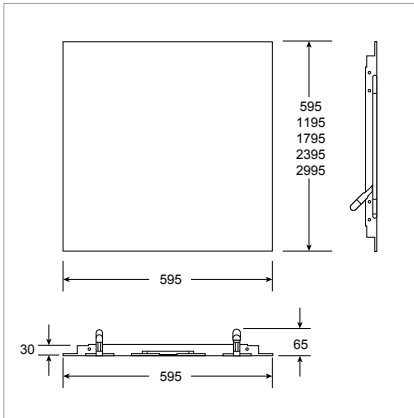

## Heat output (Watts)

Model	Output at $\Delta T$ °C							
	30	35	40	45	50	55	60	65
600 x 600	100	120	140	160	181	203	225	230
600 x 1200	199	240	280	320	361	406	450	460
600 x 1800	299	360	419	481	542	608	675	689
600 x 2400	398	480	559	641	722	811	900	919
600 x 3000	498	600	699	801	903	1014	1125	1149

## Ordering guide

Description	Width (mm)	Length (mm)	Operating Weight including water (kg)	Kg/m <sup>2</sup>	Product code
<b>Sargasso S</b>					
600mm loop panel	595	595	7.9	22.0	HPAE350005
1200mm loop panel	595	1195	15.8	22.0	HPAE350006
1800mm loop panel	595	1795	23.8	22.0	HPAE350007
2400mm loop panel	595	2395	31.7	22.0	HPAE350008
3000mm loop panel	595	2995	39.6	22.0	HPAE350009
2400mm feed panel	595	2395	31.7	22.0	HPAE350010
<b>Accessories</b>					
L brackets 4 required per panel upto 1200mm long, 6 brackets required >1800mm long	-	-	-	-	HPAE355000

As part our commitment to continuous improvement Smith's Environmental Products may change the specifications of its products without prior notification or public announcement. All descriptions, illustrations, drawings and specifications in this publication present only general particulars and shall not form part of any contract. All dimensions are in mm unless otherwise stated.