

# Space Saver

New easy guide

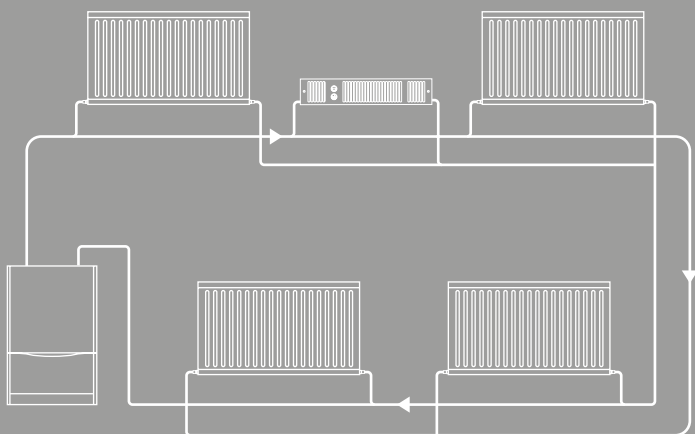

Connecting your Space Saver  
to a central heating system

# Introduction

This document is intended as an easy step-by-step guide to connecting your Smith's Space Saver plinth heater to your central heating system. It is aimed at those who are typically replacing a panel radiator or connecting to an existing central heating system. We hope it offers an invaluable resource to both professional installers and competent DIY'ers alike. It will show you what heating systems are suitable for Space Saver, how to connect your unit to your existing system and help you get the best performance from your heater.

This guide is intended to be read in conjunction with the Installation and User Guide provided with the product. We would stress that should you have any doubts regarding connection of our product to the central heating system you should consult a professional. Details of a local qualified installer can be found by contacting the Chartered Institute of Plumbing and Heating Engineering on 01708 472791 or visit their Website on [www.ciphe.org.uk](http://www.ciphe.org.uk)



# How does it work?

Space Saver is connected to your existing central heating system pipework. Hot water passes through the unit and transfers the heat to aluminium fins. Cooler air is drawn in by an electric fan and heated as it passes through the aluminium fins, and then is gently blown back into the room via a low level grille. This not only gives a more even temperature spread, but will heat the room up in less than half the time of a traditional panel radiator.

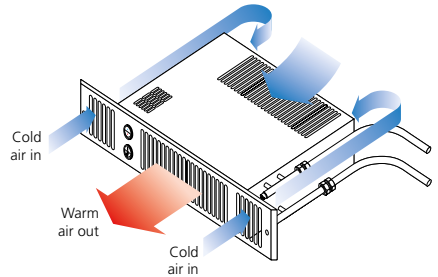

Space Saver Dual models have an additional electric heating element to allow the unit to produce heat when the central heating system is switched off. Only models designated 12V are suitable for use in bathrooms and other high humidity areas.



Space Saver grille - available in a large range of finishes

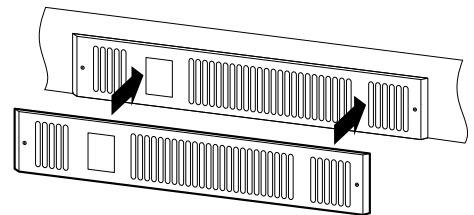

# Is your central heating system suitable?

Nearly all central heating systems, including micro-bore, are suitable for the installation of a Space Saver heater. The only exception is a one pipe system (see diagram below), which has been little used since the sixties and early seventies.

The diagrams below and on page 4 will help you identify your central heating system.

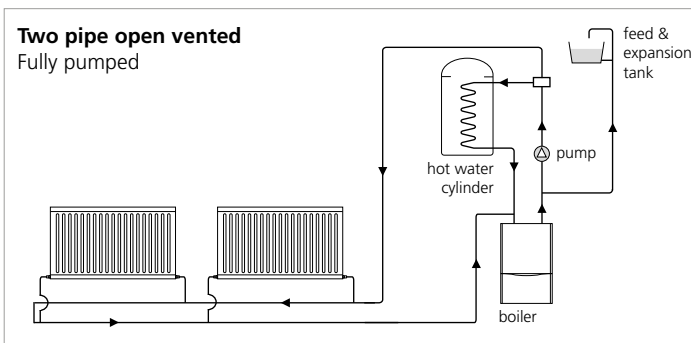
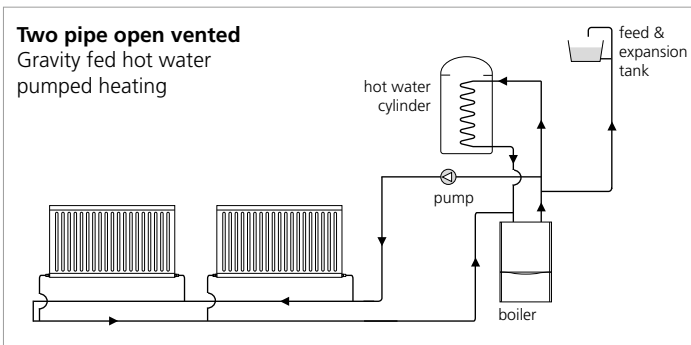
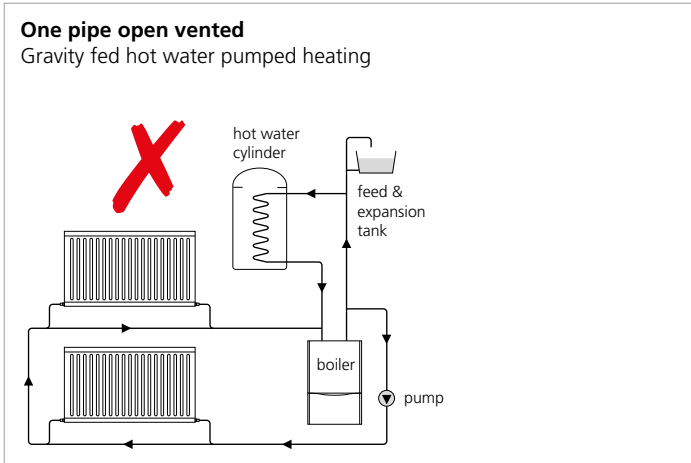

# Is your central heating system suitable?

Nearly all central heating systems, including micro-bore, are suitable for the installation of a Space Saver heater. The only exception is a one pipe system (see diagram below), which has been little used since the sixties and early seventies.

The diagrams below and on page 3 will help you identify your central heating system.

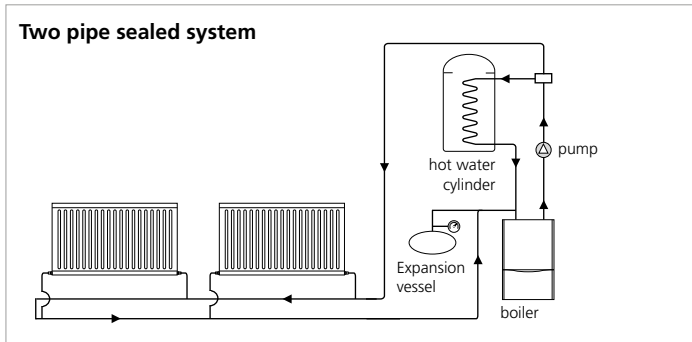

If you have a sealed system or combination boiler it's best to locate the pressure gauge and filling loop which are usually located next to each other. You will also need the manufacturer's recommended system pressure information for when you come to refill the system.

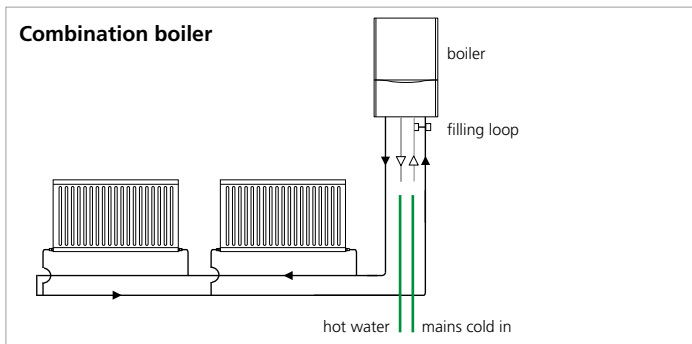

## Microbore

Space Saver can be integrated into heating systems with  $\text{\O}10\text{mm}$  microbore pipework but it is very important that the amount of microbore pipework used to include the Space Saver into the heating system is minimised, ideally to less than 3m. If the amount of microbore pipework is excessive the flow rate through the Space Saver may be compromised and the performance of the Space Saver maybe adversely affected reducing the heat output of the product. It may also prevent the automatic thermostatic may not switch the fan on as the water temperature in the product fails to achieve the required  $38^{\circ}\text{C}$ .

Please refer to the current edition of either the CIBSE Guide B1 Heating or CIPHE Plumbing Engineering Services Design Guide.

# Connecting your Space Saver to the central heating system

Read this guide in conjunction with the Installation & User Guide provided with the product.

Copies are available from the download centre on [www.smithsEP.co.uk](http://www.smithsEP.co.uk) or by calling us on 01245 324560.

Before beginning please ensure you read all the safety and guidance notes within the Installation & User Guide.

You should now have identified your heating system and whether it is suitable to incorporate a Space Saver heater. Your next step is to drain the system of water (see page 6) to enable you to cut into the pipe work at the proposed location of the Space Saver unit.

## Positioning Space Saver

Space Saver is primarily designed for installation in the space beneath kitchen/utility room units, behind the plinth. However, Space Saver can also be installed in other locations such as stair risers and built-in furniture. Only 12 volt models can be used in bathrooms and other high humidity areas. Space Saver can be fitted directly onto the floor (diag A) or raised in a plinth (diag B). If raised, the product should be placed on a stable level platform. Cut the plinth as described in the Installation & User Guide.

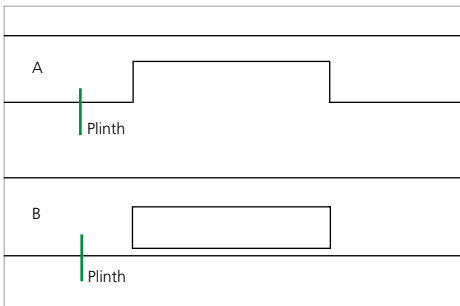

## Positioning the Fused Spur

Now is a good time to work out the best position for the electrical fused spur. Safety regulations require that the fused spur must not be positioned directly above the heater and be easily accessible once installation is complete. Be careful, when placing inside a cupboard, that objects can't hit the switch accidentally. Electrical work should only be carried out by a qualified electrician in compliance with building regulations.

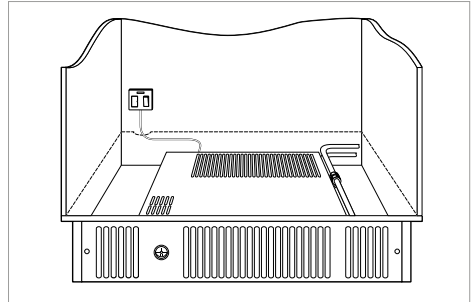

## Positioning the Pipework

The heater connects to your existing heating system's flow and return pipes. If you are unsure what these pipes are, or of the system you have, then refer to the system diagrams on pages 3 of this guide. System flow and return pipes to the heater must, where possible, be at the same level or below the heater's own flow and return pipes. This will reduce the risk of air traps. If this cannot be avoided, ensure that a finger vent is fitted allowing any air traps to be vented.

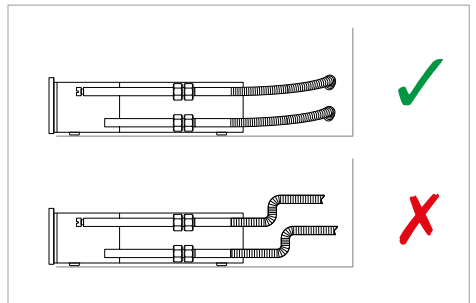

# Connecting your Space Saver to the central heating system

## Draining the system

1. Turn off the electric isolation switch normally adjacent to the boiler.
2. If you have an open vented system turn off the mains water supply to the feed and expansion tank. The stopcock valve is normally located near the tank. If there is no stopcock valve tie the ball cock (float arm) in the up position using a batten to keep the valve closed.

For combination boilers and system boilers, please refer to manufacturers instructions for draining and refilling.

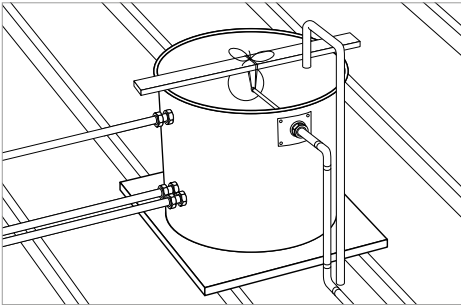

3. Attach a length of hose to the main draincock, usually located on the return pipe near the boiler. Place the other end of the hose to a suitable drain. Open the draincock with a key or adjustable spanner and the system will start to drain.

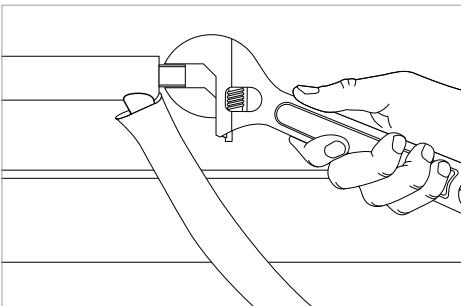

4. Water may be held in the radiators due to the vacuum that is created. To release the water, work from the highest radiator down and open the bleed valves on each radiator to release the trapped air.

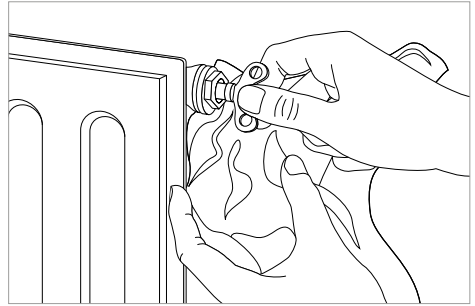

5. Close the bleed valves and the water will continue to drain from the system.
6. Lastly drain any inverted pipe loops. Pipes are often run through ceiling voids and drop down walls to individual radiators. This is called an inverted pipe loop. Each loop should have its own draincock. It is only necessary to drain the inverted loop.

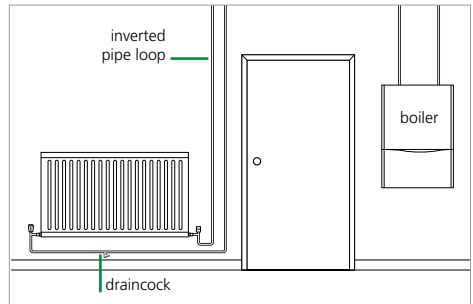

## Connecting the Space Saver

1. Cut and prepare the pipework and connect the heater as detailed in the Installation & User Guide.

## Refilling the heating system

### IMPORTANT

We recommend the use of central heating protectors as these provide long term protection of domestic central heating systems against internal corrosion. If your system has been treated with a central heating protector you should refer to the manufacturer's instructions for topping up and refilling your heating system. Information regarding previous treatment may be with your heating system installation and user guides, on a label near the boiler or if fitted, on a label near the feed and expansion tank.

Untreated systems must be thoroughly cleansed and flushed before treating as existing debris can damage the installation. If in doubt seek professional advice.

1. First check that you have closed all the draincocks and radiator bleed valves.
2. Turn on the supply to your system. If you have an open vented system turn on the valve to the expansion tanks or untie the ballcock. If you have a sealed system your system feed will most likely be located at the boiler.
3. In an open vented system the water will stop filling the expansion tank when the system is full. In a sealed system the system is full when you reach the required pressure as recommended by your boiler manufacturer.
4. As the system fills up air will be trapped in the top of the radiators. You will have to bleed each one, this time starting from the lowest level radiator and working upward. You may also have to bleed the circulating pump.
5. As you bleed the air out of the radiators it will need to be replaced by water. In an open vented system this will be fed automatically, but in a sealed system you will have to let more water in to keep the pressure at the correct level. It's a good idea to have two people during this procedure, one bleeding the radiators and one topping up the water.
6. Check all draincocks and bleed valves for signs of leakage and tighten if necessary.

## Completing the Installation

1. Refer to the Installation and User Guide to complete the commissioning of your Space Saver.

## Balancing the central heating system

The balancing of the system should be carried out by a qualified person; the following notes are for guidance only.

The balance of your central heating should not be affected by installing a Space Saver as part of the system. If however you get little or no heat output from the Space Saver heater it may be that the balance of the system was not correct prior to the installation.

Prior to balancing, you should:

- a. Check the power supply is switched ON.
- b. If fitted, ensure the room thermostat is calling for heat.
- c. Increase the boiler water temperature.

The purpose of balancing is to achieve equal heat distribution and heat output across all heat emitters (radiators, etc) on your central heating system. Generally, upstairs radiators get hotter quickest because hot water is lighter than cold water and so naturally rises. Consequently, radiators that are farthest from the boiler, and those at the lowest level, will need a larger volume of hot water.

To achieve the correct balance, it is necessary to restrict the flow of water through each radiator by adjusting the lockshield valve. For best results, the temperature of water leaving the radiator should be 10% lower than that of the water entering the radiator. This will ensure maximum efficiency and give a longer life to the boiler.

The Space Saver within your system does not need balancing but you should ensure the isolating valves supplied are fully open.

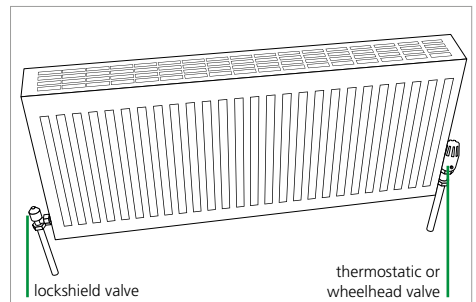



### **Happy to help**

Smith's Environmental Products Ltd is one of the leading manufacturers of heating and cooling products in the UK. We are committed to achieving the highest standards and our faith is supported by a free five year parts and labour guarantee with every product. Our customer service is second to none and we are happy to offer any help and guidance that you might need.

### **Stockists**

All products are available nationally from Builders' Merchants, Plumbers' Merchants, Heating Equipment Distributors and Kitchen Equipment Distributors. In the event of difficulty, please contact us or visit our website [SmithsEP.co.uk](http://SmithsEP.co.uk) for details of your nearest stockist.

### **Information and advice**

Full technical specifications and list prices is available to download from our website or in hard copy from our office. Also available on our website are price lists, individual product data sheets, installation & user guides, where to buy, who to contact and a media centre.

Alternatively contact our office 9.00am to 5.00pm Monday to Friday.

As part our commitment to continuous improvement Smith's Environmental Products may change the specifications of its products without prior notification or public announcement. All descriptions, illustrations, drawings and specifications in this publication present only general particulars and shall not form part of any contract. All dimensions are in mm unless otherwise stated.

**To view the full product information  
download the datasheet at:  
[www.SmithsEP.co.uk](http://www.SmithsEP.co.uk)**

For product information, customer services or sales support call us on **+44 (0) 1245 324900**

For the Republic of Ireland, contact MT Agencies on 01 864 3363

**Sales: [sales@SmithsEP.co.uk](mailto:sales@SmithsEP.co.uk)  
General information: [info@SmithsEP.co.uk](mailto:info@SmithsEP.co.uk)**

Smith's Environmental Products Ltd  
Blackall Industrial Estate, South Woodham Ferrers,  
Chelmsford, Essex CM3 5UW

**[SmithsEP.co.uk](http://SmithsEP.co.uk)**

**[@SmithsEP\\_UK](https://twitter.com/SmithsEP_UK)**

**[#ThinkSmiths](https://www.facebook.com/ThinkSmiths)**

Issue 001 | February 2018