

Solano[®] Eco

Installation, commissioning
and user manual

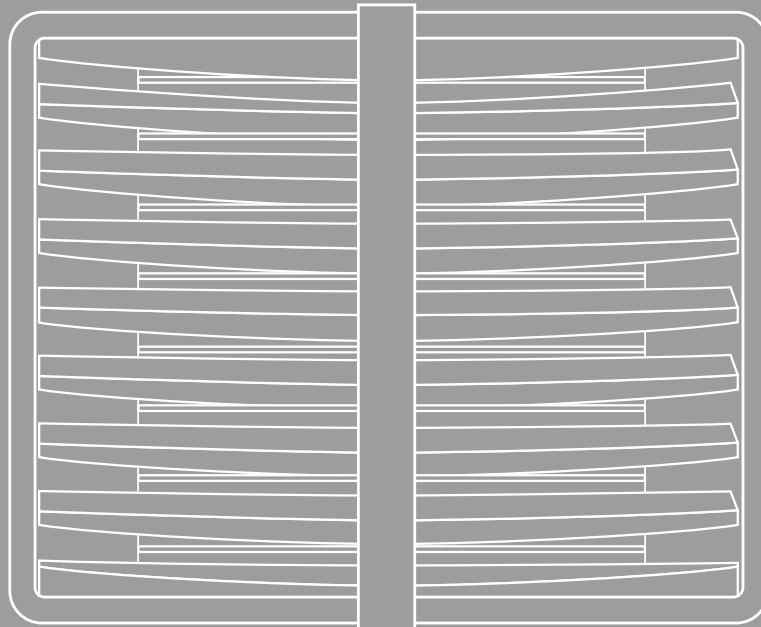

Unit heater

Contents

Introduction	2	Technical data	8
		Electrical connection diagrams	14
Product dimensions	2/3	Panel Intelligent - programmable controller manual	16
General information	4		
Assembly	4	Registering your product	18
Electrical installation	6	Disposal	18
Water installation	6	After sales and spares	18
Automatic Control - installation	7		
Operation	7		
Maintenance	7		

1. Overall information

Solano heating and ventilation devices are designed to be applied in the buildings of small and medium capacity, such as: production and warehouse halls, car showrooms and service stations, sports halls and stadiums, sacral buildings and churches, retail stores and wholesales outlets, agricultural facilities and exhibition halls. Solano provides a dedicated solution for connection to low water temperature sources (for example condensing boilers and industrial heat pumps). Main advantages of Solano are: high temperature of outlet air is generated by low temperature of water supplied to a unit, maximum use of the heating coil surface - new geometry of coil construction (enhanced fins size, lower space between fins), optimised flow rate of heated outlet air - in effect high air exhaust temperature generated on each speed of fan.

2. Dimensions

Solano Eco 1, 2, 3 and Mix 1

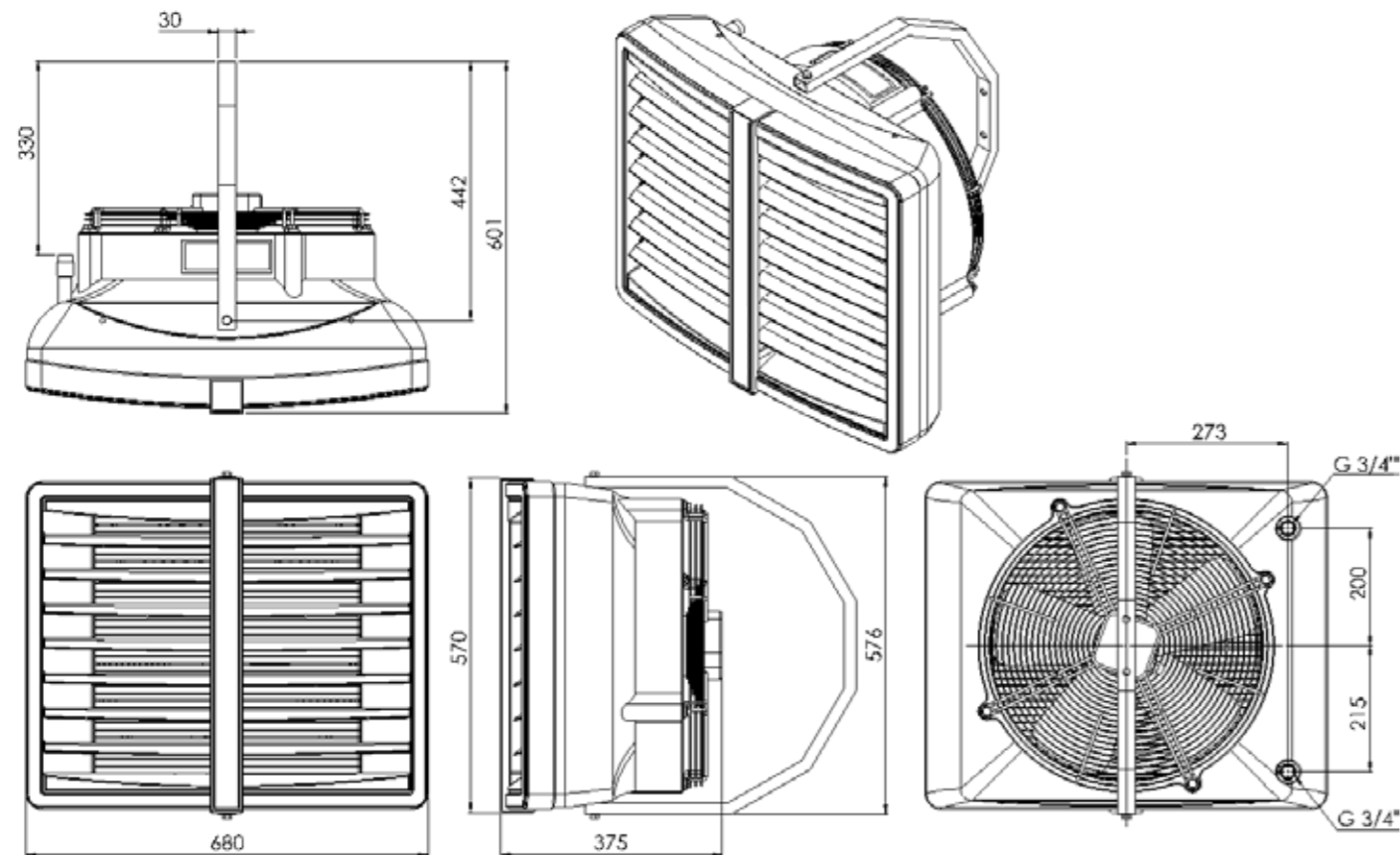

Solano Eco Max 1, 2, 3 and Mix 2

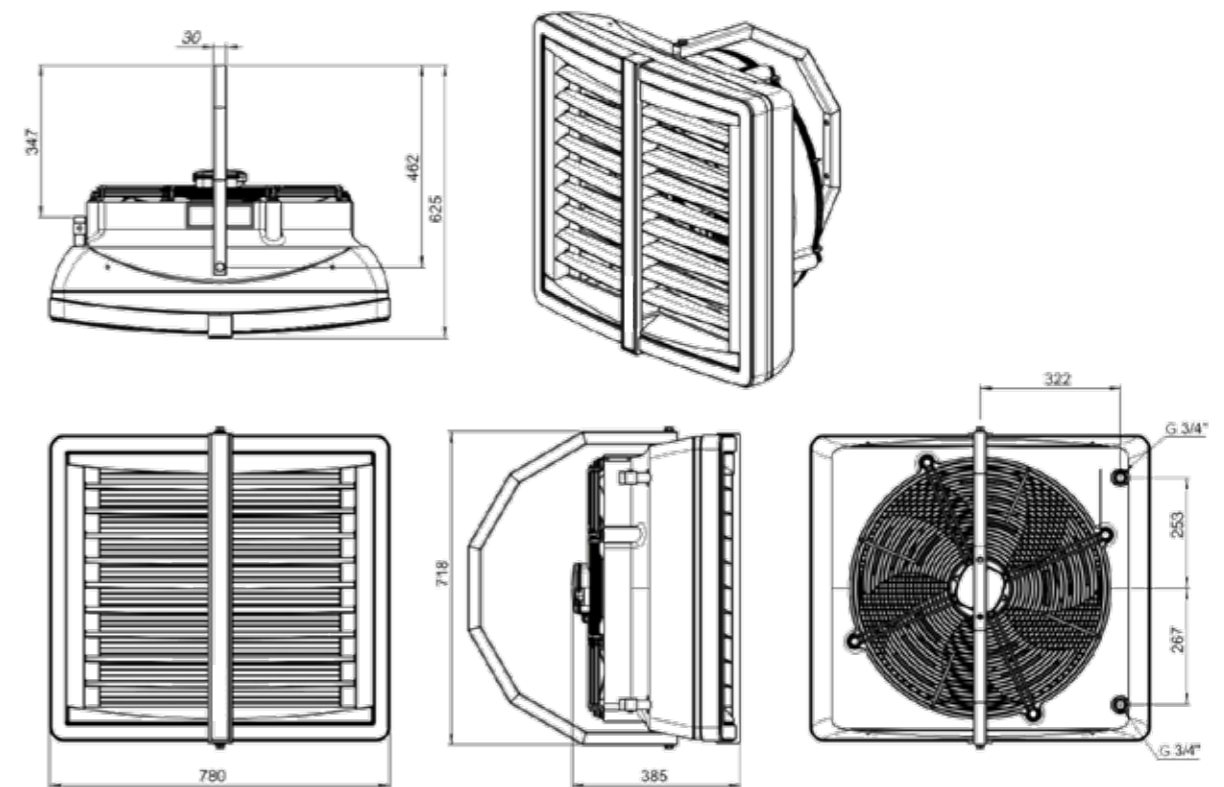

Elements of the Solano devices

- Casing made of highly resistant EPP (expended polypropylene) material
- Regulated louvres
- 3 step axial fan 350 mm, 450 mm or 550mm dimension; protected from direct access to revolving elements with safety netting
- Heat exchanger – (Cu/AL) made of copper tubes placed in an aluminium lamellar exchanger/block with stub connection 1/2", 3/4". Stub connections are equipped with air-release valves and water agent release

	Heater Eco 1	Heater Eco 2	Heater Eco 3	Heater Eco MAX 1	Heater Eco MAX 2	Heater Eco MAX 3	Heater Eco MIX 1	Heater Eco MIX 2
Heat output range*	kW	10-35	15-50	20-70	25-70	35-95	40-120	-
Heat output (90/70°C) / ΔT air temperature increase**	kW/°C	23kW/18°C	39kW/33°C	50kW/48°C	55kW/30°C	74kW/49°C	94kW/60°C	-
Heat output (70/50°C) / ΔT air temperature increase**	kW/°C	16kW/13°C	26kW/22°C	35kW/34°C	40kW/22°C	53kW/35°C	68kW/44°C	-
Heat output (50/30°C) / ΔT air temperature increase**	kW/°C	9kW/8°C	13kW/11°C	20kW/20°C	25kW/14°C	32kW/21°C	42kW/27°C	-
Max air output - III speed	m³/h	3900	3350	2950	5700	5600	5100	4800
Sound level VIII speed****	dB (A)	44/52/62	41/50/60	39/48/60	41/50/59	40/48/58	40/48/58	36/44/54
Number of coil rows		1	2	3	2	3	3	-
Max working pressure	Mpa		1.6			1.6		-
Max airflow range*****	m	24	21	19	26	25	23	13***
Diameter of connection nozzles	inches		3/4"			3/4"		-
Power supply	V/Hz A		230/50 1.08A			230/50 2.2A		230/50 1.08A 230/50 2.2A
Motor power	W		250			520		250 520
Motor speed	rpm		1350			1380		1350 1380
Protection class IP			IP54			IP54		IP54
Weight without water/with water	kg	10.8/11.9	12.7/14.8	14.5/16.9	23.6/25.2	25.2/27.4	25.5/28	9.2 15.8

* presented heat output for water agent temperature range 50/30°C – 120-90°C, air inlet temperature 0°C, III speed.

** for air inlet temperature 0°C

*** max height of installation for vertical airflow, max working area 380 m² for HEATER MIX 1 and 450 m² for HEATER MIX 2 **** measured in distance of 5m

***** Horizontal range of isothermal steam at velocity of 0,5m/s

3. General information

Solano heating and ventilation devices are manufactured in compliance with standards concerning quality, ecology, utility and work comfort. Solano devices are delivered ready-to-use in a cardboard package that is to protect from mechanical damages during transit. The package consists of: the device, wall mounting bracket, the Manual (Operation and Maintenance Documentation) and Guarantee. If the optional automatic control ordered, it shall be delivered in a separate package. Make sure all the aforementioned elements are in the package immediately after the delivery. In the absence of any element, please advise Smith's immediately.

ATTENTION!

- Before mounting read the manual carefully and adhere to the rules concerning the mounting procedures. Failure to do so, may result in inappropriate functioning of the device and the loss of the guarantee rights.
- Pay special attention when working with electrical elements of the device.
- Any installation operations must be carried out by qualified persons with appropriate authorisations

4. Assembly

Prior to any installation procedures, take the following aspects into consideration: easy access for maintenance works, access to water and electrical installation, appropriate air distribution in a room.

Each Solano unit is equipped with a set of 2 interchangeable colour inserts; in order to change the colour, remove the insert from the front panel and place the desired one back in place.

It is advisable to mount the device to the wall or the ceiling on original mounting brackets, supporting mount pins (not delivered with the device) or supporting constructions (shapes and dimensions of the supporting construction may be individually designed in compliance with durability and strength requirements).

In case of mounting to the ceiling, pay attention to the fact that air-release/venting of the device may be difficult so it is advisable to place vent at the highest point of the pipework.

The device may be mounted to the wall with the use of a mounting bracket at the angle of 0°, 30° or 60°. A mounting bracket holder is made of curved profile. It has two holes for vertical assembly. Assembly to the wall and/or to the ceiling is possible at different angles but it requires making necessary holes in the holder.

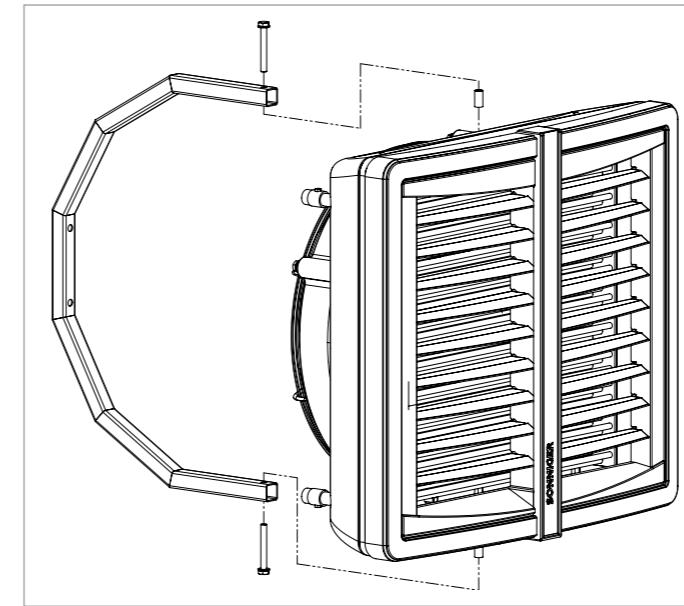
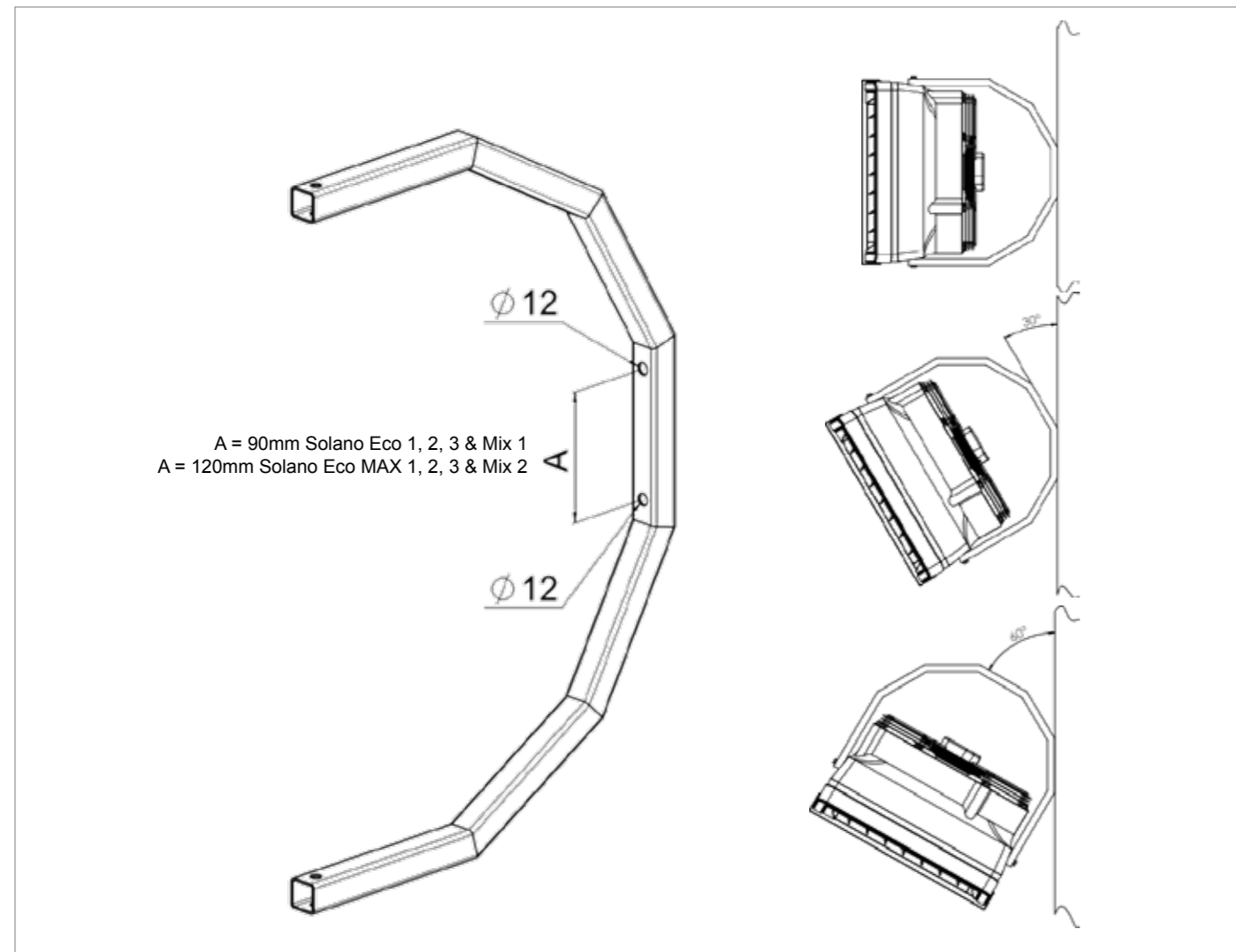

Mounting bracket to the Solano

The bracket set consist of: a holder, two sleeves, two M8 screws and washers.

In order to mount the bracket, drill two Ø12-13mm holes in places visibly marked on the casing.

Insert sleeves into drilled holes and place the bracket in. The included holder must be screwed with M8 screws with washers.

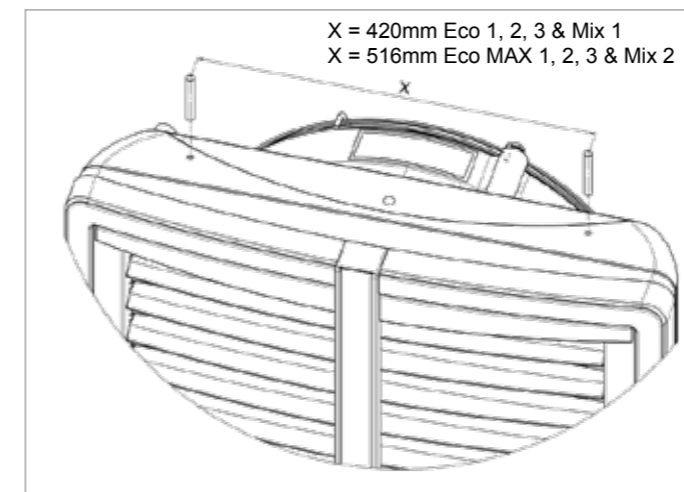

Installation of mounting pins

To mount the heater to the ceiling, use M8 mounting pins.

Drill two Ø8-9mm holes in places visibly marked on the casing.

Mounting pins may be screwed into the frame not deeper than 20mm.

ATTENTION!

- While drilling the holes in marked places be careful not to damage the coil by going deeper than 20mm!

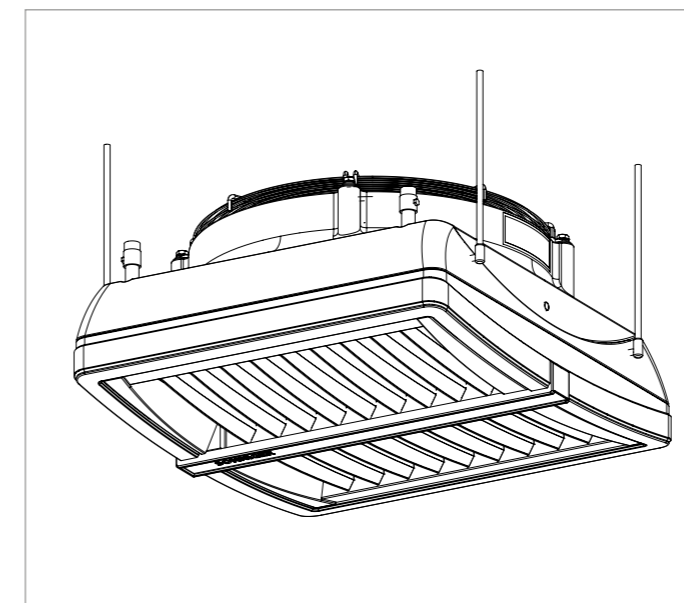

Assembly of Solano MIX air mixer

To mount Solano MIX air mixer to the ceiling, use M8 mounting pins.

Drill two Ø8-9mm holes in places visibly marked on the casing.

Mounting pins may be screwed into the frame of a heat exchanger to the maximum depth of 20mm. Mounting pins and connecting elements are not included with the unit.

NOTICE!

- To sustain proper functioning of the device keep a safe distance - 200 mm from its sides and 300 mm from its backside to the fan

5. Electrical installation

The electrical installation and connection to power supply must be done in compliance with the existing regulations and standards for building industry.

The fan's engine is equipped with the internal temperature limit fuse protecting the engine from its overheating.

The unit set does not consist of: a feeding cable, a master switch (see diagram)

The electrical installation must be done by an authorised person, acquainted with the Manual. The connection of the feeding cable and master switch must be done in compliance with electrical diagram (with or without the automatic control, depending on the option chosen). Any and all damages incurred as a result of the aforementioned causes are not provided with the Guarantee and the user will be charged with any costs of the device exchange. The connection of the automatic control should be carried out in accordance with the electrical diagram.

In case of any doubts or problems, unplug the device and contact the device's installer or Smith's Authorised Service.

6. Water installation

The installation of the unit should be done in a way enabling maintenance service; on both stub pipes manual closing valves should be installed in order to cut off the device. Feeding cables of the heater shall be connected in accordance with the symbols/markings on the casing (inlet/outlet). In case of electromagnetic valve (with the option of the automatic control) it should be installed on the outlet as it may be damaged otherwise. When the pipework is being connected to the exchanger, secure the connections of the heater from oscillating torque (see figure) that may cause leakage in the exchanger.

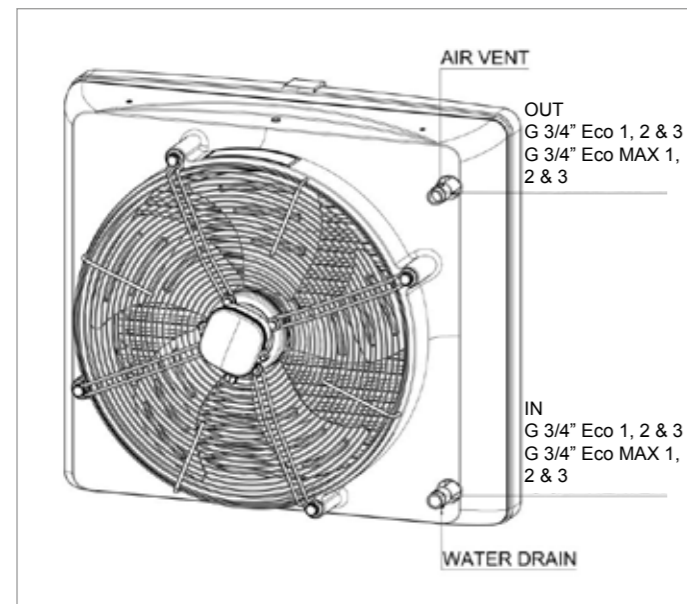

Heating medium

The connector pipes are at the back of the device.

When connecting the hydraulic pipes/connections, make sure you secure the connector pipes against rotational torque.

Notice that the connector pipes are not strained by the pipes.

The valve of heating medium is on the supply pipe and the vent is on the return pipe.

Use flexible connections to allow the heater to be turned to the sides. Depending on the flexible connections, the maximum turn is 70° - for Solano Eco MAX, 78° - for Solano Eco 1, 2 and 3 to both sides. Figure shows maximum angle to one side and 50° to the other with minimal distance left for connections.

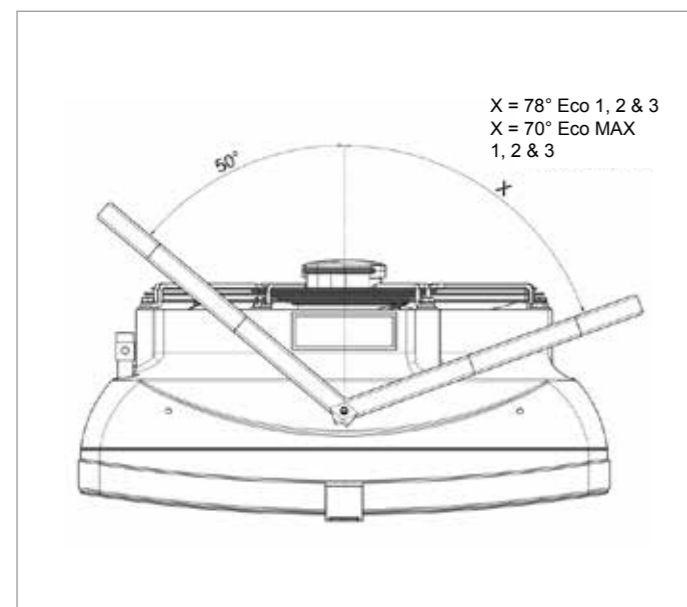

7. Automatic control - installation

A set of automatic control may be used (powered 230V) that consists of the following:

- COMFORT panel - including room thermostat and switch for regulation of 3 speeds of fan. One COMFORT panel may regulate up to 3 pcs of Solano Eco 1, 2 and 3 units or 2 pcs of Solano Eco MAX
- 2-way water valve with actuator; valve should be installed on a return stub of the heater
- INTELLIGENT electronic control panel with an automatic speed controller, weekly program and BMS communication. One INTELLIGENT panel may regulate up to 2 pcs of Solano Eco units or for single Solano Eco MAX
- Splitter MULTI 6 - control up to 6 pcs of Solano Eco, Solano Eco MAX units from one COMFORT or INTELLIGENT Panel

The system is ready to start once the connections between the thermostat and the valve actuator are done, 230V power is supplied to the thermostat and the fan's motor is powered by the revs controller.



COMFORT panel description

ON/OFF - turning ON/OFF a unit

I-II-III - switch for fan speed regulation

HEAT - thermostat sends signal for valve and actuator and fan, fan turns off when temperature in room is achieved, valve/actuator closes water supply.

FAN - function not active, unit will not operate when FAN switch is selected

COOL - thermostat sends signal only to fan and to the servo of the valve, fan begins operation starting from temperature which is set on thermostat (function used to air mixer Solano MIX or for room ventilation in summer season)

8. First start

Do all the connections (electrical, water and automatic control), check for tightness of all connections done by an installer and air-release/vent the device then start the device in the following sequence:

1. Switch on the mains,
2. Set requested speed of fan on revs controller,
3. Set requested temperature on thermostat,

The fan operates continuously irrespective of whether the heater's valve is opened or not.

9. Turning off

To switch the device off do the following:

1. Set minimum temperature on thermostat - after 7 seconds valve will be closed and heating switched off.
2. Set main switch to the "0" position (off); fan will be switched off and the thermostat will be off the power.

10. Operation

The engine and fan used in Solano Eco and Eco MAX units are maintenance-free devices but regular check-ups are advised, especially motor and bearing (fan's rotor should rotate freely, free from any axial and radial throws and undesired knocks/rattles).

NOTICE!

- In case of any metallic knocks, vibration or increase in sound level check if the fan mounting/fixing does not work loose contact the installer or Smith's Authorised Service

11. Maintenance

The heat exchanger requires systematical cleaning all with all dirt/impurities cleaned off. Before the start of the heating period the heat ex-changer is advised to be cleaned with compressed air directed to the air outlets; there is no need for dismantling of the device. Pay special attention when cleaning the exchanger's fin due to high possibility of damaging them. If fins are bent use a tool specifically designated to carry out such repairs. If the device has not been used for a longer period of time, unplug it before the next use.

The heat exchanger is not equipped with any frost protection device. The heat exchanger may be damaged if the room temperature goes below 0°C.

Anti-freeze liquid must be added to the water circulation/system. Anti-freeze liquid must be appropriate for the material the exchanger is made of (copper) as well as other elements of the hydraulic system. The liquid must be diluted with water according to the solution recommended by the anti-freeze manufacturer.

12. Technical data

Heater Eco 1

inlet/outlet water temperature		water 50/30 °C					water 60/40 °C					water 70/50 °C				
inlet air temperature °C		0	5	10	15	20	0	5	10	15	20	0	5	10	15	20
High speed - Air flow 3900 m³/h (speed 3)																
heat output	kW	8.7	7.1	5.4	3.6	1.7	12.4	10.8	9.3	7.7	6.1	16.0	14.4	12.9	11.3	9.7
outlet air temperature	°C	7.3	10.5	14.2	17.8	21.3	10.2	14.4	18.5	22.7	26.9	12.8	16.9	21.2	25.3	29.4
water flow	m³/h	0.4	0.3	0.2	0.2	0.1	0.5	0.5	0.4	0.3	0.3	0.7	0.6	0.6	0.5	0.4
pressure drop	kPa	2.8	1.9	1.2	0.6	0.2	4.8	3.8	2.9	2.1	1.4	7.1	5.9	4.8	3.8	2.9
Mid speed - Air flow 2500 m³/h (speed 2)																
heat output	kW	6.7	5.5	4.2	2.1	1.5	9.7	8.5	7.2	6.0	4.7	12.5	11.3	10.0	8.8	7.6
outlet air temperature	°C	8.8	11.6	15.0	17.6	21.8	12.4	16.3	20.2	24.1	28.0	15.6	19.5	23.3	27.2	31.1
water flow	m³/h	0.3	0.2	0.2	0.1	0.1	0.4	0.4	0.3	0.3	0.2	0.5	0.5	0.4	0.4	0.3
pressure drop	kPa	1.8	1.2	0.8	0.2	0.1	3.1	2.4	1.9	1.3	0.9	4.6	3.8	3.1	2.5	1.9
Low speed - Air flow 1850 m³/h (speed 1)																
heat output	kW	5.6	4.5	3.4	2.0	1.4	8.1	7.1	6.1	5.0	3.9	10.5	9.5	8.4	7.4	6.4
outlet air temperature	°C	9.9	12.4	15.5	18.2	22.3	14.0	17.8	21.5	25.1	28.6	17.7	21.4	25.1	28.7	32.3
water flow	m³/h	0.3	0.2	0.2	0.1	0.1	0.4	0.3	0.3	0.2	0.2	0.5	0.4	0.4	0.3	0.3
pressure drop	kPa	1.3	0.9	0.5	0.2	0.1	2.3	1.8	1.4	1.0	0.6	3.4	2.8	2.3	1.8	1.4

inlet/outlet water temperature		water 80/60 °C					water 90/70 °C					water 120/90 °C				
inlet air temperature °C		0	5	10	15	20	0	5	10	15	20	0	5	10	15	20
High speed - Air flow 3900 m³/h (speed 3)																
heat output	kW	21.1	19.4	17.6	15.9	14.2	23.0	21.4	19.7	17.9	16.1	37.9	35.9	33.9	31.9	29.9
outlet air temperature	°C	17.2	21.7	26.3	30.8	35.5	18.0	25.8	30.7	35.5	40.3	30.7	36.0	41.3	46.6	51.9
water flow	m³/h	0.8	0.8	0.7	0.6	0.6	0.8	0.8	0.7	0.7	0.6	0.9	0.8	0.8	0.7	0.7
pressure drop	kPa	9.7	8.4	7.1	5.9	4.8	9.7	8.7	7.7	6.8	5.9	9.4	8.5	7.7	6.9	6.1
Mid speed - Air flow 2500 m³/h (speed 2)																
heat output	kW	16.4	15.1	13.8	12.4	11.1	21.0	19.5	18.1	16.6	15.2	29.6	28.0	26.5	24.9	23.4
outlet air temperature	°C	20.9	25.2	29.4	33.7	38.0	25.6	30.1	34.6	39.0	43.6	37.4	42.3	47.3	52.2	57.3
water flow	m³/h	0.7	0.6	0.5	0.5	0.4	0.8	0.7	0.7	0.6	0.6	0.7	0.6	0.6	0.6	0.5
pressure drop	kPa	6.3	5.4	4.6	3.8	3.1	8.0	7.1	6.2	5.3	4.5	6.0	5.5	4.9	4.4	4.0
Low speed - Air flow 1850 m³/h (speed 1)																
heat output	kW	13.8	12.7	11.6	10.4	9.3	17.6	16.4	15.2	14.0	12.8	24.8	23.5	22.2	20.9	19.6
outlet air temperature	°C	23.6	27.7	31.8	35.8	39.8	29.0	33.2	37.5	41.8	45.9	42.3	47.0	51.8	56.4	61.2
water flow	m³/h	0.5	0.5	0.5	0.4	0.4	0.6	0.6	0.6	0.5	0.5	0.6	0.5	0.5	0.5	0.4
pressure drop	kPa	4.6	3.9	3.3	2.8	2.3	5.9	5.2	4.5	3.9	3.3	4.4	4.0	3.6	3.2	2.9

Heater Eco 2

inlet/outlet water temperature		water 50/30 °C					water 60/40 °C					water 70/50 °C				
inlet air temperature °C		0	5	10	15	20	0	5	10	15	20	0	5	10	15	20
High speed - Air flow 3350 m³/h (speed 3)																
heat output	kW	12.5	10.5	8.4	6.1	2.8	19.6	17.3	15.0	12.6	10.2	26.2	23.7	21.3	18.8	16.3
outlet air temperature	°C	10.7	14.3	16.9	19.5	21.9	16.6	19.0	21.2	23.5	25.8	22.1	24.6	27.1	29.5	32.0
water flow	m³/h	0.7	0.6	0.5	0.3	0.2	1.0	0.8	0.7	0.6	0.5	1.2	1.1	1.0	0.9	0.8
pressure drop	kPa	4.4	3.2	2.1	1.2	0.3	7.2	5.8	4.4	3.3	2.2	10.5	8.8	7.2	5.8	4.5
Mid speed - Air flow 2000 m³/h (speed 2)																
heat output	kW	9.1	7.6	6.0	4.2	2.4	14.2	12.6	10.9	9.2	7.4	19.0	17.2	15.5	13.7	11.9
outlet air temperature	°C	12.9	19.4	21.4	23.0	24.5	20.2	22.1	23.9	25.8	27.7	26.9	28.9	30.9	33.0	35.0
water flow	m³/h	0.5	0.4	0.3	0.2	0.1	0.7	0.6	0.5	0.4	0.4	0.9	0.8	0.7	0.6	0.5
pressure drop	kPa	2.5	1.8	1.2	0.6	0.2	4.1	3.3	2.5	1.9	1.3	5.9	4.9	4.1	3.3	2.6
Low speed - Air flow 1450 m³/h (speed 1)																
heat output	kW	7.3	6.1	4.8	2.9	2.1	11.5	10.2	8.8	7.4	6.0	15.3	13.9	12.5	11.1	9.6
outlet air temperature	°C	14.4	21.0	22.5	22.6	25.5	22.5	24.1	25.8	27.3	28.8	29.9	31.7	33.5	35.2	37.0
water flow	m³/h	0.4	0.3	0.3	0.2	0.1	0.6	0.5	0.4	0.4	0.3	0.7	0.6	0.6	0.5	0.4
pressure drop	kPa	1.7	1.2	0.8	0.3	0.2	2.8	2.2	1.7	1.3	0.9	4.0	3.4	2.8	2.2	1.8

inlet/outlet water temperature		water 80/60 °C					water 90/70 °C					water 120/90 °C				
inlet air temperature °C		0	5	10	15	20	0	5	10	15	20	0	5	10	15	20
High speed - Air flow 3350 m³/h (speed 3)																
heat output	kW	32.5	30.0	27.5	24.9	22.4	39.3	36.7	34.0	31.4	28.8	53.4	50.7	48.0	45.3	42.6
outlet air temperature	°C	27.2	29.7	32.2	34.8	37.3	32.4	35.0	37.6	40.2	42.7	45.0	47.6	50.4	53.1	55.9
water flow	m³/h	1.5	1.3	1.2	1.1	1.0	1.7	1.6	1.5	1.4	1.2	1.5	1.4	1.3	1.3	1.2
pressure drop	kPa	14.1	12.2	10.4	8.8	7.2	18.2	16.0	14.0	12.1	10.4	13.6	12.4	11.2	10.1	9.0
Mid speed - Air flow 2000 m³/h (speed 2)																
heat output	kW	23.5	21.7	19.9	18.1	16.3	28.4	26.5	24.6	22.7	20.9	38.6	36.7	34.8	32.8	30.9
outlet air temperature	°C	32.9	35.0	37.1	39.2	41.3	39.2	41.4	43.5	45.6	47.8	54.5	56.7	59.0	61.2	63.4
water flow	m³/h	1.1	1.0	0.9	0.8	0.7	1.2	1.1	1.1	1.0	0.9	1.1	1.0	1.0	0.9	0.9
pressure drop	kPa	7.9	6.8	5.8	4.9	4.1	10.1	8.9	7.8	6.8	5.8	7.6	6.9	6.3	5.7	5.1
Low speed - Air flow 1450 m³/h (speed 1)																
heat output	kW	19.0	17.5	16.1	14.6	13.2	22.9	21.4	19.9	18.4	16.9	31.2	29.6	28.1	26.5	25.0
outlet air temperature	°C	36.6	38.4	40.2	42.1	43.9	43.5	45.4	47.3	49.2	51.1	60.6	62.5	64.6	66.5	68.4
water flow	m³/h	0.8	0.8	0.7	0.7	0.6	1.0	0.9	0.9	0.8	0.7	0.9	0.8	0.8	0.7	0.7
pressure drop	kPa	5.4	4.7	4.0	3.4	2.8	6.9	6.1	5.3	4.6	4.0	5.2	4.7	4.3	3.9	3.5

12. Technical data

Heater Eco 3

inlet/outlet water temperature		water 50/30 °C					water 60/40 °C					water 70/50 °C				
inlet air temperature °C		0	5	10	15	20	0	5	10	15	20	0	5	10	15	20
High speed - Air flow 2950 m³/h (speed 3)																
heat output	kW	20.0	17.0	14.0	10.8	7.2	27.9	24.8	21.7	18.6	15.3	35.3	32.1	29.0	25.8	22.6
outlet air temperature	°C	20.1	21.5	22.8	24.0	24.9	27.2	28.8	30.2	31.6	33.0	34.2	35.8	37.3	38.7	40.2
water flow	m³/h	1.0	0.9	0.7	0.5	0.4	1.3	1.2	1.0	0.9	0.7	1.7	1.5	1.4	1.2	1.1
pressure drop	kPa	7.9	5.9	4.1	2.6	1.3	12.5	10.1	8.0	6.0	4.3	17.8	15.0	12.5	10.1	8.0
Mid speed - Air flow 1700 m³/h (speed 2)																
heat output	kW	13.5	11.5	9.4	7.2	3.9	18.7	16.7	14.6	12.6	10.4	23.6	21.5	19.5	17.4	15.3
outlet air temperature	°C	23.9	24.8	25.5	26.3	27.0	32.3	33.2	34.2	35.1	35.9	40.4	41.4	42.4	43.4	44.4
water flow	m³/h	0.7	0.6	0.5	0.4	0.2	0.9	0.8	0.7	0.6	0.5	1.1	1.0	0.9	0.8	0.7
pressure drop	kPa	3.9	2.9	2.0	1.3	0.4	6.1	5.0	3.9	3.0	2.1	8.6	7.3	6.1	5.0	3.9
Low speed - Air flow 1200 m³/h (speed 1)																
heat output	kW	10.4	8.8	7.2	5.4	3.4	14.4	12.9	11.3	9.7	8.0	18.1	16.6	15.0	13.4	11.8
outlet air temperature	°C	26.1	27.9	29.6	31.1	32.3	35.2	36.0	36.6	37.1	37.6	44.0	44.7	45.5	46.2	46.9
water flow	m³/h	0.5	0.4	0.4	0.3	0.2	0.7	0.6	0.5	0.5	0.4	0.9	0.8	0.7	0.6	0.6
pressure drop	kPa	2.4	1.8	1.3	0.8	0.3	3.8	3.1	2.5	1.9	1.3	5.4	4.6	3.8	3.1	2.5

inlet/outlet water temperature		water 80/60 °C					water 90/70 °C					water 120/90 °C				
inlet air temperature °C		0	5	10	15	20	0	5	10	15	20	0	5	10	15	20
High speed - Air flow 2950 m³/h (speed 3)																
heat output	kW	42.5	39.4	36.2	33.0	29.8	50.1	46.9	43.6	40.4	37.2	67.1	63.8	60.5	57.2	54.0
outlet air temperature	°C	41.0	42.6	44.1	45.7	47.2	47.9	49.5	51.0	52.6	54.1	63.5	65.0	66.5	68.0	69.5
water flow	m³/h	2.0	1.8	1.7	1.5	1.4	2.3	2.1	2.0	1.9	1.7	2.0	1.9	1.8	1.7	1.6
pressure drop	kPa	23.6	20.5	17.6	14.9	12.4	29.9	26.5	23.3	20.3	17.5	22.5	20.6	18.7	16.9	15.2
Mid speed - Air flow 1700 m³/h (speed 2)																
heat output	kW	28.3	26.3	24.2	22.1	20.0	33.3	31.2	29.1	27.0	24.9	44.7	42.5	40.4	38.2	36.1
outlet air temperature	°C	48.3	49.3	50.4	51.4	52.4	56.2	57.3	58.4	59.4	60.5	74.6	75.6	76.7	77.7	78.7
water flow	m³/h	1.3	1.2	1.1	1.0	0.9	1.5	1.4	1.3	1.2	1.1	1.4	1.3	1.2	1.2	1.1
pressure drop	kPa	11.3	9.9	8.5	7.2	6.1	14.3	12.7	11.2	9.8	8.5	10.8	9.9	9.0	8.2	7.4
Low speed - Air flow 1200 m³/h (speed 1)																
heat output	kW	21.7	20.2	18.6	17.0	15.4	25.5	23.9	22.3	20.7	19.1	34.2	32.6	31.0	29.4	27.8
outlet air temperature	°C	54.2	53.3	54.0	54.8	55.5	60.4	61.1	61.9	62.7	63.4	79.6	80.4	81.2	81.9	82.7
water flow	m³/h	1.0	0.9	0.9	0.8	0.7	1.2	1.1	1.0	0.9	0.9	1.0	1.0	0.9	0.9	0.8
pressure drop	kPa	7.0	6.1	5.3	4.5	3.8	8.8	7.9	6.9	6.1	5.3	6.7	6.1	5.6	5.1	4.6

Heater Eco MAX 1

inlet/outlet water temperature		water 50/30 °C					water 60/40 °C					water 70/50 °C				
inlet air temperature °C		0	5	10	15	20	0	5	10	15	20	0	5	10	15	20
High speed - Air flow 5700 m³/h (speed 3)																
heat output	kW	24.5	20.5	16.5	12.3	7.5	32.2	28.3	24.5	20.6	16.7	39.7	35.9	32.0	28.3	24.5
outlet air temperature	°C	13.7	16.8	19.8	22.7	25.0	18.0	21.1	24.2	27.3	30.2	22.3	25.5	28.6	31.7	34.8
water flow	m³/h	0.8	0.6	0.5	0.4	0.2	1.0	0.9	0.8	0.7	0.5	1.3	1.2	1.0	0.9	0.8
pressure drop	kPa	3.5	2.5	1.7	0.9	0.3	5.8	4.6	3.5	2.6	1.8	8.4	7.0	5.7	4.5	3.5
Mid speed - Air flow 3900 m³/h (speed 2)																
heat output	kW	19.6	16.4	13.1	9.7	4.4	25.7	22.6	19.5	16.5	13.4	31.7	28.6	25.6	22.6	19.6
outlet air temperature	°C	15.9	18.6	21.3	23.7	24.4	20.9	23.7	26.6	29.2	31.8	25.9	28.8	31.6	34.5	37.2
water flow	m³/h	0.9	0.8	0.6	0.5	0.2	1.3	1.1	1.0	0.8	0.7	1.6	1.4	1.3	1.1	1.0
pressure drop	kPa	5.1	3.7	2.5	1.4	0.4	8.5	6.7	5.2	3.8	2.6	12.3	10.2	8.3	6.7	5.1
Low speed - Air flow 2800 m³/h (speed 1)																
heat output	kW	15.9	13.3	10.6	7.7	4.0	20.9	18.4	15.9	13.4	10.8	25.6	23.2	20.7	18.3	15.9
outlet air temperature	°C	18.0	20.4	22.7	24.5	25.4	23.6	26.2	28.7	31.0	33.3	29.2	31.9	34.5	37.0	39.4
water flow	m³/h	0.8	0.6	0.5	0.4	0.2	1.0	0.9	0.8	0.7	0.5	1.3	1.2	1.0	0.9	0.8
pressure drop	kPa	3.5	2.5	1.7	0.9	0.3	5.8	4.6	3.5	2.6	1.8	8.4	7.0	5.7	4.5	3.5

inlet/outlet water temperature		water 80/60 °C					water 90/70 °C					water 120/90 °C				
inlet air temperature °C		0	5	10	15	20	0	5	10	15	20	0	5	10	15	20
High speed - Air flow 5700 m³/h (speed 3)																
heat output	kW	47.5	43.6	39.8	36.0	32.2	55.0	51.1	47.2	43.4	39.6	72.4	68.5	64.5	60.6	56.8
outlet air temperature	°C	26.0	29.2	32.3	35.4	38.4	30.1	33.3	36.4	39.5	42.6	39.3	42.6	45.9	49.1	52.2
water flow	m³/h	1.5	1.4	1.3	1.2	1.0	1.8	1.7	1.5	1.4	1.3	1.6	1.5	1.4	1.3	1.3
pressure drop	kPa	11.3	9.7	8.2	6.8	5.6	14.5	12.7	11.0	9.4	8.0	10.9	9.8	8.8	7.9	7.0
Mid speed - Air flow 3900 m³/h (speed 2)																
heat output	kW	37.8	34.7	31.7	28.7	25.7	43.7	40.6	37.6	34.5	31.5	57.4	54.3	51.1	48.0	45.0
outlet air temperature	°C	30.2	33.1	36.0	38.7	41.5	34.9	37.8	40.7	43.5	46.3	45.8	48.8	51.9	54.8	57.7
water flow	m³/h	1.9	1.8	1.6	1.4	1.3	2.2	2.1	1.9	1.8	1.6	2.0	1.9	1.8	1.7	1.5
pressure drop	kPa	16.6	14.2	12.0	10.0	8.2	21.4	18.7	16.2	13.9	11.8	16.1	14.5	13.0	11.6	10.3
Low speed - Air flow 2800 m³/h (speed 1)																
heat output	kW	30.6	28.1	25.6	23.2	20.8	35.3	32.8	30.4	27.9	25.5	46.5	43.9	41.3	38.9	36.4
outlet air temperature	°C	34.0	36.8	39.3	41.8	44.2	39.3	42.0	44.6	47.1	49.7	51.5	54.5	57.2	59.9	62.5
water flow	m³/h	1.5	1.4	1.3	1.2	1.0	1.8	1.7	1.5	1.4	1.3	1.6	1.5	1.4	1.3	1.3
pressure drop	kPa	11.3	9.7	8.2	6.8	5.6	14.5	12.7	11.0	9.4	8.0	10.9	9.8	8.8	7.9	7.0

12. Technical data

Heater Eco MAX 2

inlet/outlet water temperature		water 50/30 °C					water 60/40 °C					water 70/50 °C				
inlet air temperature °C		0	5	10	15	20	0	5	10	15	20	0	5	10	15	20
High speed - Air flow 5600 m³/h (speed 3)																
heat output	kW	31.9	27.0	22.2	17.2	11.8	41.6	36.8	32.0	27.3	22.5	53.0	48.0	43.1	38.2	33.3
outlet air temperature	°C	20.9	24.8	28.4	31.9	35.1	27.3	31.4	35.5	39.3	43.2	35.0	39.3	43.3	47.4	51.3
water flow	m³/h	1.4	1.2	0.9	0.7	0.5	1.7	1.5	1.3	1.1	0.9	2.2	2.0	1.8	1.6	1.4
pressure drop	kPa	10.5	7.8	5.4	3.4	1.7	15.9	12.7	9.9	7.4	5.2	23.7	19.8	16.3	13.1	10.2
Mid speed - Air flow 3800 m³/h (speed 2)																
heat output	kW	25.3	21.4	17.5	13.5	9.0	32.9	29.1	25.3	21.6	17.8	41.9	37.9	34.0	30.2	26.4
outlet air temperature	°C	24.2	27.6	30.8	33.8	36.0	31.6	35.3	38.9	42.3	45.6	40.4	44.3	47.9	51.5	55.0
water flow	m³/h	1.1	0.9	0.7	0.6	0.4	1.4	1.2	1.1	0.9	0.7	1.7	1.6	1.4	1.3	1.1
pressure drop	kPa	6.9	5.1	3.6	2.2	1.1	10.4	8.3	6.5	4.8	3.4	15.4	12.9	10.6	8.5	6.7
Low speed - Air flow 2750 m³/h (speed 1)																
heat output	kW	20.1	17.3	14.1	10.8	6.1	26.5	23.5	20.4	17.4	14.4	33.7	30.5	27.4	24.3	21.2
outlet air temperature	°C	27.2	30.1	32.8	35.2	35.5	35.5	38.8	41.9	45.1	47.8	45.3	48.8	52.1	55.1	58.2
water flow	m³/h	0.9	0.7	0.6	0.5	0.3	1.1	1.0	0.9	0.7	0.6	1.4	1.3	1.1	1.0	0.9
pressure drop	kPa	4.7	3.5	2.4	1.5	0.5	7.0	5.6	4.4	3.3	2.3	10.4	8.7	7.2	5.8	4.5

inlet/outlet water temperature		water 80/60 °C					water 90/70 °C					water 120/90 °C				
inlet air temperature °C		0	5	10	15	20	0	5	10	15	20	0	5	10	15	20
High speed - Air flow 5600 m³/h (speed 3)																
heat output	kW	61.9	57.0	52.1	47.3	42.5	74.2	69.0	63.9	58.9	53.9	96.6	91.4	86.3	81.2	76.2
outlet air temperature	°C	41.0	45.5	49.9	54.1	58.2	49.1	53.5	57.9	62.2	66.4	63.2	68.1	72.6	77.2	81.8
water flow	m³/h	2.6	2.4	2.2	2.0	1.8	3.1	2.8	2.6	2.4	2.2	2.6	2.5	2.4	2.2	2.1
pressure drop	kPa	30.1	25.9	22.0	18.4	15.2	40.3	35.3	30.7	26.5	22.5	28.9	26.1	23.5	21.0	18.7
Mid speed - Air flow 3800 m³/h (speed 2)																
heat output	kW	48.9	45.0	41.1	37.3	33.5	58.4	54.3	50.3	46.4	42.4	76.2	72.1	68.0	64.0	60.0
outlet air temperature	°C	47.4	51.5	55.4	59.2	62.9	56.5	60.6	64.6	68.4	72.1	72.9	77.4	81.7	85.8	89.8
water flow	m³/h	2.0	1.9	1.7	1.5	1.4	2.4	2.2	2.1	1.9	1.8	2.1	2.0	1.9	1.7	1.6
pressure drop	kPa	19.6	16.8	14.3	12.0	9.9	26.1	22.9	19.9	17.1	14.6	18.7	16.9	15.2	13.6	12.1
Low speed - Air flow 2750 m³/h (speed 1)																
heat output	kW	39.3	36.2	33.1	30.0	27.0	46.9	43.7	40.4	37.2	34.1	61.3	58.0	54.7	51.4	48.2
outlet air temperature	°C	53.2	56.8	60.3	63.7	67.1	63.1	66.8	70.5	73.9	77.3	81.7	85.8	89.7	93.5	97.1
water flow	m³/h	1.6	1.5	1.4	1.2	1.1	1.9	1.8	1.7	1.5	1.4	1.7	1.6	1.5	1.4	1.3
pressure drop	kPa	13.2	11.3	9.6	8.1	6.7	17.5	15.3	13.3	11.5	9.8	12.6	11.4	10.2	9.2	8.1

Heater Eco MAX 3

inlet/outlet water temperature		water 50/30 °C					water 60/40 °C					water 70/50 °C				
inlet air temperature °C		0	5	10	15	20	0	5	10	15	20	0	5	10	15	20
High speed - Air flow 5100 m³/h (speed 3)																
heat output	kW	42.1	35.7	29.3	22.9	16.0	54.1	47.9	41.7	35.5	29.3	68.3	61.9	55.5	49.2	42.9
outlet air temperature	°C	26.9	29.8	32.6	35.3	37.6	34.7	38.1	41.2	44.3	47.1	44.1	47.5	50.6	53.8	56.8
water flow	m³/h	1.6	1.4	1.1	0.9	0.6	2.1	1.8	1.6	1.4	1.1	2.6	2.4	2.1	1.9	1.6
pressure drop	kPa	14.3	10.7	7.5	4.8	2.5	21.6	17.3	13.5	10.1	7.2	32.1	26.8	22.0	17.7	13.8
Mid speed - Air flow 3400 m³/h (speed 2)																
heat output	kW	32.3	27.4	22.5	17.5	12.1	41.4	36.7	32.0	27.3	22.5	52.2	47.2	42.4	37.6	32.9
outlet air temperature	°C	30.9	33.3	35.6	37.6	39.0	39.8	42.7	45.4	47.8	50.2	50.5	53.4	56.1	58.7	61.1
water flow	m³/h	1.2	1.1	0.9	0.7	0.5	1.6	1.4	1.2	1.0	0.9	2.0	1.8	1.6	1.4	1.3
pressure drop	kPa	8.9	6.6	4.6	2.9	1.5	13.3	10.7	8.3	6.3	4.4	19.6	16.4	13.5	10.9	8.5
Low speed - Air flow 2400 m³/h (speed 1)																
heat output	kW	25.3	21.5	17.6	13.6	9.0	32.4	28.7	25.0	21.4	17.7	40.7	36.9	33.1	29.4	25.7
outlet air temperature	°C	34.4	36.4	38.1	39.4	39.7	44.4	46.7	49.0	51.0	52.8	56.1	58.4	60.7	62.9	64.9
water flow	m³/h	1.0	0.8	0.7	0.5	0.3	1.2	1.1	1.0	0.8	0.7	1.6	1.4	1.3	1.1	1.0
pressure drop	kPa	5.7	4.2	3.0	1.9	0.9	8.6	6.9	5.4	4.0	2.9	12.5	10.5	8.6	6.9	5.4

inlet/outlet water temperature		water 80/60 °C					water 90/70 °C					water 120/90 °C				
inlet air temperature °C		0	5	10	15	20	0	5	10	15	20	0	5	10	15	20
High speed - Air flow 5100 m³/h (speed 3)																
heat output	kW	79.5	73.1	66.8	60.6	54.4	93.9	87.3	80.8	74.4	68.0	121.6	115.0	108.4	101.9	95.5
outlet air temperature	°C	51.0	54.5	57.9	61.2	64.5	60.1	63.6	67.0	70.4	73.5	78.0	81.8	85.5	89.2	92.6
water flow	m³/h	3.0	2.8	2.6	2.3	2.1	3.6	3.4	3.1	2.9	2.6	3.1	3.0	2.8	2.6	2.5
pressure drop	kPa	40.8	35.1	29.8	24.9	20.5	54.3	47.5	41.3	35.5	30.2	39.2	35.4	31.8	28.4	25.2
Mid speed - Air flow 3400 m³/h (speed 2)																
heat output	kW	60.6	55.8	51.0	46.2	41.5	71.5	66.4	61.5	56.6	51.7	92.8	87.7	82.6	77.7	72.8
outlet air temperature	°C	58.3	61.3	64.3	67.0	69.8	68.5	71.6	74.5	77.3	80.0	89.1	92.5	95.8	98.9	101.9
water flow	m³/h	2.3	2.1	1.9	1.8	1.6	2.7	2.6	2.4	2.2	2.0	2.4	2.3	2.1	2.0	1.9
pressure drop	kPa	25.0	21.4	18.2	15.3	12.6	33.0	28.9	25.1	21.6	18.3	23.9	21.6	19.4	17.3	15.4
Low speed - Air flow 2400 m³/h (speed 1)																
heat output	kW	47.3	43.5	39.7	36.1	32.4	55.6	51.6	47.8	44.0	40.2	72.3	68.3	64.4	60.5	56.7
outlet air temperature	°C	64.6	67.3	69.8	72.2	74.4	75.8	78.4	81.0	83.4	85.6	98.8	101.8	104.7	107.3	109.9
water flow	m³/h	1.8	1.7	1.5	1.4	1.2	2.1	2.0	1.8	1.7	1.5	1.9	1.8	1.7	1.6	1.5
pressure drop	kPa	15.9	13.6	11.6	9.7	8.0	20.9	18.3	15.9	13.6	11.6	15.2	13.7	12.3	11.0	9.7

13. Electrical connection diagrams

13.1. Connecting Solano units with no automatic control

* The unit set does not consist of: a master switch, a fuse, a feeding cable

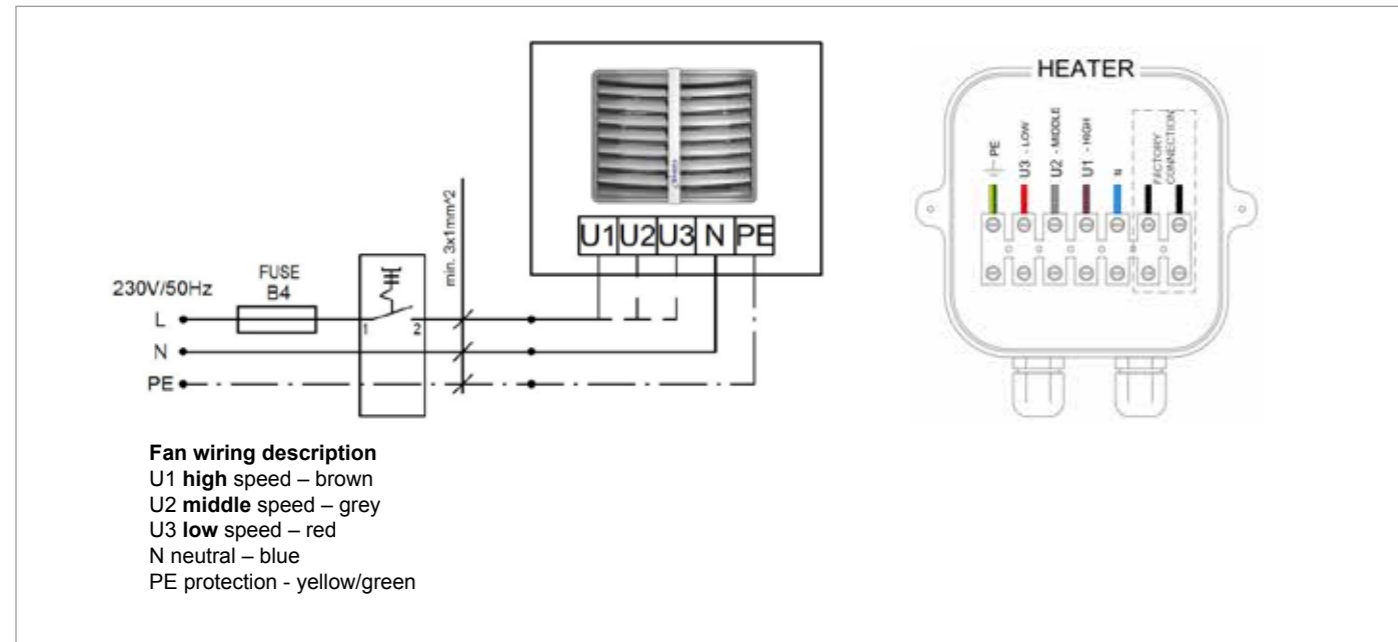

13.2. Connecting several Solano units with COMFORT panel, valves and actuators

One COMFORT panel may regulate up to:

- 3 pcs of Solano Eco 1, 2 or 3
- 2 pcs of Solano MAX

* The unit set does not consist of: a master switch, a fuse, a feeding cable

HEAT - thermostat sends signal for valve/actuator and fan, fan turns off when temperature in room is achieved, valve/actuator closes water supply.

FAN - function not active, unit will not operate when FAN switch is selected

COOL - thermostat sends signal only to fan and the servo of the valve, fan begins operation starting from temperature which is set on thermostat (function used to air mixer Solano MIX or for room ventilation in summer season)

Attention! You can use additional jumper on the contacts 4-5 of COMFORT Panel, in this case you may only use function of changing speed of fan I-II-III and ON/OFF. The thermostat and switches HEAT/FAN/COOL remain not active.

Additional jumper on terminals 4-5 might be applied when for ex different (supplied by user) thermostat is used to control the system.

In that case:

- motor would be working on set speed
- thermostat open/close the servo of the valve depending on set temperature

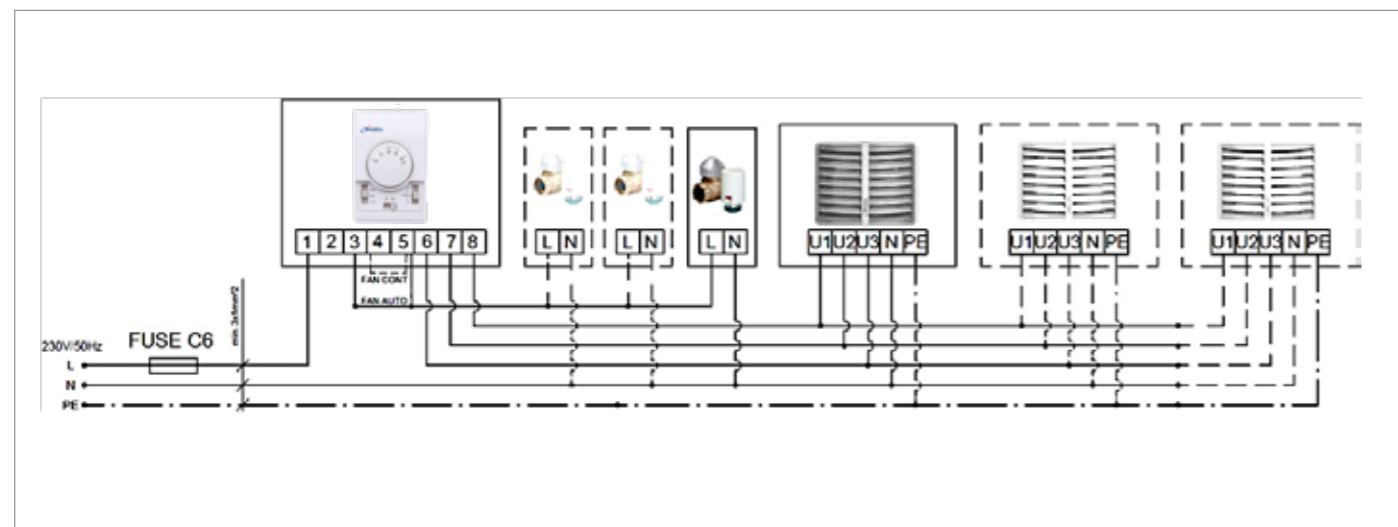

13.3. Connecting Solano units with panel INTELLIGENT.

Panel Intelligent controls actuators/valves and automatically regulates fans' speed depending on the required room temperature. Fans speed changes automatically for lower rate, when temperature in a room gets closer to desired one.

Additional functions - weekly thermostat, availability of BMS communication signals

Possibility to connect outside temperature sensor NTC, supplied with cable length 5 m, max cable length 20 m.

One INTELLIGENT panel may regulate:

- up to 2 pcs of Solano Eco.
- For Solano Eco MAX only 1 pcs

* The unit set does not consist of: a master switch, a fuse, a feeding cable

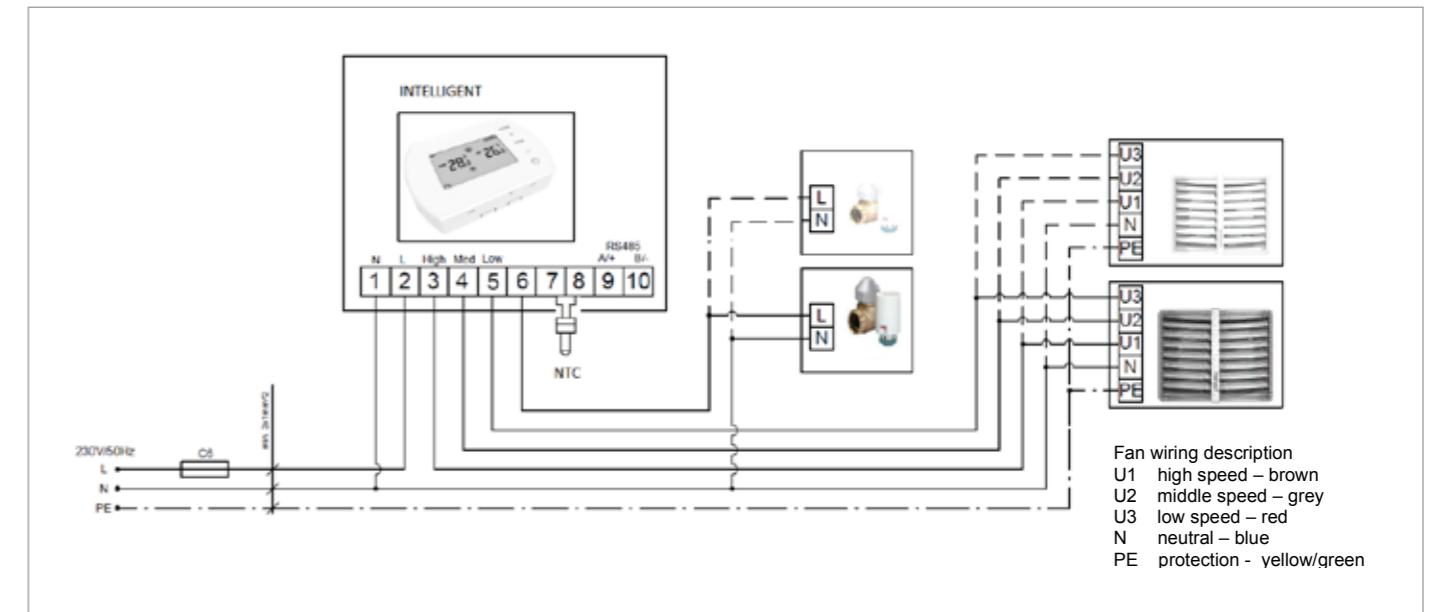

13.4. Splitter MULTI 6 - control up to 6 pieces of Solano Eco/Solano Eco MAX from one COMFORT or INTELLIGENT Panel

MULTI 6 Splitter allows to connect and control more fan heaters (up to 6 pcs.) and valves with actuators (up to 6 pcs.). Control of fans and valves is done using COMFORT or INTELLIGENT panel.

To connect more than 6 fans and valves, it is possible to connect Splitter MULTI 6 with each other (maximum extension of up to 10 MULTI 6 splitters). In such case, in the first Splitter MULTI 6 there should be connector DS-N left open, in other Splitters MULTI 6 (2..10) connector DS-N must be closed.

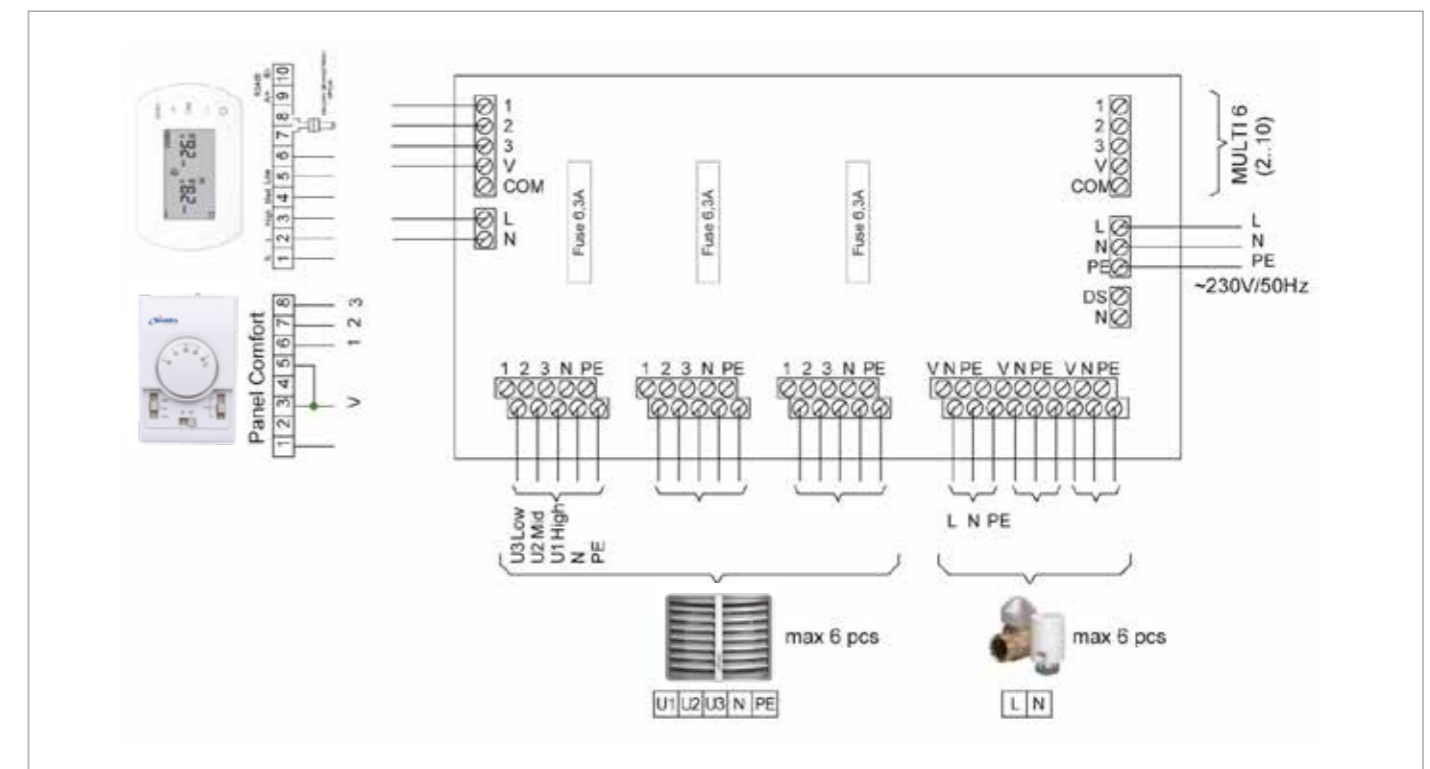

14. Panel intelligent - programmable controller manual

Panel Intelligent controls actuators/valves and automatically regulates fan's speed depending on the required room temperature. The lower temperature in the room the higher air output is set. Fans speed changes automatically for lower rate, when temperature in a room gets closer to desired one.



Functions

Panel INTELLIGENT is designed for the Smith's products

- Weekly thermostat (5/1/1 days)
- Automatic or manual 3-step fan speed adjustment.
- Control room temperature (by opening/closing the valve, or by adjusting air volume automatically).
- Antifreeze mode- protection against dropping room temperature below critical level +5/-15°C.
- Possibility to connect external NTC temperature sensor.
- BMS communication by MODBUS protocol

Panel description

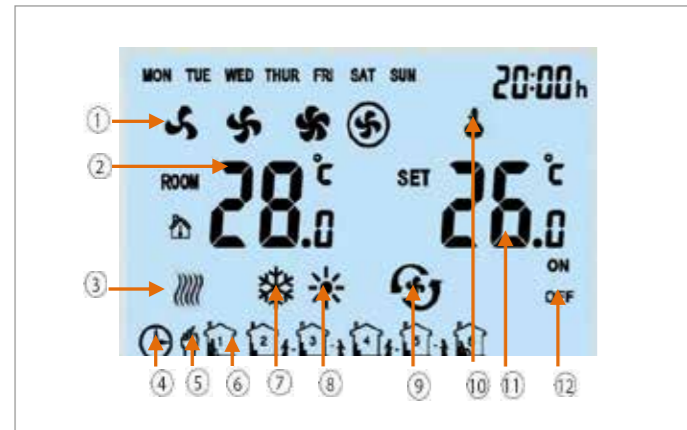

1. Fan Speed: LOW, MED, HI and AUTO
2. ROOM TEMP or NTC EXTERNAL SENSOR TEMP (measured temperature)
3. Anti-freeze indication
4. Automatic programmable mode
5. Manual mode
6. 6 Time Zones for each day
7. Cooling mode
8. Heating mode
9. Ventilation mode



10. Buttons lock
11. SET TEMP. (desired room temperature)
12. ON/OFF status time zones
13. MODE
Press shortly to select manual or automatic mode
Press and hold for 3s and select cooling, heating or ventilation mode
14. FAN
Press shortly and select fan speed: Low, Med, High or Auto
15. ON/OFF INTELLIGENT Panel

Technical parameters

1	Power supply	230VAC/50Hz
2	Temperature setting range	5°C 40°C
3	Temperature working range	-10°C 60°C
4	IP class	20
5	Temperature sensor	Internal/external NTC (optional)

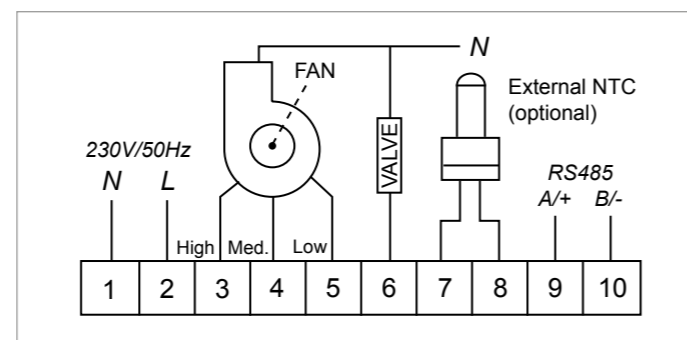

WARNING!

RISK OF ELECTRICAL SHOCK. Disconnect power supply before making any electrical connections. Contact with components carrying hazardous voltage can cause electrical shock and may result in severe personal injury

Dimensions

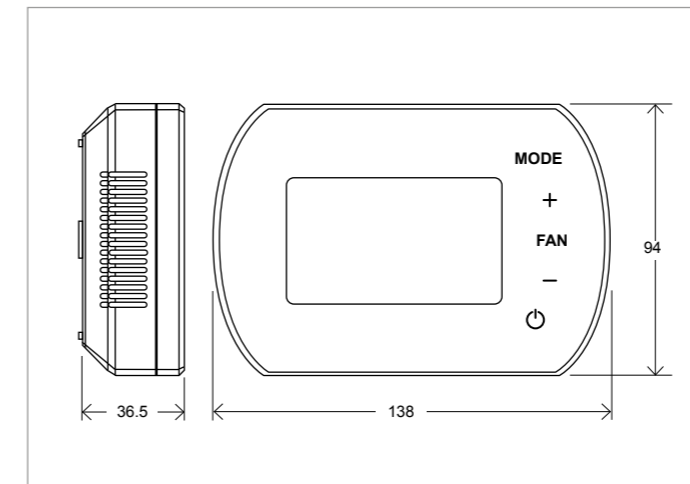

Setting menu

When Panel Intelligent is switched off, press and hold MODE for 5 seconds

To change option use MODE button

To change value use +/- buttons.

Setting menu	Option	Value
1	Temperature calibration	-9°C ~ +9°C
2	Fan status	C1: Thermostatic mode C2: Continuous mode
3	Temperature sensor	0: Internal Sensor 1: External Sensor NTC (optional)
4	Antifreeze	0: Off 1: On
5	Antifreeze range	+5°C ~ +10°C
6	BMS speed	0-2400 / 1-9600 / 2-19200
7	Modbus ID	1~247 (01~F7)

Button lock/unlock

To LOCK buttons press and hold + and then - and hold both of them for 5 seconds

To UNLOCK buttons press and hold + and then - and hold both of them for 5 seconds.

Press MODE

Change on manual mode or automatic mode

Hold MODE for 5 seconds

Change to cool mode heating mode ventilation

Press FAN

Change the fan speed low medium high automatic

Hold FAN for 5 seconds

Manual calendar programming Monday – Friday, Saturday, Sunday 6 settings per day

BMS Functions

- Setting/Reading work parameters Work/Stop conditions
- Weekly program
- Temperature
- Fan speed
- Heating, ventilation, cool mode Antifreeze mode

No.	Setting	Parameters
1	Working Mode	RS485 Semi-duplex; PC or main controller is master; thermostat is slave
2	Interface	A(+),B(-), 2 wires
3	Baud Rate	0-2400 / 1-9600 / 2-19200
4	Byte	9 bits in total: 8 data bit + 1 stop bit
5	Modbus	RTU Mode
6	Transmission	RTU (Remote Terminal Unit) format (please refer to MODBUS instruction)
7	Thermostat address	1-247: (0 is broadcast address and stand for all thermostat without response)



Happy to help

Smith's Environmental Products Ltd is one of the leading manufacturers of heating and cooling products in the UK. We are committed to achieving the highest standards and our faith is supported by a free parts and labour guarantee with every product (see our website for more information). Our customer service is second to none and we are happy to offer any help and guidance that you might need.

Stockists

All products are available nationally from Builders' Merchants, Plumbers' Merchants, Heating Equipment Distributors and Kitchen Equipment Distributors. In the event of difficulty, please contact us or visit our website SmithsEP.co.uk for details of your nearest stockist.

Information and advice

Full technical specifications and list prices is available to download from our website or in hard copy from our office. Also available on our website are price lists, individual product data sheets, installation & user guides, where to buy, who to contact and a media centre.

Alternatively contact our office 9.00am to 5.00pm Monday to Friday.

As part our commitment to continuous improvement Smith's Environmental Products may change the specifications of its products without prior notification or public announcement. All descriptions, illustrations, drawings and specifications in this publication present only general particulars and shall not form part of any contract. All dimensions are in mm unless otherwise stated. Please visit the website for the most up to date information.

**To view the full product information
download the datasheet at:
www.SmithsEP.co.uk**

For product information, customer services or sales support call us on **+44 (0) 1245 324900**

For the Republic of Ireland, contact MT Agencies on 01 864 3363

**Sales: sales@SmithsEP.co.uk
General information: info@SmithsEP.co.uk**

Smith's Environmental Products Ltd
Blackall Industrial Estate, South Woodham Ferrers,
Chelmsford, Essex CM3 5UW

SmithsEP.co.uk

[@SmithsEP_UK](https://twitter.com/SmithsEP_UK)

[#ThinkSmiths](https://www.facebook.com/ThinkSmiths)

Issue 002 | November 2022