

Joining Strip

These are used to cover joints between two abutting Sureline™ covers.

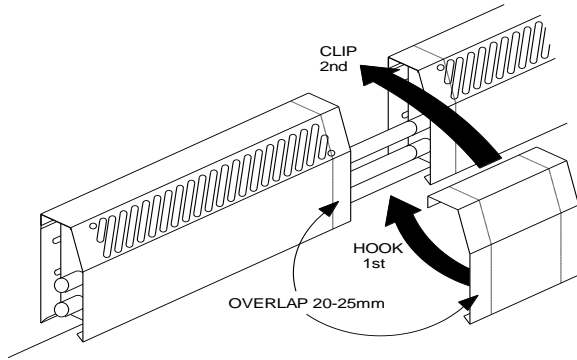

The joining strip is a single piece with a tab at the top and a snap tab at the bottom. To install, place the lower snap tab under the front cover, lift up and snap the top edge between the wall and the back of the Sureline™ covers. Once installation is complete the joining strip should fit snugly and the seams formed by the joining cover should be smooth and uninterrupted.



Products with the Recycling symbol cannot be disposed as household waste. Materials should be recycled at a facility capable of handling these products and their waste by products. Contact your local authority for details in locating a recycling facility nearest to you. Proper recycling and waste disposal will help conserve resources whilst preventing detrimental effects on our health and the environment.



Smith's Environmental Products Ltd

Blackall Industrial Estate, South Woodham Ferrers, Chelmsford, Essex, CM3 5UW
Tel: 01245 324900 Fax: 01245 324422

Sales: sales@SmithsEP.co.uk General Information E-mail: info@SmithsEP.co.uk Web: www.SmithsEP.co.uk

For Ireland, contact MT Agencies (Ireland) Ltd on Tel: 00353 1 844 3212

As part of the policy of continuous product improvement,
Smith's Environmental Products Ltd reserves the right to alter specification without prior notice.



INSTALLATION GUIDE

SURELINE™

INSTALLATION GUIDE

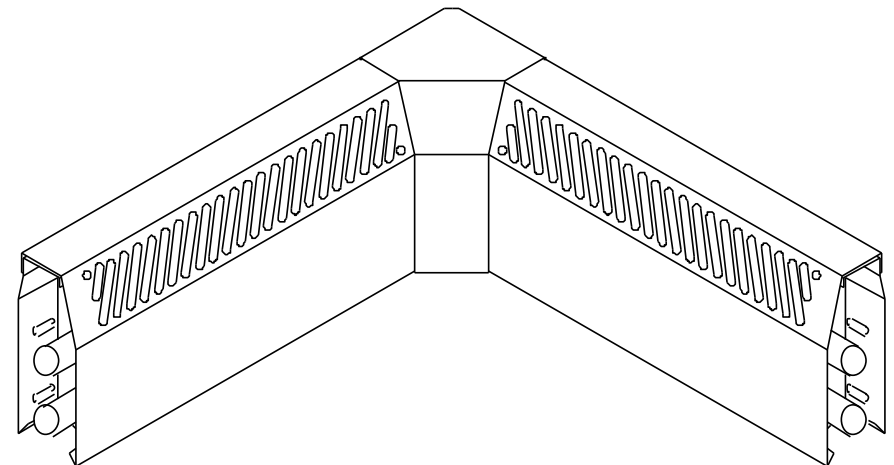

IMPORTANT

To prevent transit damage Sureline™ has been assembled. To prepare the components for installation, first slide the casing carefully off the back plate then slide the element off the back plate.

WARNING - THIS ELEMENT MAY CONTAIN SHARP EDGES AND SHOULD BE HANDLED WITH CARE TO PREVENT INJURY AND DAMAGE TO ELEMENT FINNS.

Where small children may have access to the underside of the completed installation we recommend fitment of the Child Safety Guard. Contact us on 01245 324900 for further information

Introduction

Sureline™ is designed to fit directly against perimeter walls to provide a consistent flow of warm air around the room. Sureline™ is supplied complete with wall fixing back plate, heating element, front cover and joining strip. Internal and external angles, valve cover boxes and child safety grilles in 0.5Mtr and 1.0Mtr lengths are available as accessories. Element only and casing only are also available to order.

Preparation

Ensure the walls are flat, sound and capable of safely supporting the product. A minimum **AIR GAP of 50mm** is required between the underside of the back plate and the finished floor surface at all times. Failure to comply with this requirement will significantly reduce the heat output.

Back plate

Fix the back plate to the wall ensuring it is level. Repeat for each length of back plate. Always allow a 150mm gap from the return walls to fix the internal or external corners. When using a centre valve cover allow a 125mm gap between each section of back plate.

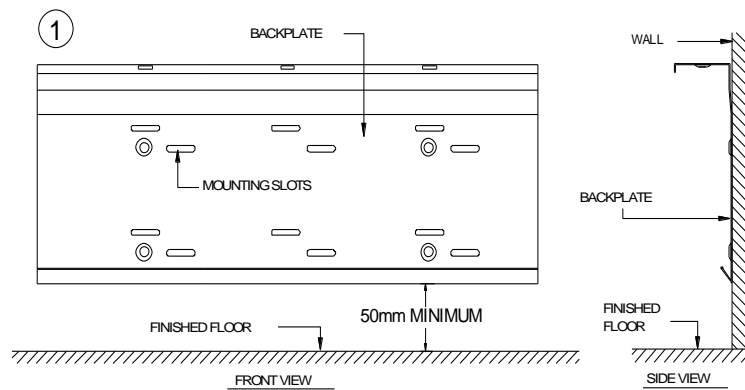

Casing only.

Casing only is used to complete a run of Sureline™ from wall to wall where the required heating output has been achieved and a dummy panel is required to ensure the installation looks uniform. Cut the back plate and front cover to the required length.

The back plate is installed first so that it is parallel and level with the back plate of the other lengths. The front cover and joining strip are then installed in the same manner as described for the standard installation.

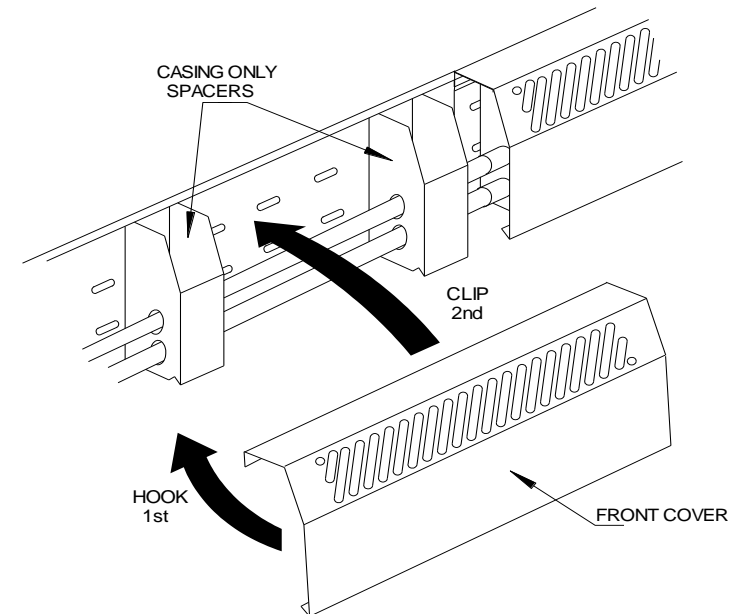

Child Safety Guard

Where small children may have access to the underside of the completed installation we recommend fitment of the Child Safety Guard. This comes in 0.5Mtr and 1.0 Mtr lengths and fits directly underneath the heat exchanger and clips into position between the lip on the back plate and the front casing.

Room Temperature Control

The Sureline™ valve box / end cap kits incorporate a facility to accept a 22mm Thermostatic Radiator Valve. Simply remove the knock out plate and the tail of the TRV body can be connected to the pipe work by means of a 22mm x 3/4" female BSP adaptor. Care must be taken not to distort the 22mm pipe and to ensure the flow direction and valve location conforms to the recommendations of the TRV manufacturer.

Sureline™ can also be controlled via a remote wall mounted room thermostat and a single port motorised valve.

Valve box / end cap kit (right and left hand)

These are used to finish the beginning and the end of the Sureline™ installation run. They allow supply and return pipes and valves to be fitted and allow the piping to enter the unit from the bottom.

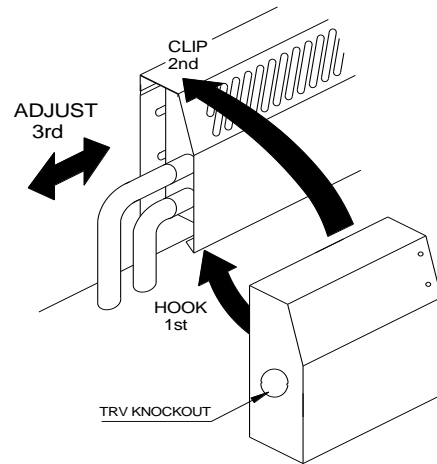

The Sureline™ Valve box / end cap kits are a single piece with tabs at the top and tab clips at the bottom. To install, place the lower snap tab under the front cover, lift up and snap the top edge between the wall and the back of the Sureline™ covers. Once installation is complete the joining strip should fit snugly and the seams formed by the joining cover should be smooth and uninterrupted.

Heating Element

Locate the lower rear of the element into the lower anchor lug on the bottom of the back plate and carefully pivot the element towards the back plate. Carefully snap the element into the upper anchor lug on the top of the back plate. The element is now ready for connecting to the flow and return pipe work.

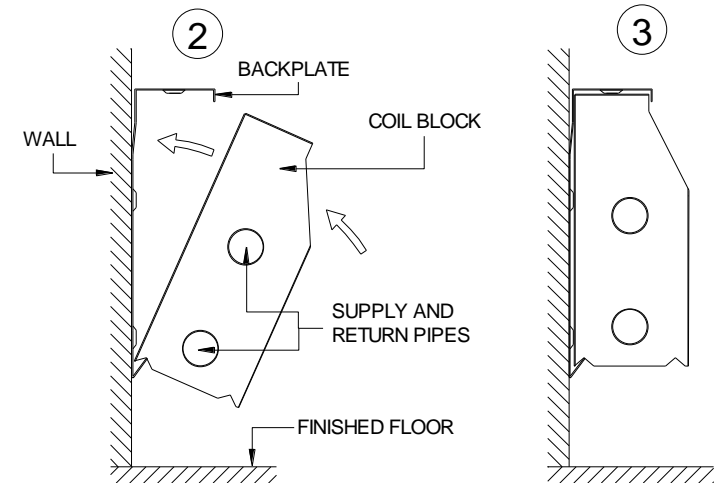

Pipe Work

The element is fitted with 22mm flow and return copper pipes. It is also acceptable to use both pipes as flow connections and provide a separate return run remotely from the casing. An expansion joint must be provided on any straight continuous runs longer than eight metres.

Commissioning

Check for any leaks and ensure adequate flow is providing the required water temperature for maximum output. It may be necessary to balance the system to achieve the best flow or water temperature.

Front casing Refer to drawings overleaf

Locate the lower locating lug of the front casing under the front lower anchor lug of the element. Pivot the casing carefully upwards towards the rear of the top of the back plate and snap into position. Repeat the above procedure when fitting the joining strips; valve boxes/end cap kits and internal or external corners where applicable.

90° & 135° internal corners

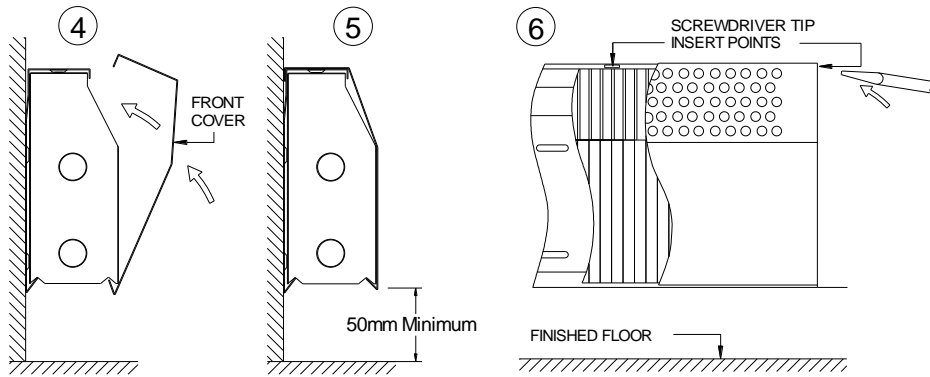

To remove the front casing, carefully ease a flat bladed screwdriver between the top of the front cover and the element. Gently lever the top of the case out of the back plate and reverse the fixing procedure.

90° & 135° internal corners & 90° & 135° external corners

The internal corners are a single piece with tabs at the top and tab clips at the bottom. To install, please ensure that the back plate is fixed to the two opposing wall surfaces with a maximum gap in from the corner of no more than 75mm. Place the bottom tab clip under the adjacent covers. Then angle the inside corner up so that the top tabs snaps in between the wall and the covers of the tops of the adjacent covers. Once installation is complete, the inside corner should fit snugly and the seam formed by the corner and the covers should be smooth and uninterrupted.

The external corners are a single piece with tabs at the top and a tab clip at the bottom. To install please ensure that the back plate is fixed to the two opposing wall surfaces with a maximum gap from the corner of no more than 75mm. Place the bottom tab clip under the adjacent covers. Then angle the outside corner up so that the top tabs snaps in between the wall and the covers of the tops of the adjacent covers. Once installation is complete, the outside corner should fit snugly and the seam formed by the corner and the covers should be smooth and uninterrupted.

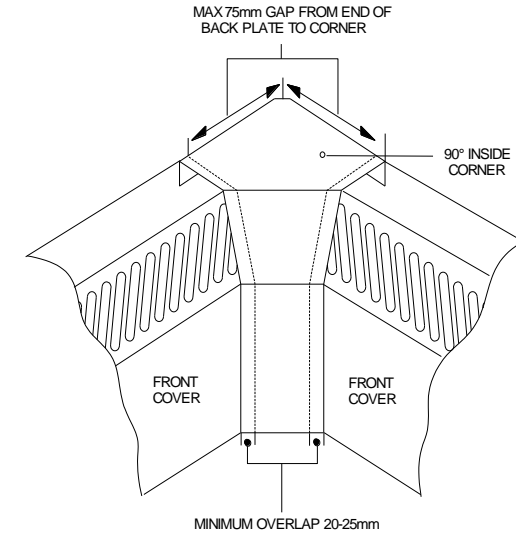

90° & 135° external corners

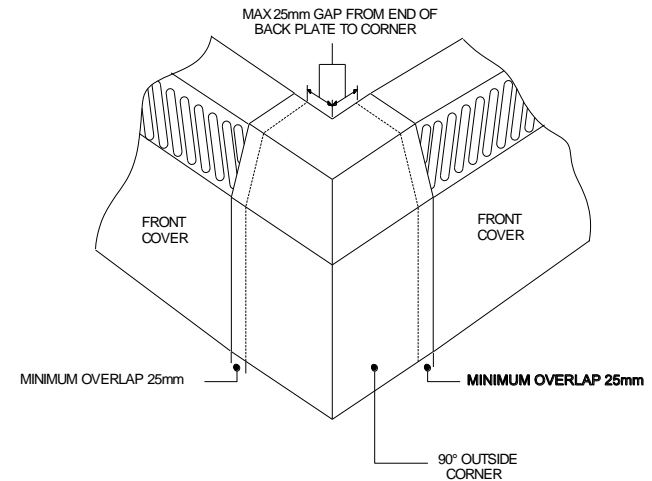

Guarantee Statement

Thank you for purchasing a Smith's heater.

It has been designed and manufactured to the highest quality standards to ensure it gives you efficient and trouble-free service for many years.

To back up our commitment, included with your product is a **free five year parts and labour guarantee.**

This gives you peace of mind that in the unlikely event of the product failing within the first five years, we will repair or replace the product completely free of charge provided the product has been installed, used and maintained in accordance with the instructions.

It is important to register within 7 days. This will ensure you receive a prompt and efficient service, if your product requires attention within the guarantee period. If you do not register your product, you will be required to produce a proof of purchase prior to receiving this service.

If you experience any problems with the use of your product, please contact our **after-sales office** on 01245 324560.

Smith's Environmental Products Ltd manufactures a complete range of heaters for domestic and commercial applications.

If you require any further information, please contact us on **01245 324900** or visit our website at **www.SmithsEP.co.uk**

Your statutory rights are not affected by this guarantee.

Please pull this Registration card from the booklet and fill in all parts and return.

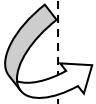

please fold along here



Smith's Environmental Products Ltd

Units 1 & 2 Blackall Industrial Estate

Hamberts Road

South Woodham Ferrers

Chelmsford

Essex

CM3 5UW

**Please
affix
stamp
here**

User Details

User Name Mr/Mrs/Miss/Ms/Other

Initials Surname

Address

.....

..... Post Code:

Telephone:

Product & Model installed (e.g. Space Saver SS5)

.....

Room Installed (e.g. Kitchen):

Your details will only be held by Smiths Environmental Products Ltd and used solely to provide customer services and product information.

If you do not wish to be contacted, please put an x in the box.

Installer Details

Company name:

Principal contact: Mr/Mrs/Miss/Ms/Other:

Initials: Surname:

Address:

.....

..... Post Code:

Telephone:

Date of installation/...../.....

Room Installed (e.g. Kitchen):

Your details will only be held by Smiths Environmental Products Ltd and used solely to provide customer services and product information.

If you do not wish to be contacted, please put an x in the box.

Guarantee Registration Card & Customer Satisfaction Survey

Dear Customer

We hope our product suits all your requirements; it would help us immensely if you could find the time to fill in this form, your response will help us maintain the quality standards we all expect in today's climate.

Customer name Date ____/____/____

Email Address@.....

Product Name

Tick as appropriate

	V Good	Good	Fair	Poor
Product	<input type="checkbox"/>	<input type="checkbox"/>	<input type="checkbox"/>	<input type="checkbox"/>
Delivery	<input type="checkbox"/>	<input type="checkbox"/>	<input type="checkbox"/>	<input type="checkbox"/>
Sales & Ordering	<input type="checkbox"/>	<input type="checkbox"/>	<input type="checkbox"/>	<input type="checkbox"/>
Response to any problems	<input type="checkbox"/>	<input type="checkbox"/>	<input type="checkbox"/>	<input type="checkbox"/>

Comments

.....

.....

.....

Thank you for your time to fill in this survey, the response will help us to serve your needs more effectively. Please return by fax to 01245 324422.

Compliance Officer: David Lee

david.lee@smithsep.co.uk