

Caspian[®] UVC EC Variants

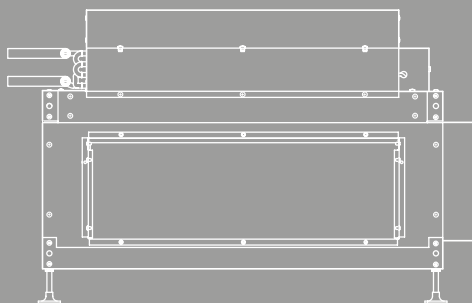

Installation, commissioning
and user manual



60 | 90 | 120 | 150 | 180
EC Series Fan Convectors

Contents

Introduction	2
Declaration of conformity	3
Symbols used in this guide	3
Important safety and installation instructions	4
Product Information	6
Product dimensions	6
Product performance	7
Mounting options	10
Wiring diagrams	12
Installation	13
Commissioning	15
Heating operation	15
Maintenance	15
Surface and suspended mounting	16
Fault finding	17
Spares	17
Accessories	17
Registering your product	18
Disposal	18
After sales	18

Introduction

Suitable for Caspian (UVC)

These heaters **must not** be installed in wet rooms or other high humidity areas.

These heaters are designed for use on standard two-pipe pumped central heating systems with a maximum water temperature of 86°C and a maximum pressure of 6 bar (88lbs/in.).

Pipe connections are 22mm, in order to obtain maximum efficiency and output the flow should be connected to the header tube which is nearest the exiting air side of the heat exchanger.

These heaters are classified as a fixed appliance and the electrical connection should be via a 3A fused spur. The fused spur must not be directly below the heater but should be accessible after completion of the installation. All heaters must be earthed.

It is recommended that this heater is wired via a remote room thermostat.

To avoid the possibility of vibration these units must be fitted to a flat even surface.

This heater is fitted with a 35°C Low Temperature Cut-out (LTC). An adjustable low temperature cut-out is also available (see page 10).

To conform to Building Regulations Part L (Part J in Scotland), a remote room thermostat can be used in conjunction with this heater. Refer to the instructions supplied with the thermostat.

Please note the guarantee may be invalidated if this product is not installed and used in accordance with these instructions.

Declaration of conformity

EC Declaration of conformity

We, Smith's Environmental Products Limited
1-2 Blackall Industrial Estate
South Woodham Ferrers
Chelmsford
Essex CM3 5UW
Tel: 01245 324900 Fax: 01245 324422

Declare under sole responsibility that the products:

Product name:
Caspian Universal

Product range:
**Caspian UV, Caspian FF, Caspian EXT,
Caspian SL, Caspian TT, Caspian UVC,
Caspian LST sizes 60, 90, 120, 150 & 180**

Conform to the following European
Union directives:
**Low Voltage Directive 2014/35/EU
Safety of household electrical appliances: EN
60335-2-30:2009, +A11:12
EN 60335-1:2012/AC:14+A11:14
EN 62233:2008**

**Electromagnetic compatibility (EMC)
EN 55014-1:2006 inc. A1:2009 & A2:2011
EN61000-3-2:2006 inc A1/A2:2009
EN61000-3-2:2014
EN61000-3-3:2013**

This Declaration is made on behalf of Smith's
Environmental Products Limited.

Symbols

This manual contains information and
prescriptions marked by the following symbols.



Ignoring these safety provisions
marked by the symbol "caution:
hazard" may endanger the safety
of people.



Ignoring these safety provisions
marked by the symbol "caution:
electricity" may endanger the
safety of people, as well as the
integrity of things.



The removal of the screws can
cause the output of hot fluids
under high pressure from heating
system. Drain the system or close
the isolating valves.



High temperature surface. Take
utmost care to prevent people
from getting in contact with the
hot surfaces of the appliance.

Important safety and installation instructions

Prior to installation, read these installation and operating instructions. The installation and operation should also be in accordance with national regulations and accepted codes of good practice.



This appliance is not intended for use by persons (including children) with reduced physical, sensory or mental capabilities, or lack of experience and knowledge, unless they have been given supervision or instruction concerning use of the appliance by a person responsible for their safety. Children should be supervised to ensure that they do not play with the appliance.

To guard against injury, basic safety precautions should be observed, including the following:

1. Read and follow all safety instructions and all the important notices on the appliance before installing, using and maintaining the appliance. Failure to do so may cause personal injury or damage to the appliance or installation.
2. Always disconnect electrical supply before putting on or taking off parts and whilst the equipment is being installed, maintained or handled. Never work with bare feet and/or with wet hands.
3. To avoid possible electric shock, special care should be taken since water is used with electrical equipment. Carefully examine the appliance before and after installation. Do not operate the appliance if it has a damaged supply cord or enclosure, or if it is malfunctioning or it is dropped or damaged in any manner. Inspect the appliance periodically.



The appliance should not be electrically supplied if there is water on parts not intended to be wet.

4. Risk of scalding. To avoid injury before any servicing operation wait until the water has cooled inside the appliance. Do not touch the fluid or the appliance when temperature is higher than 60°C.
5. Improper use.
This is an appliance to be used in heating systems with clean water without abrasive particles.



Do not use this appliance:

- With liquids other than water (e.g. flammable liquids, etc.) (EN60335-2-51);
- In locations where special conditions prevail, such as the presence of a corrosive or explosive atmosphere (dust, vapour or gas) (EN60335-2-51);
- For other than intended use.

6. Installation.

The appliance must be mounted in a stable/fixed position in a dry, well ventilated, frost-free, waterproof and protected place, with sufficient ventilation around it. Make sure that the appliance is securely and correctly installed before operating it and that there is enough room around it for maintenance operations, dismantling, checking for free inspection.

The maximum ambient temperature at which the appliance is to be used is 40°C (EN60335-2-51).



7. Electric connection

IMPORTANT: Connection to the power supply must be effected by means of a fixed power cable which is fitted with a plug-type connection or a two pole isolating switch with a minimum contact opening of 3 mm.

Electrical connection must be carried out by a qualified electrician and in accordance with local regulations and both data on the name-plate and the appropriate diagram inside the terminal box cover.

Follow all safety standards.

8. All electrical work should be carried out in accordance with current IEEE regulations; we recommend the appliance is protected by a Residual Current Device (RCD or Ground-Fault Circuit-Interrupter) with a rated residual operating current not exceeding 30mA.

9. Prior to any modification being made to the equipment, it must be agreed with and authorised by the manufacturer. Original spare parts and accessories authorised by the manufacturer are integral part contributing to the safety of the equipment and of the machines. The use of non original components or accessories may endanger the safety and causes the termination of the warranty. Safe operation is only assured for the applications and conditions described in Application of this manual.

Non-observance of the safety instructions results in the loss of any claims to damages.

The indicated limit values are binding and cannot be exceeded for any reason whatsoever.

KEEP THESE INSTRUCTIONS FOR FUTURE REFERENCE.

Introduction

The unit is supplied in a standard mode which includes a rectangular air outlet duct, a rectangular air inlet duct (not fitted) and four mounting feet (not fitted).

Dependent on the installation you may require right angle ducts, extension ducts, double / triple spigot outlets and grilles, these items and ancillary controls are supplied as accessories (listed on page 11) and should be added to your order if required.

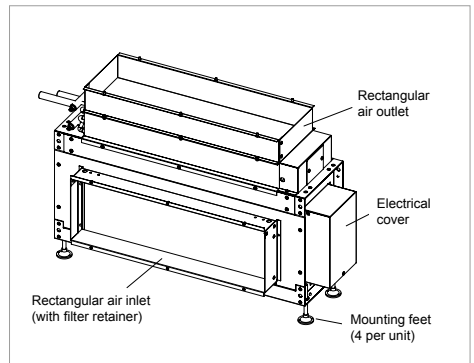

Product dimensions

UVC Heater

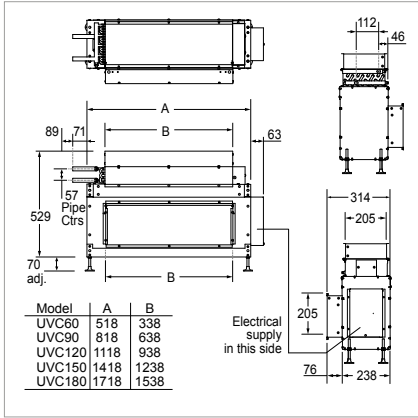

Accessory Grilles (Optional)

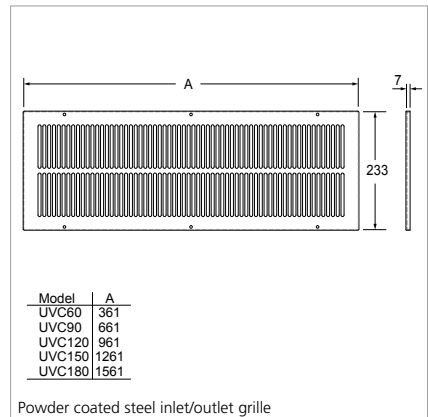
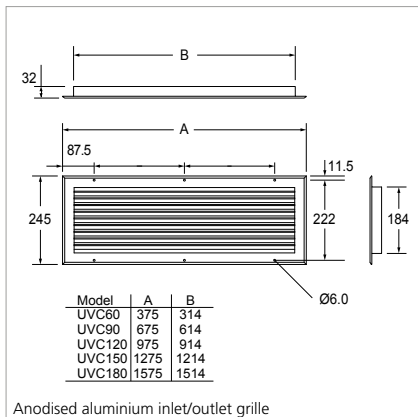
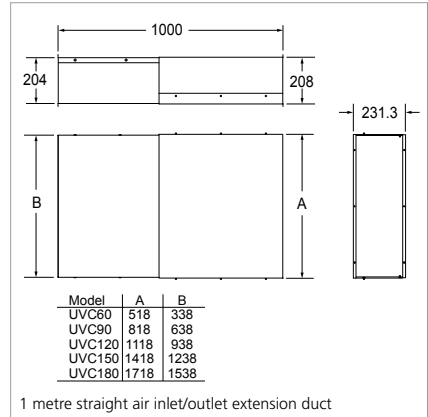
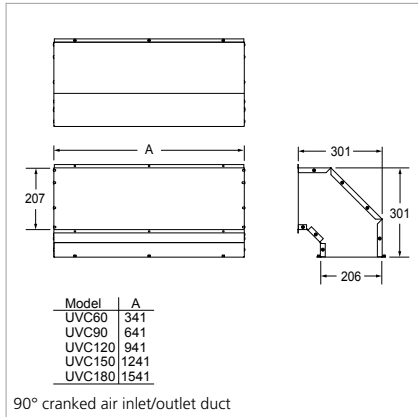
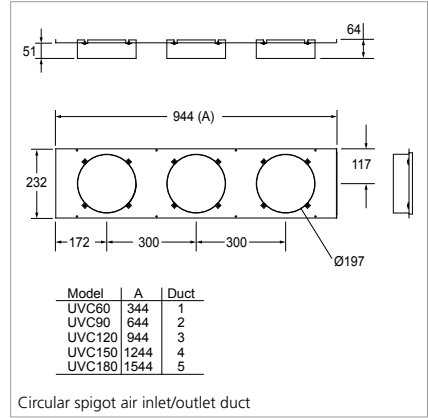

Product performance

Heat output - EC

Model Reference	Fan Speed	Control Voltage VDC	40°C MWT	45°C MWT	50°C MWT	55°C MWT	60°C MWT	65°C MWT	70°C MWT	75°C MWT	80°C MWT
EC 60	Low	3.4	0.85	1.20	1.45	1.80	2.16	2.35	2.73	3.08	3.40
	Mid	4.9	1.02	1.53	1.92	2.37	2.76	3.18	3.58	4.05	4.38
	High	6.4	1.18	1.85	2.38	2.93	3.36	4.00	4.43	5.02	5.36
EC 90	Low	3.2	1.68	2.23	3.01	3.49	4.05	4.45	5.12	5.49	6.03
	Mid	4.6	2.22	3.07	4.05	4.66	5.42	6.01	6.81	7.34	7.93
	High	6.1	2.75	3.90	5.08	5.82	6.78	7.56	8.49	9.19	9.83
EC 120	Low	3.1	1.62	2.34	3.32	3.98	4.71	5.62	6.32	6.99	7.61
	Mid	4.3	2.31	3.25	4.27	5.15	6.07	7.02	7.91	8.74	9.60
	High	5.5	2.99	4.15	5.21	6.31	7.42	8.41	9.50	10.48	11.59
EC 150	Low	2.8	2.95	3.72	4.49	5.27	6.045	6.79	7.54	8.29	9.04
	Mid	4.0	3.99	4.99	5.99	6.99	7.97	8.99	9.97	10.98	11.93
	High	5.1	5.02	6.26	7.49	8.71	9.90	11.19	12.39	13.67	14.82
EC 180	Low	2.8	3.64	5.20	6.78	8.24	9.39	10.33	11.24	12.15	13.01
	Mid	3.9	4.51	6.18	7.85	9.51	10.95	12.36	13.70	15.07	16.40
	High	4.9	5.38	7.16	8.91	10.77	12.50	14.39	16.16	18.0	19.78

Model Reference	Fan Speed	Air Volume (m³/h)	Air Volume (l/s)	Specific Fan Power w/l/s	Power Consumption (W)	NR in typical room*
EC 60	Low	201.00	55.90	0.14	8.00	34.00
	Mid	290.50	80.75	0.26	21.00	41.50
	High	380.00	105.60	0.32	34.00	49.50
EC 90	Low	297.00	80.75	0.20	16.00	34.00
	Mid	450.50	124.38	0.34	42.00	41.50
	High	604.00	168.00	0.40	68.00	49.97
EC 120	Low	419.30	116.50	0.14	16.00	34.00
	Mid	549.65	152.68	0.26	40.00	42.00
	High	680.00	188.89	0.34	64.00	49.96
EC 150	Low	459.80	127.72	0.17	22.00	34.70
	Mid	598.10	166.14	0.35	59.00	41.50
	High	736.40	205.56	0.47	96.00	49.38
EC 180	Low	542.00	150.56	0.19	29.00	34.90
	Mid	690.00	191.67	0.40	78.50	41.50
	High	838.00	232.78	0.55	128.00	49.00

*a typical room is taken as a room with a volume of 173m³ and a reverberation time of 0.8 seconds at 500 Hz with one unit installed, situated against a wall or ceiling (radiating noise in a quartersphere). No allowance is made for attenuation provided by ceilings, enclosures or ductwork. Outputs based upon testing at EN442: 2014 using mean water temperature and an entering air temperature of 20°C with a 10°C temperature drop between flow and return.

Product performance

Model Reference	Fan Speed	Hydraulic Resistance (KPA)	Nominal Weight (KG)	Water Capacity (L)
EC 60	Low	1.38	23.00	0.92
	Mid	1.69		
	High	2.00		
EC 90	Low	4.70	36.00	1.50
	Mid	5.85		
	High	7.00		
EC 120	Low	17.78	45.00	2.08
	Mid	20.59		
	High	23.40		
EC 150	Low	22.23	60.00	2.58
	Mid	29.46		
	High	36.69		
EC 180	Low	47.83	78.00	3.18
	Mid	60.76		
	High	73.70		

Correction factors

Mean Water Temp °C		45 - 80			
Water Temperature drop °C		5	10	15	20
Entering Air Temperature °C	15	1.13	1.10	1.07	1.05
	18	1.08	1.05	1.02	0.99
	20	1.04	1.00	0.95	0.89
	25	0.93	0.91	0.89	0.86

Factors are approximate data based upon a standard coil.

How to calculate Mean Water Temperature (ΔT)

$$\text{Mean water temperature } (\Delta T) = \left[\frac{\text{Flow temperature} + \text{Return temperature}}{2} \right] - \text{Ambient Temperature}$$

Mounting Options

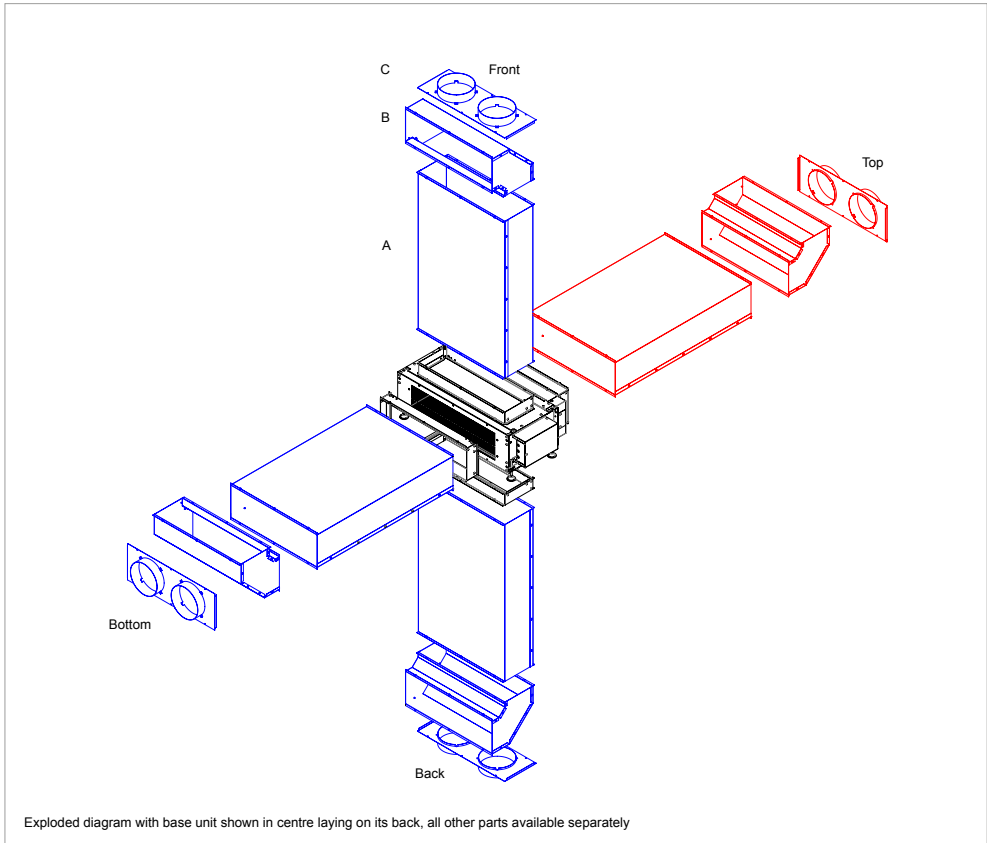

Fix the unit to the ceiling or wall via suitable fixings. If fitted to suspended ceilings or similar then suitable means of support such as threaded rods or chains must be used.

The unit may be orientated so that the discharge blows up or downwards to suit installation requirements.

To ensure long term function ensure the unit is installed in the horizontal plane – running in the vertical plane may reduce fan life.

Optional extras and accessories

Air Inlet: air inlet should be through one of 3 options (front, bottom, back inlet) shown in blue

If air inlet is not through the front of the unit the filter retainer should be moved to the required position

Air Outlet: air outlet must always be through the top of the unit shown in red.

By fitting optional equipment this product can operate automatically under normal running conditions. The optional controls fit within the casing of the unit and are supplied with easy to fit instructions.

Inlet / Outlet Ducting & Grilles	
Straight 1 Metre Duct (Marked as "A" in exploded diagram, See page 10) A Straight 1 Metre duct for either inlet/ outlet of the product. May be cut to size if necessary. Available sizes (90/120/150 &180)	STR1MDCT
90 Degree Duct (Marked as "B" in exploded diagram, See page 10) A 90 degree duct used to turn entering/ exiting air of the product, for either inlet/outlet. Available sizes (90/120/150 &180)	90DEGDCT
200mm Spigot Adaptor (Marked as "C" in exploded diagram, See page 10) Spigot adaptor that will fit either directly to the heater or an accessory duct. Size 90 x 2 Spigots, Size 120 x 3 Spigots, Size 150 x 4 spigots and size 180 x 5 spigots	200SGAD
Punched Steel Grille Punched steel grille for either inlet/ outlet. Painted in white polyester powder coat (RAL 9010). Available sizes (90/120/150 &180)	PSG
Aluminium Linear Grille Aluminium framed louvre grille for either inlet/ outlet. Available sizes (90/120/150 &180)	ALG
Electrical Controls	
Proportional Heat Output controller As the room temperature increases to a comfortable temperature the fan speed of the unit will reduce. This replaces the standard unit controller. (This controller is pre-set and non-adjustable)	PHOC
External Control Harness Allows for the standard unit controller to be relocated externally from the heater	EXTCH
Adjustable low temperature cut-out This enables the end user to precisely select the temperature at which the fans will switch on when combined with different heat sources.	ALTC T3
Wall Mounted Controller This enables the end user to control the fan speed from a wall mounted control.	WMCEC
Miscellaneous	
Caspian 22mm Flexible Hoses	CAS22FH

For accessories or spares please contact either your supplier or Smith's Environmental Products Ltd.

Wiring diagrams

Caspian Concealed Recessed 90 / 120 Wiring Diagram

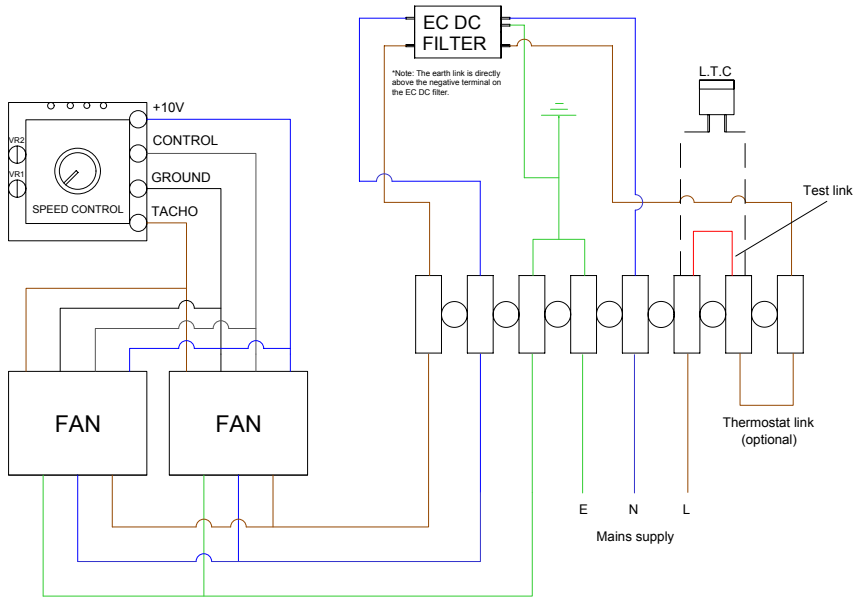

Note: Additional fans wired in parallel (150/80 models)

Note: If your heater was built before October 2014 or the colours shown in this diagram do not match those on your unit please refer to the below Key:

+10V (Red)	=	Blue
Control (Yellow)	=	Grey
Ground (Blue)	=	Black
Tacho (White)	=	Brown

Test link

Each heater is fitted with a test link to ensure the correct function of the unit before connecting the heat exchanger to the hot water system.

This link should be removed and the LTC wires (Shown as dashed lines) fitted in its place.

1. Isolate the unit from the electrical supply and remove the front panel
2. Locate the electrical panel and remove and discard the red test wire.
3. Connect the low temperature cut-out (LTC) wires in place of the red test wire
4. Re-attach the front panel and re-energise the power supply

Failure to remove the test link and fit the LTC wires will cause the unit to run continuously

Installation

1. Unscrew electrical panel

Unscrew electrical panel to and any packing pieces from the product.

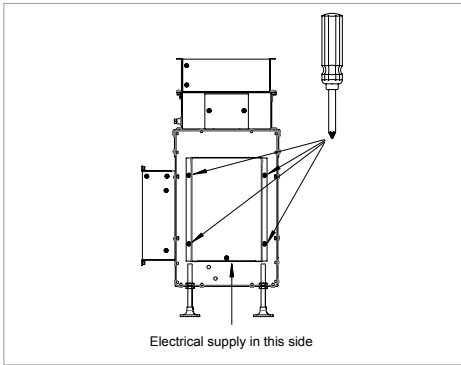

2. Fix unit to wall or ceiling

Fix the unit to the ceiling or wall via suitable fixings. If fitted to suspended ceilings or similar then suitable means of support such as threaded rods or chains must be used.

3. Connect the pipes

Connect the heating system flow and return pipes to the heater pipe work. Pipe entry/exit can be made through either the back of the unit or by using the pipe knockouts on the bottom of the unit. Do not use soldered fittings to the heater pipe work as the heat generated may cause damage to internal wiring and components. Compression fittings should be used.

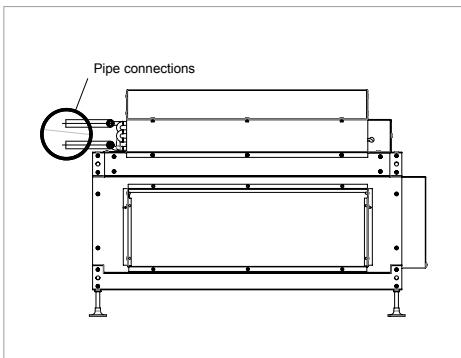

Note: We recommend the use of full-flow service valves. The valves should be accessible after completion of the installation. We also advise the fitting of an air vent at the highest point on either the flow or return pipe to remove any air trapped within the system.

4. Open the service valves

Open the full flow service valves and check for water leaks. Remove any trapped air from the unit via the built in bleed screws as shown in the diagram below.

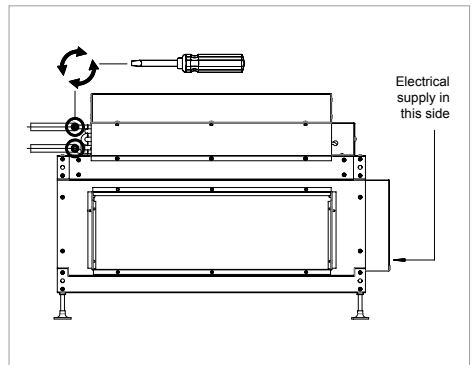

5. Electrical supply

Isolate the electrical supply

6. Connect the power supply

Connect the power supply from the fused spur (3 Amp) to the heater terminal block marked Supply E N L via the cable entry hole in the top chassis of the heater.

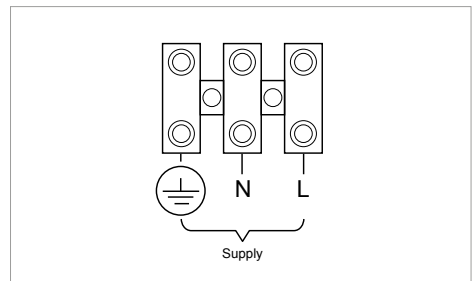

The fused spur must not be directly below the heater and must be accessible after the installation is complete. All electrical work should be carried out in accordance with current IEEE regulations.

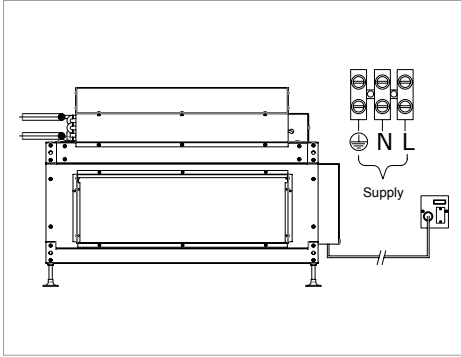

7. Connect a room thermostat

To connect a room thermostat (not supplied)

1. Isolate the electrical supply
2. Unscrew and remove electric panel
3. Remove link wire shown in the wiring diagram and fit thermostat wires
4. Refit electric panel

For further information refer to the room thermostat manufacturers instructions.

Accessory installation

A wide range of accessories are available, most of which are factory fitted. However, if an accessory has been purchased as a separate item, the installation instructions can be found on our website.



<https://smithsep.co.uk/wp-content/uploads/2016/09/Smiths-Caspian-Universal-Adjustable-low-temperature-cut-out-T3.pdf>



<https://smithsep.co.uk/wp-content/uploads/2016/09/Smiths-Caspian-Universal-External-Control-Harness-Installation-and-User-Guide.pdf>



<https://smithsep.co.uk/wp-content/uploads/2016/09/Smiths-Caspian-Universal-Proportional-Heat-Output-Controller-Installation-and-User-Guide.pdf>

Commissioning

1. Turn on the electrical supply at the fused spur.
2. Turn the thermostat control (if fitted) to maximum.
3. Turn on the central heating system.
4. Where an adjustable LTC has been fitted, set it to the desired temperature.
5. If these heaters are installed on the same circuit as panel radiators balance the central heating system.
6. If the installation is working correctly remember to reset the thermostat control (if fitted) to its normal setting.
7. Set the fan speed control to the desired position. Note: Not applicable if fitted with a Proportional Heat Output Controller (PHOC).

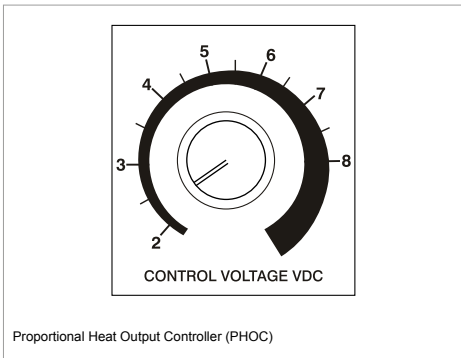

8. Set the dial to the speed required by referencing the table included with the product and shown below.

CASPIAN EC FAN SPEED VOLTAGE SETTINGS VDC					
Model	60	90	120	150	180
Low Speed	3.4	3.2	3.1	2.8	2.8
Mid Speed	4.4	4.6	4.3	4	3.9
High Speed	6.6	6.1	5.5	5.1	4.9

Fan speed settings label

9. Lift up and close front access panel, ensure this is secure and locked in place with keys provided.
10. Please leave this Installation & User Guide with the user for future reference.

Heating operation

Ensure the central heating system is ON. Switch on the power supply to the unit. Set the thermostat control (if fitted) to the desired temperature. Providing the water temperature in the central heating system is more than 38°C and the thermostat (if fitted) is calling for heat the product will switch on.

It is recommended that the model chosen is capable of maintaining the calculated heat loss at medium heat output enabling the high speed setting to be used for faster heat up and the low speed for maintaining temperature.

Maintenance

Warning! Isolate from the electrical supply before performing any work on the unit.

The internal air filter is removable for servicing. To gain access to the filter unlock and lower the front access panel, remove the 2 screws from the filter enclosure panel and lift out. Carefully lift out and remove filter. The filter should be gently tapped to remove any accumulated dust and vacuumed if necessary (approx. every 6 months). We recommend replacing the filters approx. every 2 years depending on environmental conditions.

The coil fins are delicate so take care and only use a soft brush or vacuum cleaner to remove any dust that may have accumulated.

The fan(s) and motors should not require servicing. Please contact your supplier if damaged.

To replace filter use reverse the removal instructions and ensure the lower front access panel is securely locked.

Please note in the event of an engineer's visit, Smith's Environmental Products Ltd reserve the rights to apply a call-out charge should the fault prove to be with the system or installation and not the heater appliance.

Surface mounting

1. Fit feet (supplied) to the unit at the appropriate height and position and drill suitable size holes through the plastic base of the foot to secure.
2. Stand unit on batons (not supplied) and mark position of batons and feet.
3. Remove unit if necessary and fix batons to surface area (floor or other)
4. Mount unit on batons and fix feet to batons with appropriate fixings.
5. Connect unit to pipework (appropriate service valves should be fitted at this point, unless already on flow and return pipework).
6. Open valves from the hot water system to the heater and check for leaks.
7. Identify the electrical (connection) cover on the end of the heater and remove. (see fig. 1)
8. Connect unit to an appropriate electrical supply via a 3amp fused spur.
9. Connect any ancillary controls to appropriate connections on heater.
10. Refit cover.
11. Switch on electrical supply and heating.
12. Test heater functions are working correctly and remove test link and fit Low temperature cut-out (LTC) wires (See page 12).
13. Switch off electric supply and fit appropriate ducts and / or extensions to the heater and install any front covers or ceiling sections.
14. Install appropriate inlet and outlet grilles.

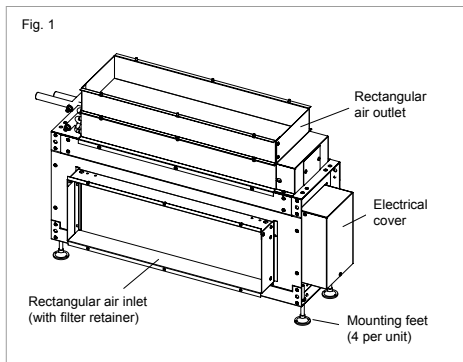

Suspended mounting

1. Decide on elevation of heater and note which part of the heater will be facing upwards.
2. Fit suitable fixings to attach the chains or threaded rod to the ceiling or prepared hanging brackets.
3. If using chains fit appropriate hanging eyes to the upside of the unit. (not supplied)
4. Connect heater to chains or rods and secure.
5. Connect heater to pipework. (Appropriate isolation valves should be fitted at this point unless already fitted to flow and return pipework).
6. Open valves from the hot water system to the heater and check for leaks
7. Identify the electrical connection cover on the end of the heater and remove. (see fig. 1)
8. Connect to an appropriate electrical supply via 3amp fused spur.
9. Connect any ancillary controls to appropriate connections in the heater.
10. Refit cover.
11. Switch on electrical supply and heating.
12. Test heater functions are working correctly and remove test link and fit Low temperature cut-out (LTC) wires (See page 12).
13. Switch off electric supply and fit appropriate ducts and /or extensions flexible or rigid to the heater.
14. Install appropriate air inlet / outlet grilles and attach to ducts.
15. Switch on electrical supply, heating and any ancillary controls and test unit functions.

Please note this unit is fitted with a low temperature cut out that will not let the unit function when the water temperature in the unit is below 35°C.

Fault finding

Providing the power supply is switched on the room thermostat (if fitted) is calling for heat the heater will switch on and off automatically with the central heating system.

In the event of any difficulty, please contact us on +44 (0) 1245 324560.

It will be helpful if you do not disconnect the heater from the central heating system.

Fault	Checking/Solution
The fan does not run on any speed setting	<p>Check the power supply is switched ON</p> <p>Check the fuse in the fused spur</p> <p>Check the wiring at the fused spur</p> <p>If thermostat is fitted ensure it is calling for heat</p> <p>Check the central heating is switched ON</p> <p>Vent any trapped air from the system (with the heating system turned OFF)</p>
No heat output	<p>Check flow and return pipes are hot</p> <p>Vent any trapped air from the system (with the heating system turned OFF)</p> <p>Check the central heating is switched ON</p> <p>If a thermostat is fitted ensure it is calling for heat</p> <p>Balance the central heating system if installed on the same circuit as panel radiators and increase the circulating pump speed if required</p> <p>Increase the boiler water temperature</p>

Spares

See the table below to find the product code for any spares that maybe required for your Caspian product.

Component	Model				
	60	90	120	150	180
UVC Filter x 1	03-6015	03-6016	03-6017	03-6041	03-6043
Fan	06-0321 x 1	06-0321 x 2	06-0321 x 2	06-0321 x 3	06-0321 x 4
Coil	02-0301	02-0303	02-0304	02-0343	02-0382

Accessories

Smith's offer a range of accessories which can be used in conjunction with this product. This includes:

Remote Room Thermostats (wired and wireless inc tamper proof option)

Remote (wired) room thermostat Siemens speed and temperature control

Wall mounted control switch

Adjustable low temperature cut-out (LTC)

Plinth (for floor standing application)

Caspian linking kits (EC only)

External control harness (EC only)

Proportional heat output controller (PHOC)

Thermostat T1

Flexible hoses and quick connector kits

For further information on accessories or spares please contact either your supplier or Smith's Environmental Products Ltd or visit www.SmithsEP.co.uk

Registering your product

Thank you for purchasing a Smith's product. It has been designed and manufactured to the highest quality standards to ensure it gives you efficient and trouble-free service for many years. We are committed to achieving the highest standards and our faith is supported by a free parts and labour guarantee with every product.

For more information on the warranty period for this product please visit our website smithsep.co.uk/product-registration/

This gives you the peace of mind that in the unlikely event of product failure, we will repair or replace the product completely free of charge providing the product has been installed, used and maintained in accordance with the instructions. Your statutory rights are not affected by this warranty.

It is important to register as soon as possible online at: smithsep.co.uk/product-registration/. This will ensure you will receive prompt and efficient service if your product requires attention within the warranty period. If you do not register your product, you will be required to produce proof of purchase prior to receiving service.

For more details please visit our website:
SmithsEP.co.uk

SCAN HERE TO REGISTER
YOUR PRODUCT

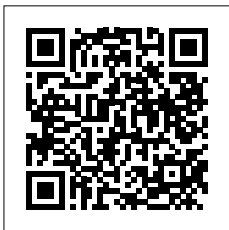

Disposal

As part of the policy of continuous product improvement, Smith's Environmental Products LTD reserves the right to alter specification without prior notice.

Products with this symbol (crossed out wheellie bin) cannot be disposed as household waste. Old electrical and electronic equipment must be recycled at a facility capable of handling these products and their waste by-products. If you are purchasing replacement equipment your retailer may offer a 'take back' scheme, or will be able to give details of the nearest approved authorised treatment facility. Proper recycling and waste disposal will help conserve resources whilst preventing detrimental effects on our health and the environment.

WEEE Registered Code: WEE/ED0093VW



Approved CQS ISO
9001:2015



ISO 14001

After sales

If you experience any problems with the use of your product, please contact our after-sales office +44 (0) 1245 324560.

For product information, customer services or sales support call us on +44 (0) 1245 324900

For the Republic of Ireland, contact MT Agencies on 01 864 3363

Sales: sales@SmithsEP.co.uk

General information: info@SmithsEP.co.uk

Smith's Environmental Products Ltd
Blackall Industrial Estate, South Woodham Ferrers,
Chelmsford, Essex CM3 5UW

SmithsEP.co.uk

[@SmithsEP_UK](https://twitter.com/SmithsEP_UK)

[#ThinkSmiths](https://www.facebook.com/ThinkSmiths)

Notes



Happy to help

Smith's Environmental Products Ltd is one of the leading manufacturers of heating and cooling products in the UK. We are committed to achieving the highest standards and our faith is supported by a free parts and labour guarantee with every product (see our website for more information). Our customer service is second to none and we are happy to offer any help and guidance that you might need.

Stockists

All products are available nationally from Builders' Merchants, Plumbers' Merchants, Heating Equipment Distributors and Kitchen Equipment Distributors. In the event of difficulty, please contact us or visit our website SmithsEP.co.uk for details of your nearest stockist.

Information and advice

Full technical specifications and list prices is available to download from our website or in hard copy from our office. Also available on our website are price lists, individual product data sheets, installation & user guides, where to buy, who to contact and a media centre.

Alternatively contact our office 9.00am to 5.00pm Monday to Friday.

As part our commitment to continuous improvement Smith's Environmental Products may change the specifications of its products without prior notification or public announcement. All descriptions, illustrations, drawings and specifications in this publication present only general particulars and shall not form part of any contract. All dimensions are in mm unless otherwise stated. Please visit the website for the most up to date information.

**To view the full product information download the datasheet at:
www.SmithsEP.co.uk**

For product information, customer services or sales support call us on **+44 (0) 1245 324900**

For the Republic of Ireland, contact MT Agencies on 01 864 3363

Sales: sales@SmithsEP.co.uk

General information: info@SmithsEP.co.uk

Smith's Environmental Products Ltd
Blackall Industrial Estate, South Woodham Ferrers,
Chelmsford, Essex CM3 5UW

SmithsEP.co.uk

[@SmithsEP_UK](https://twitter.com/SmithsEP_UK)

[#ThinkSmiths](https://www.facebook.com/ThinkSmiths)

Issue 001 | 85-0062 | October 2023