

# Caspian® CTFF

Education | Healthcare | Leisure and sport | Office | Hospitality | Retail | Showroom



**Caspian CTFF fits into 600mm x 600mm or 600mm x 1200mm ceiling tile, providing easy access for both installation and maintenance**

Caspian fan convectors are both a practical and high quality heating solution for any commercial project

Incorporating the latest EC motor technology, which can result in running-cost savings as high as 70%, and with variable speed control as standard, the Caspian delivers heat quickly and quietly.

It is possible to have master and slave Caspian fan convectors that integrate the entire range of EC Caspian products. Please contact either our sales team or technical team to ensure that this is correctly specified

Caspian fan convectors are compatible with most types of wet central heating systems, functioning equally efficiently with conventional boilers, biomass technology or ground or air source heat pumps

EC versions are now available with Caspian Smart Controls, for more information please visit our website: <https://smithsep.co.uk/catalogue/caspian-smart-controls/>



## Product Information

### Motor

EC (BMS compliant).

### Finish

Casing: zinc-coated steel 1.2mm.  
Polyester powdercoated: white RAL 9010.  
Available to special order in any colour.

### Filter

Class G2, 100% polyester, non-washable.

### Installation

Suitable for two-pipe central heating systems.  
Maximum installation height for high or ceiling mounting, - 4m to underside.  
Pipework access holes on the rear and underside.  
Key operated front access panels.  
Bleed valve accessible on removal of front casing.  
Unit must be earthed.

### Commissioning

Check water is hot enough to activate the low temperature cut-out thermostat.

### Controls

See accessories table.

### Specification

To specify state:

Fan Convector with EC motor (or AC), in 1.2mm zinc coated steel, 595mm x 595mm or 595mm x 1195mm. With variable heat output controller. As Smith's Caspian CTFF60/120

## Technical Data

### Heat output - EC

Model Reference	Fan Speed	Control Voltage VDC	40°C MWT	45°C MWT	50°C MWT	55°C MWT	60°C MWT	65°C MWT	70°C MWT	75°C MWT	80°C MWT
EC 60	Low	3.4	0.85	1.20	1.45	1.80	2.16	2.35	2.73	3.08	3.40
	Mid	4.9	1.02	1.53	1.92	2.37	2.76	3.18	3.58	4.05	4.38
	High	6.4	1.18	1.85	2.38	2.93	3.36	4.00	4.43	5.02	5.36
EC 120	Low	3.1	1.62	2.34	3.32	3.98	4.71	5.62	6.32	6.99	7.61
	Mid	4.3	2.31	3.25	4.27	5.15	6.07	7.02	7.91	8.74	9.60
	High	5.5	2.99	4.15	5.21	6.31	7.42	8.41	9.50	10.48	11.59

Model Reference	Fan Speed	Air Volume (m³/h)	Air Volume (l/s)	Specific Fan Power w/l/s	Power Consumption (W)	NR in typical room*	Hydraulic Resistance (KPA)	Nominal Weight (KG)	Water Capacity (L)
EC 60	Low	201.00	55.90	0.14	8.00	34.00	1.38	23.00	0.92
	Mid	290.50	80.75	0.26	21.00	41.50	1.69		
	High	380.00	105.60	0.32	34.00	49.50	2.00		
EC 120	Low	419.30	116.50	0.14	16.00	34.00	17.78	45.00	2.08
	Mid	549.65	152.68	0.26	40.00	42.00	20.59		
	High	680.00	188.89	0.34	64.00	49.96	23.40		

\*a typical room is taken as a room with a volume of 173m³ and a reverberation time of 0.8 seconds at 500 Hz with one unit installed, situated against a wall or ceiling (radiating noise in a quartersphere). No allowance is made for attenuation provided by ceilings, enclosures or ductwork. Outputs based upon testing at EN442: 2014 using mean water temperature and an entering air temperature of 20°C with a 10°C temperature drop between flow and return.

### Correction factors

Mean Water Temp °C		45 - 80			
Water Temperature drop °C		5	10	15	20
Entering Air Temperature °C	15	1.13	1.10	1.07	1.05
	18	1.08	1.05	1.02	0.99
	20	1.04	1.00	0.95	0.89
	25	0.93	0.91	0.89	0.86

Factors are approximate data based upon a standard coil.

### How to calculate Mean Water Temperature

$$\text{Mean water temperature } (\Delta T) = \frac{\text{Flow temperature} + \text{Return temperature}}{2}$$

### Dimensions

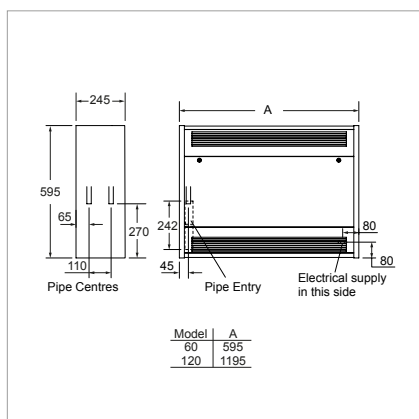

### Ordering Guide

Model	Packed Wt (kg)	Product Code
CASPIAN CTF60EC	23	HPCA29004
CASPIAN CTF60 C/W REMOTE SMART CONTROL	23	HPCA30005
CASPIAN CTF120EC	45	HPCA29003
CASPIAN CTF120 C/W REMOTE SMART CONTROL	45	HPCA30004
Accessories		
FLEXIBLE HOSES 22MM PAIR		HAGA95003
ROOM THERMOSTAT HARD WIRED		HAGA95001
ROOM THERMOSTAT TAMPER PROOF		HACA95004
CASPIAN PROPORTIONAL HEAT OUTPUT CONTROLLER 15°-25° REMOTE SENSOR (EC)		HACA33037
CASPIAN PROPORTIONAL HEAT OUTPUT CONTROLLER 11°-21° REMOTE SENSOR (EC)		HACA33118
BLANK CONFIGURABLE PROPORTIONAL HEAT OUTPUT CONTROLLER (PROGRAMMED AT FACTORY)		HACA33126
CASPIAN ADJUSTABLE LOW TEMPERATURE CUT-OUT (EC AND AC)		HACA33001
CASPIAN EXTERNAL CONTROL HARNESS (EC)		HACA33004
CASPIAN EC LINKING KIT (MASTER/SLAVE)		HACA33068
CASPIAN REMOTE SWITCHING ON/OFF RELAY (24V AC COIL)		HACA33127
CASPIAN THERMOSTAT (T1) (EC & AC LOW LEVEL)		HACA33002

As part our commitment to continuous improvement Smith's Environmental Products may change the specifications of its products without prior notification or public announcement. All descriptions, illustrations, drawings and specifications in this publication present only general particulars and shall not form part of any contract. All dimensions are in mm unless otherwise stated. Please visit our website for the most up to date information.