

Ecovector® II Low

Education | Healthcare | Places of worship | Leisure and sport | Office | Hospitality | Retail | Showroom | Industrial | Residential

Ecovector II Low Level fan convectors provide warmth from a low level upwards and are more energy efficient and effective than radiators

The Ecovector II can heat up a room more quickly than radiators, thereby reducing the amount of time your boiler or heat pump is running - making it extremely efficient and cost effective

Compatible with most types of wet central heating systems, functioning equally efficiently with conventional boilers, biomass technology or ground or air source heat pumps

Ideal for new and existing developments, due to ease of installation, the Ecovector is available in a range of models to suit varying room sizes and heat output requirements



As part of our commitment to continuous improvement Smith's Environmental Products may change the specifications of its products without prior notification or public announcement. All descriptions, illustrations, drawings and specifications in this publication present only general particulars and shall not form part of any contract. All dimensions are in mm unless otherwise stated. Please visit our website for the most up to date information.

Issue 003 | January 2025

+44 (0) 1245 324 900 | sales@smithsep.co.uk | SmithsEP.co.uk

 **Smith's**
A Swan Group Company

Product information

Finish

Front casing: zinc-coated steel.
Polyester powder-coated RAL 9016.

Installation

This heating appliance is intended for mounting on a wall at low level via the chassis mounting holes. The minimum recommended installation height is 100mm from the floor. There is no clearance required on either side of the heater.

Ecovector II is designed for use on standard two-pipe pumped central heating systems where the system hot water is generated from either a boiler or renewable sources.

Commissioning

Check water is hot enough to activate the low temperature cut-out thermostat. Pair thermostat to heater.

Control

Rocker switch - low/off/high.
Wireless room thermostat to be positioned on wall.
Low temperature cut-out thermostat set to energise fan at approximately 33°C.
Fan only switch.

Specification

To specify state: Low level hydronic fan convector in white. As Smith's Ecovector II LL640/LL1030/LL1390

Dimensions

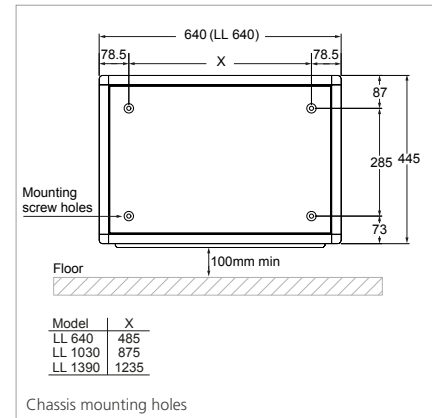
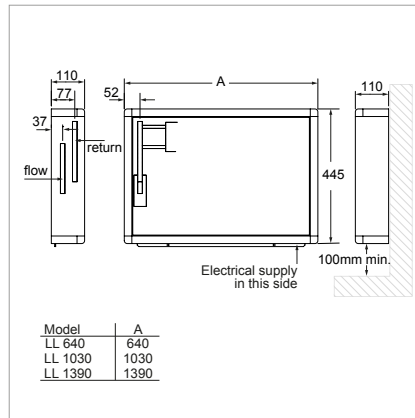

Ordering Guide

Model	Packed Wt (kg)	Product Codes
ECOVECTOR II LL 640	14	HPEV50004
ECOVECTOR II LL 1030	19	HPEV50005
ECOVECTOR I ILL 1390	26	HPEV50006

Technical Data

Heat output

Model	Heat Output at 80°		Heat Output at 75°		Heat Output at 70°		Heat Output at 65°		Heat Output at 60°	
	Low (kW)	High (kW)	Low (kW)	High (kW)	Low (kW)	High (kW)	Low (kW)	High (kW)	Low (kW)	High (kW)
ECOVECTOR II LL 640	1.2	1.45	1.1	1.32	0.98	1.19	0.9	1.07	0.8	0.94
ECOVECTOR II LL 1030	2.44	2.82	2.22	2.56	2.0	2.29	1.79	2.08	1.58	1.86
ECOVECTOR II LL 1390	3.37	4.00	3.06	3.67	2.78	3.34	2.51	3.02	2.23	2.7

Model	Heat Output at 55°		Heat Output at 50°		Heat Output at 45°		Heat Output at 40°	
	Low (kW)	High (kW)	Low (kW)	High (kW)	Low (kW)	High (kW)	Low (kW)	High (kW)
ECOVECTOR II LL 640	0.7	0.82	0.6	0.7	0.5	0.59	0.38	0.47
ECOVECTOR II LL 1030	1.39	1.66	1.2	1.46	1.0	1.22	0.8	0.97
ECOVECTOR II LL 1390	1.92	2.37	1.61	2.03	1.37	1.72	1.14	1.41

Model	Flow & return connections	Mains cable	Fused spur	Total Power Consumption		Water Capacity (Litres)	Max. current draw Amps	Sound Levels		Casting colour	Fan-only
				Low (Watts)	High (Watts)			Low (dBA)	High (dBA)		
ECOVECTOR III LL 640	15mm	1.5m	3A	16	31	0.29	0.25	31	33	white	yes
ECOVECTOR III LL 1030	15mm	1.5m	3A	26	44	0.58	0.45	32	34	white	yes
ECOVECTOR III LL 1390	15mm	1.5m	3A	41	67	0.83	0.60	34	36	white	yes

Heat outputs tested in accordance with BS4856 using entering water temperature and 340 l/h (75gph) flow rate. Sound levels measured at 1.5m.