

Ecovector® Low

Education | Healthcare | Places of worship | Leisure and sport | Office | Hospitality | Retail | Showroom | Industrial | Residential

Ecovector Low Level fan convectors provide warmth from the floor upwards and are more energy efficient and effective than radiators

The Ecovector can heat up a room more quickly than radiators, thereby reducing the amount of time your boiler or heat pump is running - making it extremely efficient and cost effective

Compatible with most types of wet central heating systems, functioning equally efficiently with conventional boilers, biomass technology or ground or air source heat pumps

Ideal for new and existing developments, due to ease of installation, the Ecovector is available in a range of models to suit varying room sizes and heat output requirements



As part of our commitment to continuous improvement Smith's Environmental Products may change the specifications of its products without prior notification or public announcement. All descriptions, illustrations, drawings and specifications in this publication present only general particulars and shall not form part of any contract. All dimensions are in mm unless otherwise stated. Please visit our website for the most up to date information.

Issue 007 | January 2025

+44 (0) 1245 324 900 | sales@smithsep.co.uk | SmithsEP.co.uk

 **Smith's**
A Swan Group Company

Product information

Finish

Front casing: zinc-coated steel.
Polyester powder-coated RAL 9010.
Side panels: polymer eggshell white.

Installation

Mounting bracket supplied.
Unit must be earthed.
Suitable for two-pipe central heating systems.
Minimum height above floor level 150mm.
Maximum height above floor level 500mm.

Commissioning

Check water is hot enough to activate the selectable low temperature cut-out thermostat.

Control

Rocker switch - low/off/high.
Built-in room thermostat.
Low temperature cut-out thermostat set to energise fan at approximately 35°C.

Specification

To specify state:
Low level hydronic fan convector in white.
As Smith's Ecovector Low LL1200, LL2000, LL2800.

Dimensions

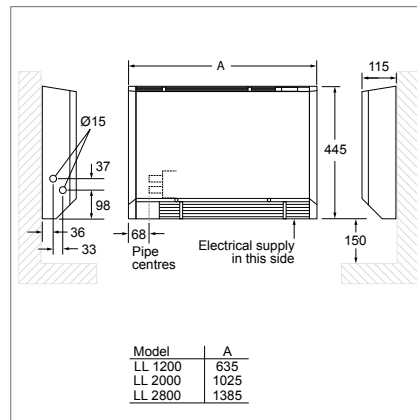

Ordering Guide

Model	Packed Wt (kg)	Product Codes
ECOVECTOR LL 1200	12	HPEV50001
ECOVECTOR LL 2000	17	HPEV50002
ECOVECTOR LL 2800	24	HPEV50003

Technical Data

Heat Output For other heat output data please visit our website

Model	Heat Output at 80°		Heat Output at 75°		Heat Output at 70°		Heat Output at 65°		Heat Output at 60°	
	Low (kW)	High (kW)	Low (kW)	High (kW)	Low (kW)	High (kW)	Low (kW)	High (kW)	Low (kW)	High (kW)
ECOVECTOR LL 1200	1.2	1.6	1.1	1.4	1.0	1.3	0.9	1.1	0.8	1.0
ECOVECTOR LL 2000	2.0	2.6	1.9	2.4	1.6	2.2	1.5	1.9	1.3	1.7
ECOVECTOR LL 2800	2.8	3.5	2.6	3.2	2.3	2.9	2.0	2.6	1.9	2.4

Model	Heat Output at 55°		Heat Output at 50°		Heat Output at 45°		Heat Output at 40°	
	Low (kW)	High (kW)	Low (kW)	High (kW)	Low (kW)	High (kW)	Low (kW)	High (kW)
ECOVECTOR LL 1200	0.7	0.8	0.6	0.7	0.5	0.6	0.4	0.5
ECOVECTOR LL 2000	1.2	1.6	1.0	1.3	0.9	1.1	0.7	0.8
ECOVECTOR LL 2800	1.9	2.1	1.3	1.8	1.2	1.5	1.0	1.2

Heat outputs tested in accordance with BS4856 using entering water temperature and 340 l/h (75gph) flow rate. Sound levels measured at 1.5m.

Model	Water Capacity (Litres)	Sound Levels		Casting colour	Fan-only	Flow & return connections	Mains cable	Transformer	Fused spur	Total Power Consumption	
		Low (dBA)	High (dBA)							Low (Watts)	High (Watts)
ECOVECTOR LL 1200	0.29	32	38	white	n/a	15mm	1.5m	n/a	3A	17	21
ECOVECTOR LL 2000	0.58	35	40	white	n/a	15mm	1.5m	n/a	3A	26	55
ECOVECTOR LL 2800	0.83	37	42	white	n/a	15mm	1.5m	n/a	3A	43	76

As part of our commitment to continuous improvement Smith's Environmental Products may change the specifications of its products without prior notification or public announcement. All descriptions, illustrations, drawings and specifications in this publication present only general particulars and shall not form part of any contract. All dimensions are in mm unless otherwise stated. Please visit our website for the most up to date information.