

Eco-Powerad®

Education | Healthcare | Places of worship | Leisure and sport | Office | Hospitality | Retail | Showroom | Residential

The Eco-Powerad is the fan convector of the future - energy efficient, responsive and suitable for installation within most wet central heating systems, driven by either boilers or low temperature renewable technology

Compact, with smooth lines to achieve visual simplicity, the Eco-Powerad also features low surface temperature casing for complete safety and possesses a very low operating sound - between 28 and 32 decibels

Compatible with most types of wet central heating systems, functioning equally efficiently with conventional boilers, biomass technology or ground or air source heat pumps

Supplied as standard in white but casing can be supplied in any colour



As part of our commitment to continuous improvement Smith's Environmental Products may change the specifications of its products without prior notification or public announcement. All descriptions, illustrations, drawings and specifications in this publication present only general particulars and shall not form part of any contract. All dimensions are in mm unless otherwise stated. Please visit our website for the most up to date information.

Issue 006 | January 2025

+44 (0) 1245 324 900 | sales@smithsep.co.uk | SmithsEP.co.uk

 **Smith's**
A Swan Group Company

Product information

Finish

Front casing: zinc coated steel.
Polyester powder-coated RAL 9010.

Installation

Mounting bracket supplied.
Unit must be earthed.
Suitable for two-pipe central heating systems.
Minimum height above floor level 150mm.
Maximum height above floor level 500mm.

Commissioning

Check water is hot enough to activate the low temperature cut-out thermostat.
Ensure system is balanced for even heat distribution.

Control

Low temperature cut-out thermostat, set to energise fan at approximately 35°C.
Suitable for thermostatic radiator valves (TRV) - not supplied.
Rocker switch - normal/low.

Specification

To specify state:
Wall mounted hydronic heat emitter with fan and low temperature cut-out.
As Smith's Eco-Powerad 500, 1000, 1500, 2000.

Dimensions

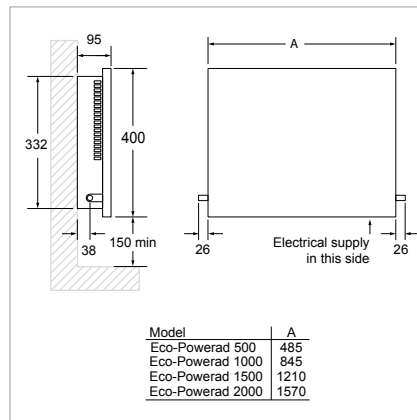

Ordering Guide

Model	Packed Wt (kg)	Product Codes
ECO-POWERAD 500	6	HPEP52001
ECO-POWERAD 1000	10	HPEP52002
ECO-POWERAD 1500	14	HPEP52003
ECO-POWERAD 2000	18	HPEP52004

Technical Data

Heat Output

Model	Heat Output at 80° (kW)	Heat Output at 75° (kW)	Heat Output at 70° (kW)	Heat Output at 65° (kW)	Heat Output at 60° (kW)	Heat Output at 55° (kW)	Heat Output at 50° (kW)	Heat Output at 45° (kW)	Heat Output at 40° (kW)
ECO-POWERAD LL 500	0.9	0.8	0.8	0.7	0.6	0.5	0.5	0.4	0.3
ECO-POWERAD LL 1000	2.4	2.1	1.8	1.6	1.4	1.2	1.0	0.8	0.7
ECO-POWERAD LL 1500	2.6	2.4	2.2	2.0	1.9	1.7	1.5	1.2	0.9
ECO-POWERAD LL 2000	3.9	3.5	3.2	2.8	2.5	2.2	2.0	1.7	1.3

Model	Flow & return connections	Mains cable	Transformer	Fused spur	Total Power Consumption (Watts)	Water Capacity (Litres)	Sound Levels (dBA)	Casting colour
ECO-POWERAD LL 500	15mm	2m	n/a	3A	15	0.17	28	white
ECO-POWERAD LL 1000	15mm	2m	n/a	3A	18	0.28	30	white
ECO-POWERAD LL 1500	15mm	2m	n/a	3A	33	0.44	31	white
ECO-POWERAD LL 2000	15mm	2m	n/a	3A	36	0.55	32	white

Outputs based on exiting water temperature. Heat outputs tested in accordance with BS4856 using exiting water temperature and 340 l/h (75gph) flow rate. Sound levels measured at 1.5m.