

Remote Control Switch

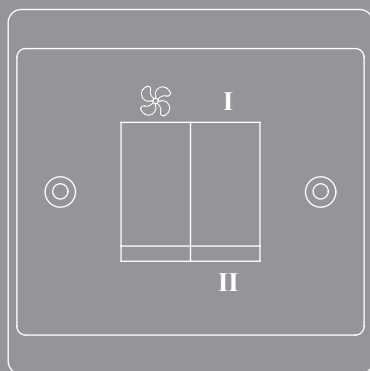

Installation and user manual



HYDRONIC RSCH REMOTE CONTROL SWITCH

This product is only for use with Smith's
SS3, 5, 7 and 9 Space Saver products

Contents

Introduction	2
Warning	2
Control Switch	3
Space Saver	4
Operation	5
Registering your product	6
Disposal	6
After sales and spares	7

Introduction

This accessory kit has been designed to easily convert a Smiths Space Saver from unit switching to remote switching providing normal, boost and off selection.

The accessory kit comes supplied with easy fit connectors and a 3m length of power cord.

Note: this remote control switch must only be used for operating one Space Saver unit.

Warning

Isolate the power supply to the Space Saver unit. Do not reconnect the power supply until the installation has been completed.

ALL ELECTRICAL INSTALLATIONS CONNECTIONS MUST COMPLY WITH BS7671, 1992 AND THE IEE REGULATIONS. CHECK THE VOLTAGE ON THE HEATER IS CORRECT FOR YOUR SUPPLY. IF IN DOUBT, CONSULT A QUALIFIED ELECTRICIAN.

This Product is not intended for use by persons (including children) with reduced physical, sensory or mental capabilities, or lack of experience and knowledge, unless they have been given supervision or instruction concerning use of the product by a person responsible for their safety. Children should be supervised to ensure that they do not play with the product.

Control Switch

1. Locate a suitable position adjacent to the Space Saver unit that will allow connection to the 3 metre power cord (supplied). Note: This must be away from water or high humidity.
2. Fix the switch mounting box to suit the required type of installation. Connect the power cord to the remote switch as shown below. Note access may be required to the fan convector by removing the lower cupboard shelf directly above heater.
3. Run the power cord via the prepared route to the Space Saver unit.

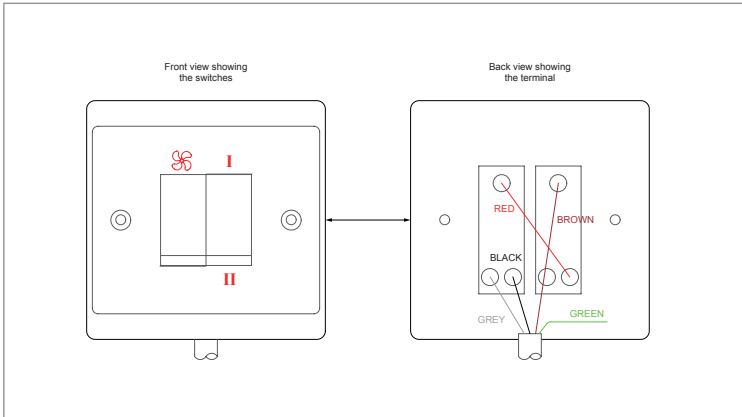

Space Saver

Important: If the Space Saver unit is already installed please disconnect or isolate from the electrical supply.

1. Remove the lid fixing screws and remove the lid of the Space Saver unit
2. Push the power cord complete with cable gland from the control switch into the Space Saver chassis in the hole provided adjacent to the earth terminal (see diagram). Ensure there is approx 100mm of cable entering the unit, fit and tighten the locking nut and tighten the outer nut on the cable gland to securely fasten the power cord.

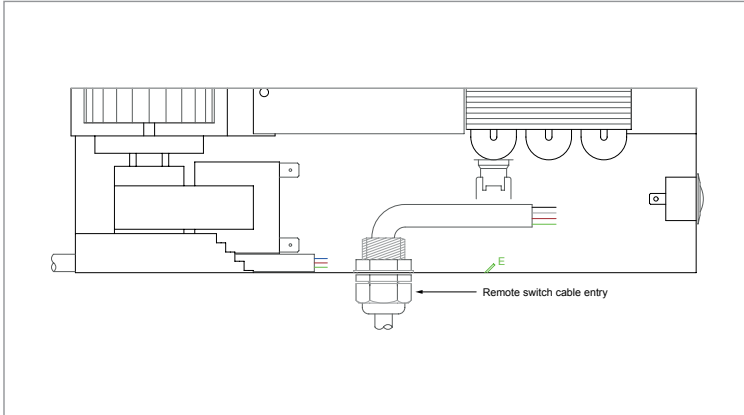

3. Remove and discard both the red and yellow wires between the lower (fan speed) switch and the fan.
4. Disconnect the brown wire from the lower (fan speed) and slide the sleeving onto the wire. Connect the 2 brown wires together and slide the sleeving over the joint, carefully fit a cable tie to each end of the sleeving to secure.
5. Fit the grey wire to the top right hand side motor terminal and fit the black wire to the top left hand side motor terminal. See diagram below.

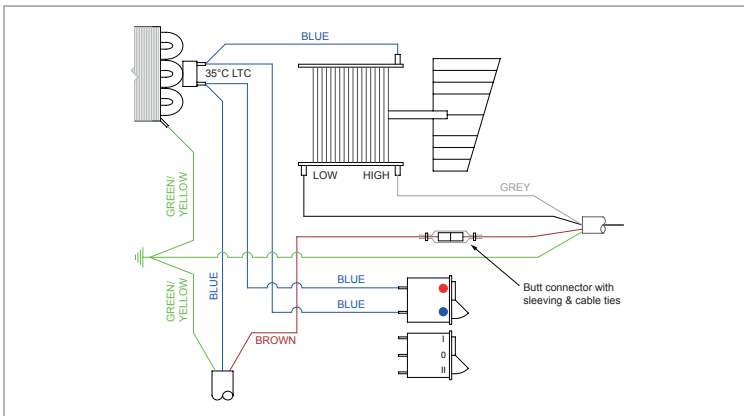

6. Next remove the earth wire (yellow / green) from the chassis tab, fit the earth wire to connector on the incoming lead and securely fix back into place on the chassis earth tab. See diagram below.

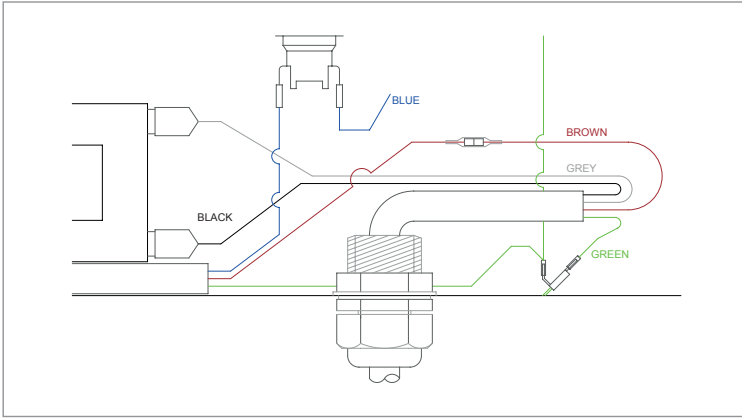

7. Ensure wires are not snagged, refit lid, refit the screws and tighten.
8. Fit the Space saver unit back into place and reinstate the electrical supply.

Operation

1. Fitting a remote control switch makes the integral fan speed control switch inoperative.
2. The Summer/Winter switch operation (top switch) remains active and should be used to select the desired mode.
3. Set the remote control switch to either or and the left hand Red / Blue dot switch the red (on).
4. Providing the central heating system is switched on and there is hot water within the system the fan will run.

Registering your product

Thank you for purchasing a Smith's product. It has been designed and manufactured to the highest quality standards to ensure it gives you efficient and trouble-free service for many years. We are committed to achieving the highest standards and our faith is supported by a free parts and labour guarantee with every product.

For more information on the warranty period for this product please visit our website smithsep.co.uk/product-registration/

This gives you the peace of mind that in the unlikely event of product failure, we will repair or replace the product completely free of charge providing the product has been installed, used and maintained in accordance with the instructions. Your statutory rights are not affected by this warranty.

It is important to register as soon as possible online at: smithsep.co.uk/product-registration/. This will ensure you will receive prompt and efficient service if your product requires attention within the warranty period. If you do not register your product, you will be required to produce proof of purchase prior to receiving service.

For more details please visit our website: SmithsEP.co.uk

SCAN HERE TO REGISTER
YOUR PRODUCT

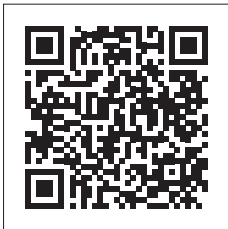

Disposal

As part of the policy of continuous product improvement, Smith's Environmental Products LTD reserves the right to alter specification without prior notice.

Products with this symbol (crossed out wheellie bin) cannot be disposed as household waste. Old electrical and electronic equipment must be recycled at a facility capable of handling these products and their waste by-products. If you are purchasing replacement equipment your retailer may offer a 'take back' scheme, or will be able to give details of the nearest approved authorised treatment facility. Proper recycling and waste disposal will help conserve resources whilst preventing detrimental effects on our health and the environment.

WEEE Registered Code: WEE/ED0093VW



Approved CQS ISO
9001:2015



ISO 14001
Certificate No. 2022002028

After sales and spares

If you experience any problems with the use of your product, please contact our after-sales office +44 (0) 1245 324560.

For product information, customer services or sales support call us on +44 (0) 1245 324900

For the Republic of Ireland, contact MT Agencies on 01 864 3363

Sales: sales@SmithsEP.co.uk

General information: info@SmithsEP.co.uk

Smith's Environmental Products Ltd
Blackall Industrial Estate, South Woodham Ferrers,
Chelmsford, Essex CM3 5UW

SmithsEP.co.uk

[@SmithsEP_UK](https://www.instagram.com/SmithsEP_UK)

[#ThinkSmiths](https://www.facebook.com/ThinkSmiths)



Happy to help

Smith's Environmental Products Ltd is one of the leading manufacturers of heating and cooling products in the UK. We are committed to achieving the highest standards and our faith is supported by a free parts and labour guarantee with every product (see our website for more information). Our customer service is second to none and we are happy to offer any help and guidance that you might need.

Stockists

All products are available nationally from Builders' Merchants, Plumbers' Merchants, Heating Equipment Distributors and Kitchen Equipment Distributors. In the event of difficulty, please contact us or visit our website SmithsEP.co.uk for details of your nearest stockist.

Information and advice

Full technical specifications and list prices is available to download from our website or in hard copy from our office. Also available on our website are price lists, individual product data sheets, installation & user guides, where to buy, who to contact and a media centre.

Alternatively contact our office 9.00am to 5.00pm Monday to Friday.

As part our commitment to continuous improvement Smith's Environmental Products may change the specifications of its products without prior notification or public announcement. All descriptions, illustrations, drawings and specifications in this publication present only general particulars and shall not form part of any contract. All dimensions are in mm unless otherwise stated. Please visit the website for the most up to date information.

**To view the full product information
download the datasheet at:
www.SmithsEP.co.uk**

For product information, customer services or sales support call us on **+44 (0) 1245 324900**

For the Republic of Ireland, contact MT Agencies on 01 864 3363

Sales: sales@SmithsEP.co.uk

General information: info@SmithsEP.co.uk

Smith's Environmental Products Ltd
Blackall Industrial Estate, South Woodham Ferrers,
Chelmsford, Essex CM3 5UW

SmithsEP.co.uk

[@SmithsEP_UK](https://twitter.com/SmithsEP_UK)

[#ThinkSmiths](https://www.facebook.com/ThinkSmiths)

Issue 002 | 04-1158 | November 2024