

Sterling

Education | Healthcare | Places of worship | Leisure and sport | Office | Hospitality | Retail | Showroom | Industrial | Residential

The Sterling fan-assisted electric heater is a great low cost solution providing effective and dependable heating for both small and large commercial areas, fitted unobtrusively above head height

It has been designed for rooms with limited lower wall space, such as shops and libraries



As part our commitment to continuous improvement Smith's Environmental Products may change the specifications of its products without prior notification or public announcement. All descriptions, illustrations, drawings and specifications in this publication present only general particulars and shall not form part of any contract. All dimensions are in mm unless otherwise stated. Please visit our website for the most up to date information.

Issue 005 | January 2025

+44 (0) 1245 324 900 | sales@smithsep.co.uk | SmithsEP.co.uk

 **Smith's**
A Swan Group Company

Product information

Finish

Outer casing 0.9mm zinc-coated steel.
Polyester powder-coated white.
Side panels: Polymer - white.

Installation

Recommended installation height 2.3m to underside.
Not suitable for bathrooms and other high humidity areas.
Angled mounting (optional).
13 amp fused spur required.
Unit must be earthed.

Controls

Rocker switches for fan and element - fan only 1kW/2kW/3kW.
Wireless temperature control featuring comfort, set back and run back timer (battery operated) supplied.
Overheat protection: thermal cut-out.
Manual reset procedure: switch power off at mains, wait 20 minutes, switch power on.

Specification

To specify state:
3-speed electric fan-assisted heater in white polyester coated 0.9mm zinc-coated steel body with built in room thermostat.
As Smith's Sterling.

Dimensions

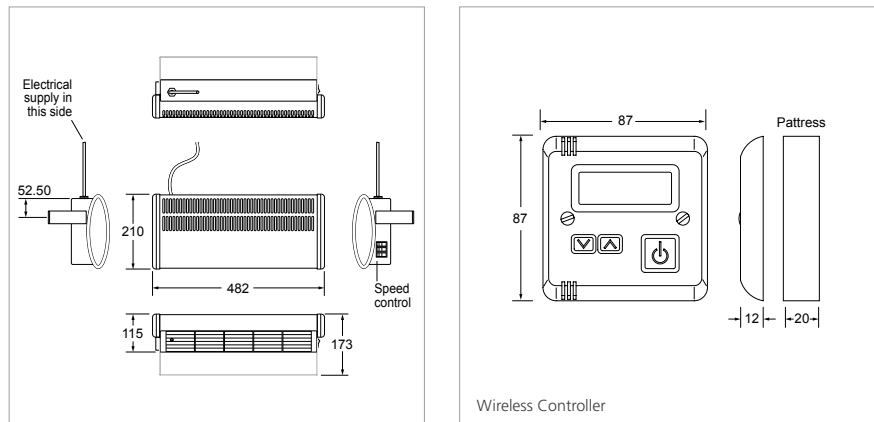

Ordering Guide

Model	Packed Wt (kg)	Product Codes
STERLING E 3KW	4	HPST51012

Technical Data

Heat output

Model	Heat Output (kW)	Fused spur	Total Power Consumption (kW)	Sound Levels (dBA)	Casting colour	Fan-only
STERLING E 3KW	1kW/2kW/3kW	13A	1kW/2kW/3kW	39	white	•

Sound levels measured at 1.5m with the product installed at 2.2m high