



SKYLINE® E 4kW

INSTALLATION & USER GUIDE

Jan 2018 onwards SLVT Wireless Control



USER INFORMATION

This heater must be used with the supplied SLVT wireless controller. It will not work without it.

This appliance can be used by children aged from 8 years and above and persons with reduced physical, sensory or mental capabilities or lack of experience and knowledge if they have been given supervision or instruction concerning use of the appliance. Cleaning and user maintenance shall not be made by children without supervision.

THIS HEATING APPLIANCE MUST NOT BE USED IN BATHROOMS OR SIMILAR HIGH HUMIDITY AREAS

This heating appliance is intended for use as a down draught air heater and can be mounted directly onto the ceiling or fitted into a 600 mm X 600 mm suspended ceiling tile frame. It is to be mounted with the underside between 2.5 and 3.0 metres from floor level. If exceeding 3 metres there will be a reduction in performance. **THIS HEATER MUST BE USED WITH THE SLVT CONTROLLER (SUPPLIED). IT WILL NOT WORK WITHOUT IT.**

INSTALLATION.

Preparation.

- a) Ensure the mounting surface is capable of supporting this heating appliance and that the area can provide the installation clearances shown in diagram 1.
- b) If installing this heating appliance into a false or suspended ceiling, suitable suspension chains or rods (6 mm dia., threaded) will be required for attachment from the top of the heater appliance to the rigid or solid surface above the mounting area. When using this installation technique, it is recommended the four fixing points at the top corners of the heater appliance be used to minimise movement.
- c) An installation point for the heater appliance control switch (fig 1) must be selected. The area must be free from moisture and no higher than 2 metres from the floor. An electrical cable is required from the power supply to the control switch and from the control switch to the heater appliance (see under Electrical Connections).
- d) Remove the facia and fixing screws. Store these in a safe place until required.
- e) Remove the screws retaining the side panel marked Electrical Connections and take out the panel. Store these until required.

To mount the heater appliance direct to the ceiling.

A surface mounting kit is available as an accessory. This kit provides a 135 mm skirt between the facia and the ceiling.

1. Drill six holes in the ceiling to match 6 (3 per side) of the 14 holes available in diagram.
Note: The installation clearances given must be kept outside the broken lines shown. The lines represent the outer edges of the facia panel.
2. Plug the drilled holes according to the ceiling type and construction material.
3. Secure the heater appliance to the ceiling using screws suitable for the purpose.
4. Refer to the section under Electrical Connections.
5. Replace and secure the panel marked Electrical Connections.
6. Replace the facia and secure with all the original screw

To mount the heater appliance via suspension rods or chains.

A ceiling tile spacer is available as an accessory. This kit allows the fascia to protrude 85 mm beneath the finished ceiling tile, matching the profile of the Skyline® CT18 hydronic model. A Surface mounting kit is also available which provides a complete four sided trim when fitted to a solid ceiling.

7. If the mounting area is to align with a false or suspended ceiling panel, then the holes must be centred to the panel.
8. Cut the suspension chains or rods to the required length for the installation. Secure to the mounting surface.
9. Secure the lower ends of the chains or rods to the top four corners of the heater appliance. Adjust the lengths of the chains or rods as necessary to ensure the heater appliance is true and level.
10. Refer to the section under Electrical Connections.
11. Replace and secure the panel marked Electrical Connections.
12. Replace the fascia and ensure it is secured with all the original screws.

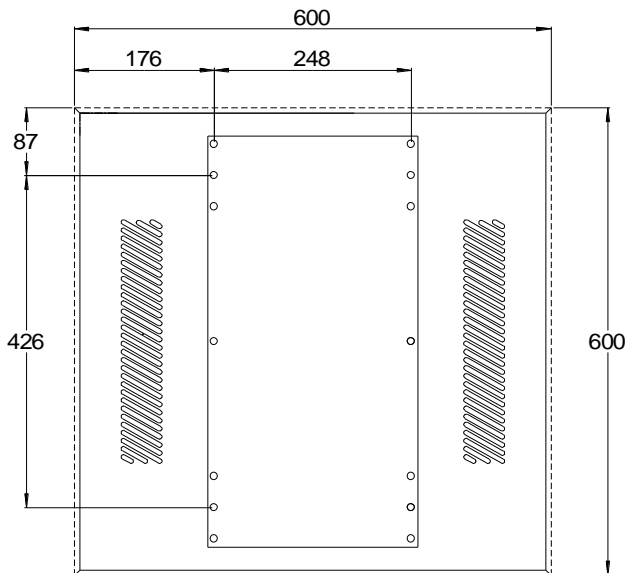

Installation clearance necessary is 600mm on all four sides outside the broken line shown.

DIAGRAM 1

All dimensions in mm.

CT4E GRILLE FIXING INSTRUCTIONS

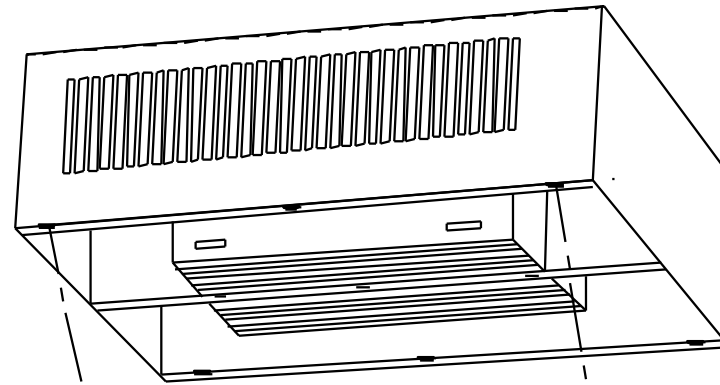

Align grille panel to heater unit and secure in position with all 9 screws provided. Ensure the grille panel is flat and free from distortions

DO NOT DISTURB THE INNER COMPONENTS OF THE HEATER UNIT.

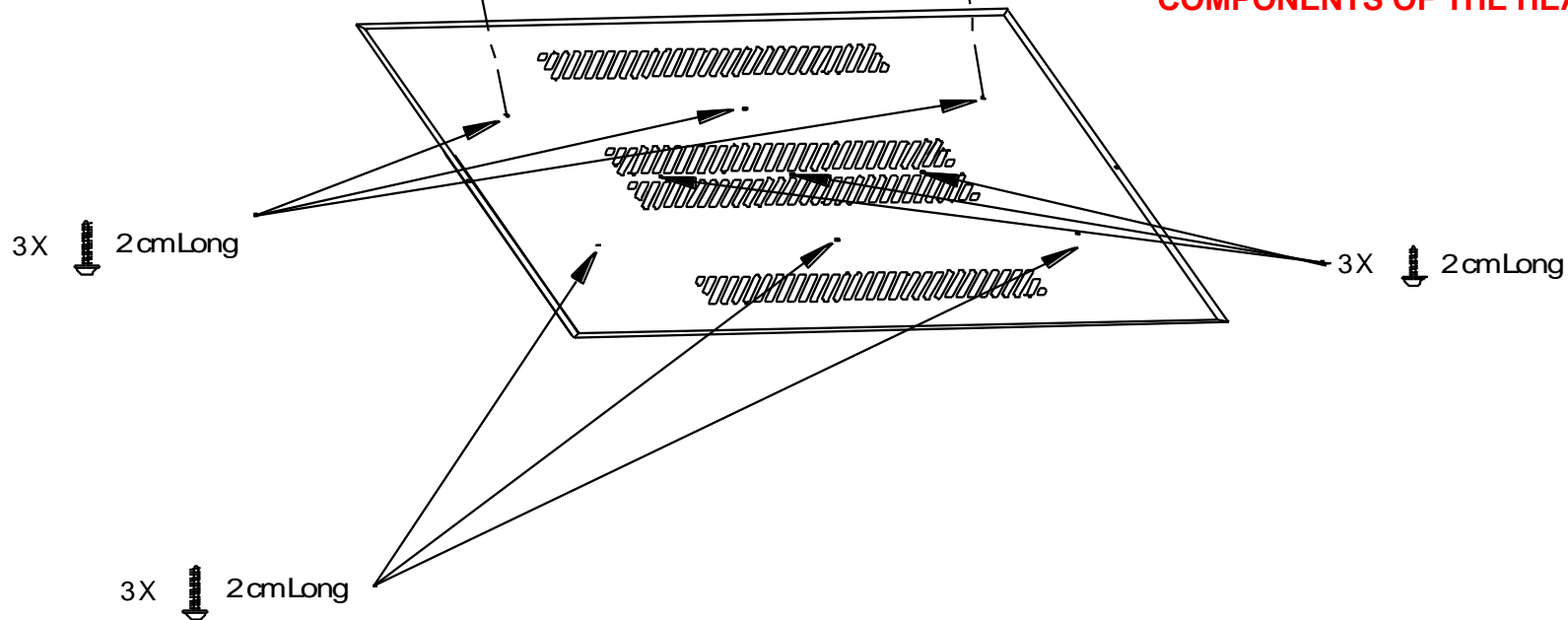
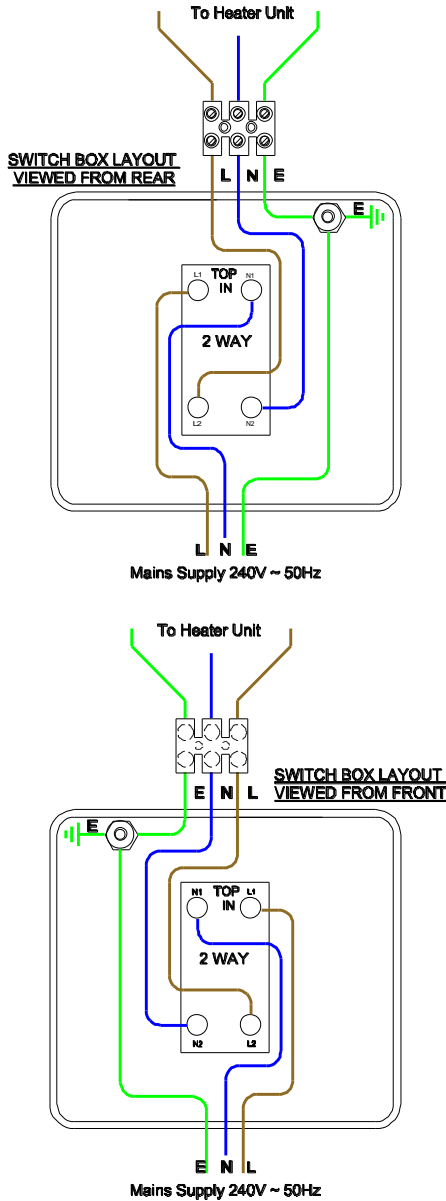

Fig 1



The electrical supply to these units should be via 2.5mm² single strand 3 core cable via a switch fused isolator fused at 20Amps.

All electrical connections and installations must comply with BS7671 1992, and the I.E.E. regulations. Check the voltage stated on the heater appliance is correct for your supply. If in doubt, consult a qualified electrician.

Electrical Connections.

Place and secure a 3 core **2.5mm² single strand** interconnecting cable from the heater appliance location to that of the control switch.

Pass the cable through the heater appliance cable entry facility.

Ensure there is sufficient cable to pass under the cable grip and reach the terminal block / earth pillar area inside the heater appliance.

Control Switch.

Remove the two screws retaining the switch front panel and lift it off. Remove the two screws retaining the inner frame and switch from the patress box. Lift out the frame and switch.

Prepare the patress box for cable entry by selecting the top, bottom or rear facility for the interconnecting cable and the mains electrical supply cable. Secure the patress box to the mounting surface and feed sufficient cable through the selected entry point.

With the three cores of the interconnecting cable, connect the control switch to the heater appliance as shown in the wiring diagram.

Connect the mains electrical supply cable (3 core, single strand 2.5mm²) via a switched fused isolator, fused at 20A to the switch panel as shown in the wiring diagram.

Do not energise the supply until the panels described have been returned and secured.

Pairing with the SLVT wireless controller

This unit must be paired with the SLVT wireless controller before it will operate. See separate instructions supplied with the controller.

Note: the heater WILL NOT operate unless it is used and paired with the controller

Unit Operation.

The wall mounted control switch has 2 positions Off (no fans no heat) and On (fans and 4Kw heat)

Smith's Environmental Products Ltd
Units 1 & 2 Blackall Industrial Estate
Hamberts Road
South Woodham Ferrers
Chelmsford
Essex
CM3 5UW

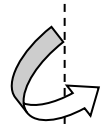

please fold along here

Please
affix
stamp
here



Guarantee Statement

Thank you for purchasing a Smith's heater.

It has been designed and manufactured to the highest quality standards to ensure it gives you efficient and trouble-free service for many years.

To back up our commitment, included with your product is a **free five year parts and labour guarantee.**

This gives you peace of mind that in the unlikely event of the product failing within the first five years, we will repair or replace the product completely free of charge provided the product has been installed, used and maintained in accordance with the instructions.

It is important to register within 7 days. This will ensure you receive a prompt and efficient service, if your product requires attention within the guarantee period. If you do not register your product, you will be required to produce a proof of purchase prior to receiving this service.

If you experience any problems with the use of your product, please contact our **after-sales office** on 01245 324560.

Smith's Environmental Products Ltd manufactures a complete range of heaters for domestic and commercial applications.

If you require any further information, please contact us on **01245 324900** or visit our website at **www.SmithsEP.co.uk**

Your statutory rights are not affected by this guarantee.

Please pull this Registration card from the booklet and fill in all parts and return.

User Details

User Name Mr/Mrs/Miss/Ms/Other

Initials Surname

Address

.....

..... Post Code:

Telephone:

Product & Model installed (e.g. Space Saver SS5)

.....

Room Installed (e.g. Kitchen):

Your details will only be held by Smiths Environmental Products Ltd and used solely to provide customer services and product information. If you do not wish to be contacted, please put an x in the box.

Installer Details

Company name:

Principal contact: Mr/Mrs/Miss/Ms/Other:

Initials: Surname:

Address:

.....

..... Post Code:

Telephone:

Date of installation/...../.....

Room Installed (e.g. Kitchen):

Your details will only be held by Smiths Environmental Products Ltd and used solely to provide customer services and product information. If you do not wish to be contacted, please put an x in the box.

**Guarantee Registration Card
& Customer Satisfaction Survey**

Dear Customer

We hope our product suits all your requirements; it would help us immensely if you could find the time to fill in this form, your response will help us maintain the quality standards we all expect in today's climate.

Customer name _____ Date ____/____/____

Email Address _____@_____

Product Name _____

Tick as appropriate

	V Good	Good	Fair	Poor
Product	<input type="checkbox"/>	<input type="checkbox"/>	<input type="checkbox"/>	<input type="checkbox"/>
Delivery	<input type="checkbox"/>	<input type="checkbox"/>	<input type="checkbox"/>	<input type="checkbox"/>
Sales & Ordering	<input type="checkbox"/>	<input type="checkbox"/>	<input type="checkbox"/>	<input type="checkbox"/>
Response to any problems	<input type="checkbox"/>	<input type="checkbox"/>	<input type="checkbox"/>	<input type="checkbox"/>

Comments
.....
.....
.....

Thank you for your time to fill in this survey, the response will help us to serve your needs more effectively. Please return by fax to 01245324422.

Quality Control Manager: Ron Brown ron.brown@smithsep.co.uk

Products with this symbol (crossed out wheellie bin) cannot be disposed as household waste. Old electrical and electronic equipment must be recycled at a facility capable of handling these products and their waste by-products. If you are purchasing replacement equipment your retailer may offer a 'take back' scheme, or will be able to give details of the nearest approved authorised treatment facility. Proper recycling and waste disposal will help conserve resources whilst preventing detrimental effects on our health and the environment.

WEEE Registered Code : WEE/ED0093VW

This appliance is not intended for use by persons (including children) with reduced physical, sensory or mental capabilities, or lack of experience and knowledge, unless they have been given supervision or instruction concerning use of the appliance by a person responsible for their safety.

Children should be supervised to ensure that they do not play with the appliance.



ISO 9001: 2015



Smith's Environmental Products Ltd

Blackall Industrial Estate, South Woodham Ferrers, Chelmsford, Essex, CM3 5UW
Tel: 01245 324900 Fax: 01245 324422

Sales: sales@SmithsEP.co.uk General Information E-mail: info@SmithsEP.co.uk Web: www.SmithsEP.co.uk

For Ireland, contact MT Agencies (Ireland) Ltd on Tel: 00353 1 844 3212

As part of the policy of continuous product improvement,
Smith's Environmental Products Ltd reserves the right to alter specification without prior notice.