

Caspian Model Transformer Tapping's					
Line Speed	Caspian 60	Caspian 90	Caspian 120		
	Type 03/04	Type 06/07	Type 10	Type 11	Type 12
LSL	90	90	90	100	110
MSL	100	100	110	120	130
HSL	110	110	120	130	140



Products with this symbol (crossed out wheelie bin) cannot be disposed as household waste. Old electrical and electronic equipment must be recycled at a facility capable of handling these products and their waste by-products. If you are purchasing replacement equipment your retailer may offer a 'take back' scheme, or will be able to give details of the nearest approved authorised treatment facility. Proper recycling and waste disposal will help conserve resources whilst preventing detrimental effects on our health and the environment.

WEEE Registered Code : WEE/ED0093VW



ISO 9001
Registered Firm



Smith's Environmental Products Ltd

Blackall Industrial Estate, South Woodham Ferrers, Chelmsford, Essex, CM3 5UW
Tel: 01245 324900 Fax: 01245 324422

Sales: sales@SmithsEP.co.uk General Information E-mail: info@SmithsEP.co.uk Web: www.SmithsEP.co.uk

For Ireland (Republic & Northern), contact MT Agencies on 00 353 1 864 3363

In light of our policy of continuous development Smith's Environmental Products Ltd reserve the right to alter specifications without prior notice.

TCAS T1-T2 Kit

Thermostat Control T1 & Automatic Speed Change T2

Installation and User Guide

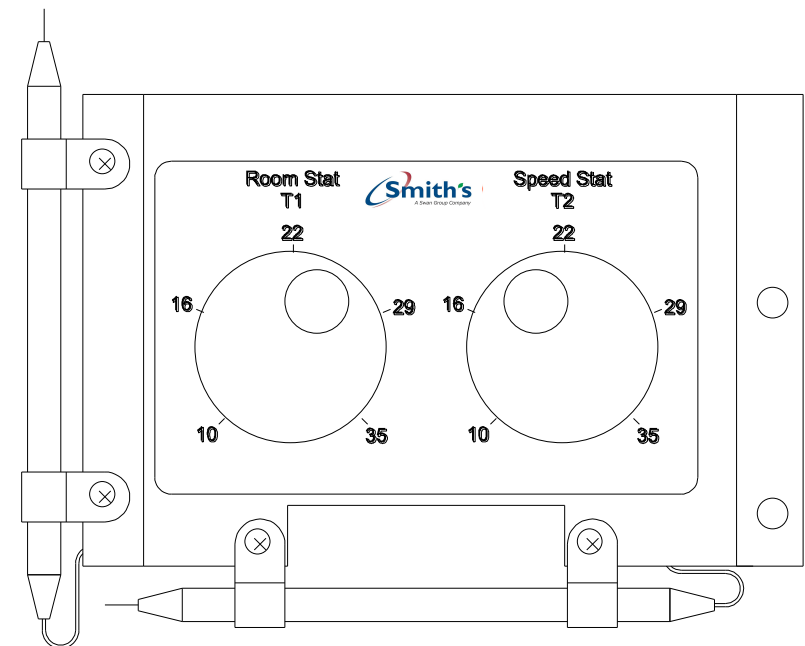

Introduction

This product is only for use with a Smiths Caspian Low Level (LL) Fan Convecter. The TCAS 12 kit will operate automatically under normal running conditions.

An adjustable room thermostat (T1) located in the incoming air provides constant room temperature control. To provide rapid warm up the automatic speed change thermostat (T2) switches fan(s) between 2 selected speeds at any predetermined temperature setting (generally a difference of between 3 – 6 degrees lower than that of T1 is used). The constant temperature control is then maintained by the T1 room thermostat.

Warning:

Isolate the power supply to the Caspian unit. **Do not** reconnect the power supply until the installation has been completed.

ALL ELECTRICAL INSTALLATIONS CONNECTIONS MUST COMPLY WITH BS7671, 1992 AND THE IEE REGULATIONS. CHECK THE VOLTAGE ON THE HEATER IS CORRECT FOR YOUR SUPPLY. IF IN DOUBT, CONSULT A QUALIFIED ELECTRICIAN.

Please note the guarantee may be invalidated if this product is not installed and used in accordance with these instructions.

Installation

1. Remove the front access cover of the Caspian.
2. Unscrew and remove the inner electrical panel and add the spacer (see figure 1). Fix the inner electrical panel back into the unit.
3. Attach T1T2 accessory panel to the side of the unit below the electrical panel with the screws provided (see figure 1).

Figure 1

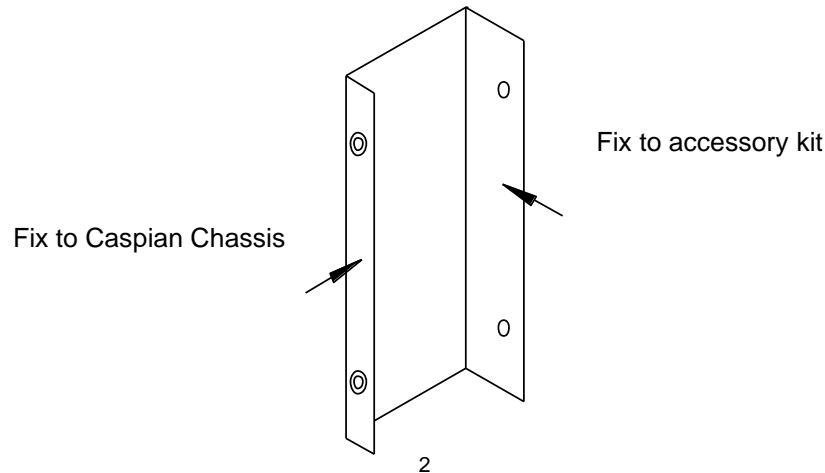

4. Remove all the wires from the fan speed switch, trace the wires down and remove opposite end.
5. Remove and discard the brown wire between the transformer terminal 2401v and the single power switch (see wiring diagram A).

Wiring diagram A

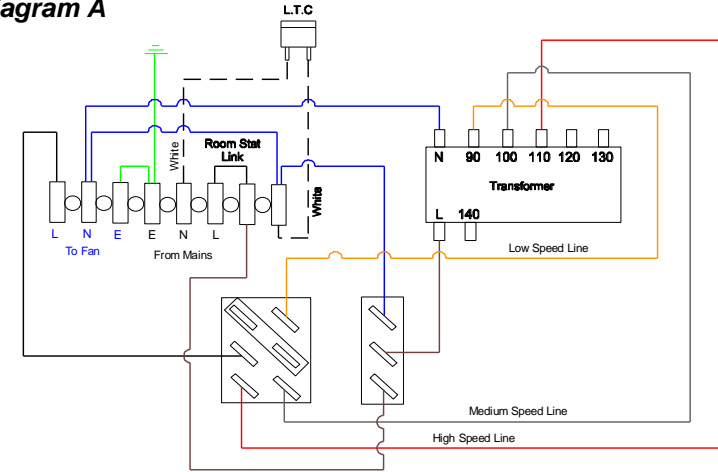

6. Connect the short brown wire from the TCAS T12 kit to the transformer terminal 240v (see wiring diagram B).
7. Connect the long brown wire from the TCAS T12 kit to the power switch (see wiring diagram B).
8. Connect the black wire from the TCAS T12 kit into the top left side of the terminal block (see wiring diagram B)
9. Trace the blue wire from the single power switch to the terminal block, Remove and reposition in the "N" mains terminal. (See wiring diagram B)

Wiring diagram B

