

IMPORTANT

1. The appliance is not to be used by children or persons with reduced physical, sensory or mental capabilities, or lack of experience and knowledge, unless they have been given supervision or instruction
2. Children should not be permitted to play with the appliance
3. Ensure that the fan is switched off from the supply mains before removing the guard
4. Any specifications with regards to dimensions of space required for the appliance to operate effectively



Products with this symbol (crossed out wheeled bin) cannot be disposed as household waste. Old electrical and electronic equipment must be recycled at a facility capable of handling these products and their waste by-products. If you are purchasing replacement equipment your retailer may offer a 'take back' scheme, or will be able to give details of the nearest approved authorised treatment facility. Proper recycling and waste disposal will help conserve resources whilst preventing detrimental effects on our health and the environment.

WEEE Registered Code: WEE/ED0093VW



Smith's Environmental Products Ltd

Blackall Industrial Estate, South Woodham Ferrers, Chelmsford, Essex, CM3 5UW
Tel: 01245 324900 Fax: 01245 324422

Sales: sales@SmithsEP.co.uk General Information E-mail: info@SmithsEP.co.uk Web: www.SmithsEP.co.uk

For Ireland, contact MT Agencies (Ireland) Ltd on Tel: 00353 1 844 3212

As part of the policy of continuous product improvement,
Smith's Environmental Products Ltd reserves the right to alter specification without prior notice.



Versatile, energy efficient heating

Eco-Powerad®

Models

Eco-Powerad 500, Eco-Powerad 1000,
Eco-Powerad 1500 & Eco-Powerad 2000

INSTALLATION & USER GUIDE

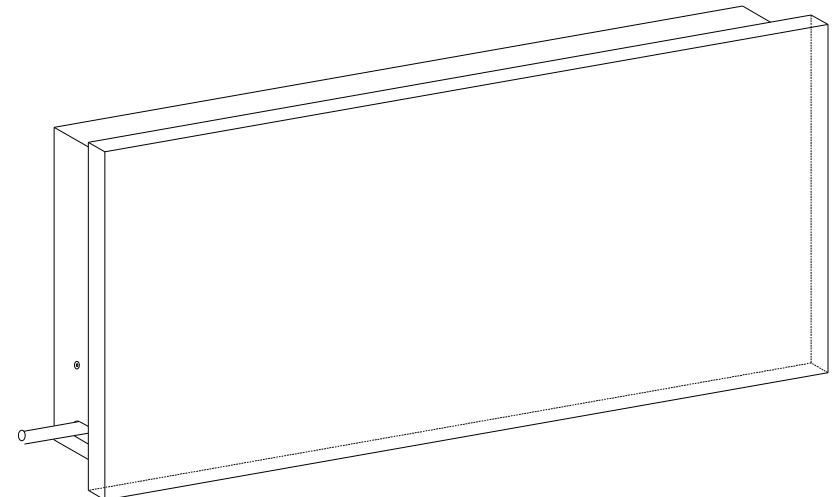

INTRODUCTION

In the event of items missing or visible damage please contact us on 01245 324560.

This heating appliance is intended for mounting on a wall at low level. The minimum recommended installation height is 150cm (6 inches) from the floor. There is no clearance required on either side of the heater.

This heater must not be used in bathrooms or other high humidity areas. Eco-Powerad® units are designed for use on two-pipe pumped central heating systems and are also suitable with use in a system where hot water is generated from renewable sources. This product is not suitable for one-pipe heating systems. Pipe connections are 15mm.

We recommend the use of Thermostatic Radiator Valves (TRV'S) to connect the unit to the heating system and to control the room temperature. Please note, only reversible angle valves are suitable. Connections into each end of radiator are via 15mm copper tube. Not ½ female iron. Make sure the male iron fitting supplied with the rad valves are removed, so connections can be made via the compression fitting.

Alternately this heater can be used in conjunction with a wall mounted remote room thermostat. Refer to the manufacturers instructions supplied with the thermostat.

Eco-Powerad® is classified as a fixed appliance and electrical connection should be via a double pole 3A fused spur.

The fused spur must not be directly above the heater but should be accessible after completion of the installation.

If the pre-wired mains cable is damaged, it must be replaced by the manufacturer, its service agent or similarly qualified persons. The appliance must be earthed.

To avoid possibility of vibration, this product must be installed on a flat, even surface.

To conform with building regulations part I (part j in Scotland) a remote room thermostat can be used in conjunction with this heater. Refer manufactures instructions supplied with the thermostat.

Please note the guarantee may be invalidated if this product is not installed and used in accordance with this guide.

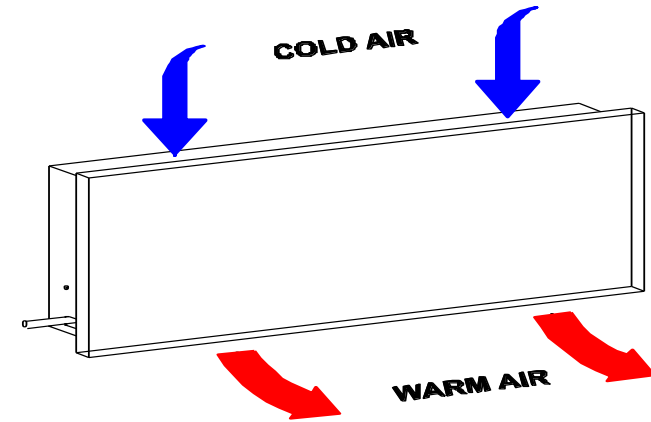

Heating

Ensure your central heating is ON and set the Theromstatic Radiator Valve (TRV) or room thermostat (if fitted) to the required position . Set the fan speed switch to the desired position (I or II). Providing the water temperature in the system is more than 38°C and the thermostat controlling your central heating system is calling for heat, the heater will switch on.

Moving the switch to (0) will turn off the heater.

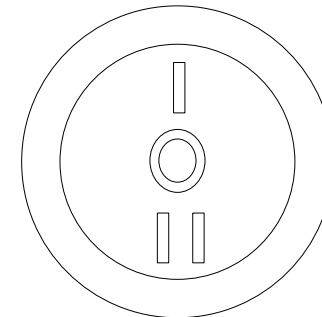

FAULT FINDING

Fan does not run on any switch setting

- Check the power source is switched ON
- Check fuse in the fused spur
- Check wiring connections at the fused spur
- Check the central heating is switched on and the TRV or room thermostat (if fitted) is calling for heat.

No heat output on settings I or II

- Check the power supply is switched ON
- Ensure the TRV or room thermostat (if fitted) is calling for heat
- Balance the central heating system if installed on the same circuit as panel radiators and increase the circulating pump speed if required.

In the event of difficulty please contact us on 01245 324560. It will be more helpful if you do not remove the product from the central heating system.

We would be most grateful if you would leave this installation & operation guide and the guarantee registration card with the owner of the property.

USER GUIDE

Your product is covered by a free 5-year parts and labour guarantee; please complete and return the Guarantee Registration Card to us as soon as possible to ensure that should you require assistance, we can help you quickly and efficiently.

Your Eco-Powerad® heater is designed to operate as part of your central heating system in the same way as a panel radiator. It will switch on and off automatically with you central heating system.

Heat from your central heating system passes through a heat exchanger transferring its heat to the aluminium fins, room air is drawn in the top grille and heated as it passes through the heat exchanger before being gently expelled back into the room at floor level.

MOUNTING THE UNIT

Remove the lower mounting bracket/air deflector strip and the EZ hanger from the back of the unit.

Attach lower mounting bracket/ air deflector strip to the lower rear edge of the unit as shown.

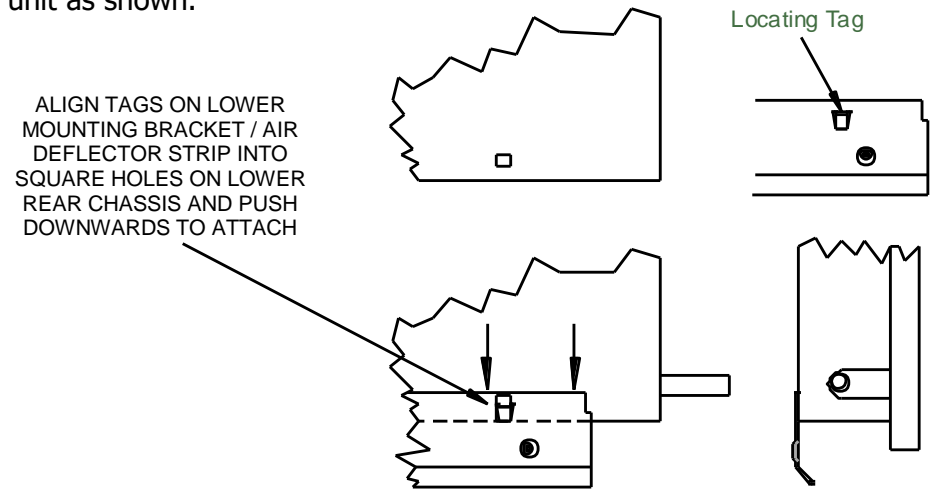

Fix the EZ easy hanger to the wall, using suitable fixings, position the heater on the EZ hanger and mark the fixing holes of the lower mounting bracket/air deflector.

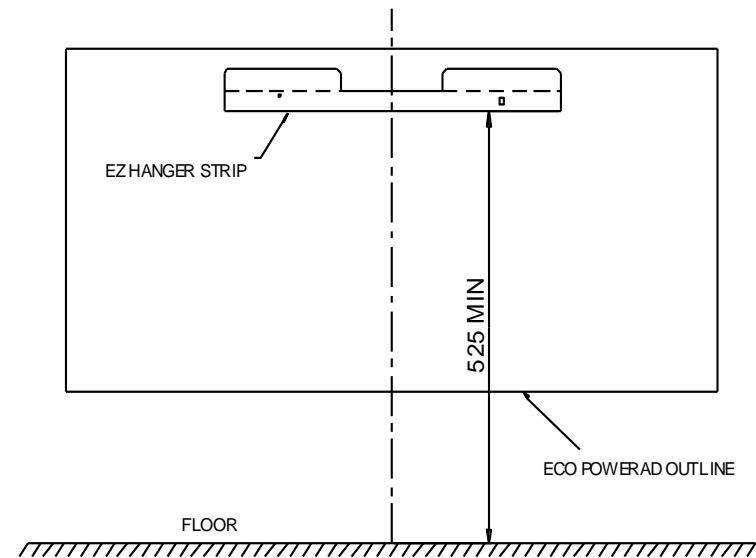

Position the unit on the EZ bracket and fix the lower mounting bracket/air deflector to the wall with suitable fixings (not supplied). See diagram overleaf.

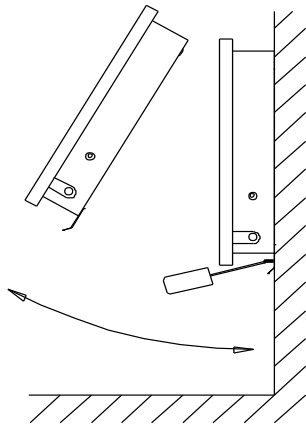

PIPE WORK

This product should be connected to the system flow and return pipes via the use of TRV's Thermostatic Radiator Valves.

Connect the heating system flow and return pipes to the heater pipe-work ends on either side of unit using (TRV's) Thermostatic Radiator valves (not supplied - refer to TRV manufacturers instructions).

Take care not to stress or overtighten fittings as this could damage the unit pipework. (Note- If the heater is being wired in conjunction with a wall mounted remote room thermostat it is recommended that isolating valves are fitted to the flow and return pipes in place of TRV's)

Check for water leaks. Remove any trapped air from the system via the vent valve via the access holes in either side of the unit (if the flow is connected to the right hand side then the opposite side vent must be bled and vice versa.) Do not over tighten the air vent

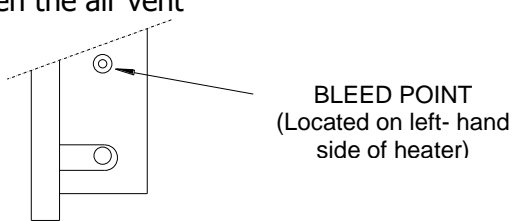

ELECTRICAL CONNECTION

ALL ELECTRICAL INSTALLATIONS CONNECTIONS MUST COMPLY WITH BS7671, 1992 AND THE IEE REGULATIONS. CHECK THE VOLTAGE ON THE HEATER IS CORRECT FOR YOUR SUPPLY. IF IN DOUBT, CONSULT A QUALIFIED ELECTRICIAN.

If the pre-wired mains cable is damaged, it must be replaced by the manufacturer, its service agent or similarly qualified persons.

Isolate the supply and connect the heater three core mains lead to the fused spur (3A) in accordance with the instructions provided on the mains lead label. (The supply wire which is coloured green or green and yellow must be connected to the terminal marked **E** on the appliance, the supply wire which is coloured black or blue must be connected to the terminal marked **N** on the appliance and the supply wire which is coloured red or brown must be connected to the terminal marked **L** on the appliance).

The fused spur must not be directly above the heater but should be accessible after completion of the installation.

COMMISSIONING

This heater is equipped with a low temperature cut out thermostat which requires the water in the heating system to be at least 38°C before the fans will run.

Turn on the electrical supply at the fused spur, switch on the central heating system, set the thermostat to Max. The fan(s) should run and heat will flow within a few minutes.

1. Turn on the electrical supply at the fused spur.
2. Set the fan speed switch to either **I** or **II**
3. Turn on the central heating system.
4. Balance the central heating system if required.
5. If the installation is working correctly remember to reset the room thermostat to its normal setting.

HEAT OUTPUT PERFORMANCE (High Speed)

Water Temperature	Eco-Powerad 500 Btu (kW)	Eco-Powerad 1000 Btu (kW)	Eco-Powerad 1500 Btu (kW)	Eco-Powerad 2000 Btu (kW)
40°	1025 (0.30)	2400 (0.70)	3075 (0.90)	4600 (1.35)
50°	1700 (0.50)	3400 (1.00)	5125 (1.50)	6825 (2.00)
75°	2900 (0.85)	7150 (2.10)	8200 (2.40)	11950 (3.50)

Based on exiting water temperature, average temperature drop is 4°C.

Guarantee Statement

Thank you for purchasing a Smith's heater.

It has been designed and manufactured to the highest quality standards to ensure it gives you efficient and trouble-free service for many years.

To back up our commitment, included with your product is a **free five year parts and labour guarantee.**

This gives you peace of mind that in the unlikely event of the product failing within the first five years, we will repair or replace the product completely free of charge provided the product has been installed, used and maintained in accordance with the instructions.

It is important to register within 7 days. This will ensure you receive a prompt and efficient service, if your product requires attention within the guarantee period. If you do not register your product, you will be required to produce a proof of purchase prior to receiving this service.

If you experience any problems with the use of your product, please contact our **after-sales office** on 01245 324560.

Smith's Environmental Products Ltd manufactures a complete range of heaters for domestic and commercial applications.

If you require any further information, please contact us on **01245 324900** or visit our website at **www.SmithsEP.co.uk**

Your statutory rights are not affected by this guarantee.

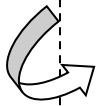

please fold along here

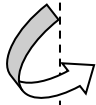

Smith's Environmental Products Ltd

Units 1 & 2 Blackall Industrial Estate

Hamberts Road

South Woodham Ferrers

Chelmsford

Essex

CM3 5UW

**Please
affix
stamp
here**

Please pull this Registration card from the booklet and fill in all parts and return.

Guarantee Registration Card & Customer Satisfaction Survey

Dear Customer

We hope our product suits all your requirements; it would help us immensely if you could find the time to fill in this form, your response will help us maintain the quality standards we all expect in today's climate.

Customer name _____ Date ____/____/____

Email Address _____@_____

Product Name _____

Tick as appropriate

	V Good	Good	Fair	Poor
Product	<input type="checkbox"/>	<input type="checkbox"/>	<input type="checkbox"/>	<input type="checkbox"/>
Delivery	<input type="checkbox"/>	<input type="checkbox"/>	<input type="checkbox"/>	<input type="checkbox"/>
Sales & Ordering	<input type="checkbox"/>	<input type="checkbox"/>	<input type="checkbox"/>	<input type="checkbox"/>
Response to any problems	<input type="checkbox"/>	<input type="checkbox"/>	<input type="checkbox"/>	<input type="checkbox"/>

Comments

.....

.....

.....

Thank you for your time to fill in this survey, the response will help us to serve your needs more effectively. Please return by fax to 01245 324422.

Quality Control Manager: Ron Brown

ron.brown@smithsep.co.uk

User Details

User Name Mr/Mrs/Miss/Ms/Other

Initials Surname

Address

.....

..... Post Code:

Telephone:

Product & Model installed (e.g. Space Saver SS5)

.....

Room Installed (e.g. Kitchen):

Your details will only be held by Smiths Environmental Products Ltd and used solely to provide customer services and product information.

If you do not wish to be contacted, please put an x in the box.

Installer Details

Company name:

Principal contact: Mr/Mrs/Miss/Ms/Other:

Initials: Surname:

Address:

.....

..... Post Code:

Telephone:

Date of installation/...../.....

Room Installed (e.g. Kitchen):

Your details will only be held by Smiths Environmental Products Ltd and used solely to provide customer services and product information.

If you do not wish to be contacted, please put an x in the box.