

IMPORTANT

- The appliance is not to be used by children or persons with reduced physical, sensory or mental capabilities, or lack of experience and knowledge, unless they have been given supervision or instruction
- Children should not be permitted to play with the appliance
- Ensure that the fan is switched off from the supply mains before removing the guard
- Any specifications with regards to dimensions of space required for the appliance to operate effectively.



Products with this symbol (crossed out wheelee bin) cannot be disposed as household waste. Old electrical and electronic equipment must be recycled at a facility capable of handling these products and their waste by-products. If you are purchasing replacement equipment your retailer may offer a 'take back' scheme, or will be able to give details of the nearest approved authorised treatment facility. Proper recycling and waste disposal will help conserve resources whilst preventing detrimental effects on our health and the environment.

WEEE Registered Code: WEE/ED0093VW

Manufactured in the



Approved CQS ISO9001:2008



Smith's Environmental Products Ltd

Blackall Industrial Estate, South Woodham Ferrers, Chelmsford, Essex, CM3 5UW

Tel: 01245 324900 Fax: 01245 324422

Sales: sales@SmithsEP.co.uk General Information E-mail: info@SmithsEP.co.uk Web: www.SmithsEP.co.uk

For Ireland, contact MT Agencies (Ireland) Ltd on Tel: 00353 1 844 3212

As part of the policy of continuous product improvement,
Smith's Environmental Products Ltd reserves the right to alter specification without prior notice.



Versatile, energy efficient heating

ECOVECTOR™

Models

LL 1200, LL 2000 & LL 2800

PATENT PENDING

INSTALLATION & USER GUIDE

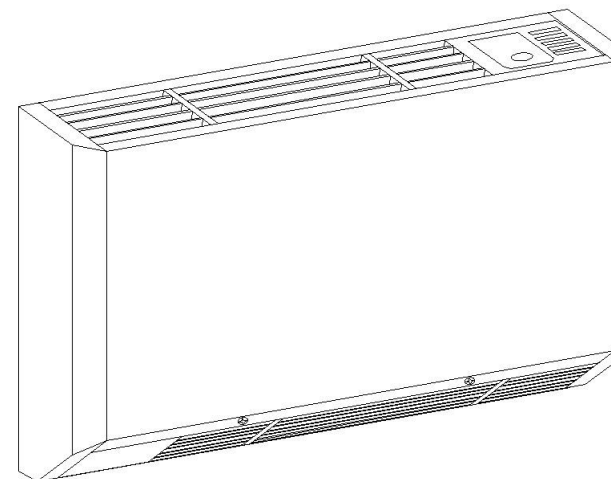

INTRODUCTION

In the event of items missing or visible damage please contact us on 01245 324560.

This heating appliance is intended for mounting on a wall at low level. The minimum recommended installation height is 150cm (6 inches) from the floor. There is no clearance required on either side of the heater.

This heater must not be used in bathrooms or other high humidity areas.

Ecovector™ is designed for use on standard two-pipe pumped central heating systems where the system hot water is generated from either a boiler or renewable sources. This product is not suitable for one-pipe heating systems. Pipe connections are 15mm.

We recommend the use of full flow isolating valves. These valves should be accessible after completion of the installation.

Ecovector™ is classified as a fixed appliance and electrical connection should be via a double pole 3A fused spur. The fused spur must not be directly above the heater but should be accessible after completion of the installation. If the pre-wired mains cable is damaged, it must be replaced by the manufacturer, its service agent or similarly qualified persons. The appliance must be earthed.

To avoid possibility of vibration, this product must be installed on a flat, even surface.

To comply with Building Regulations Part L (Part J in Scotland) this heater is fitted and controlled by an integral room thermostat.

Please note the guarantee may be invalidated if this product is not installed and used in accordance with this guide.

MOUNTING THE UNIT

Remove the EZ hanger from the back of the heater. Remove screws from the underside of the front panel, carefully lift up and remove.

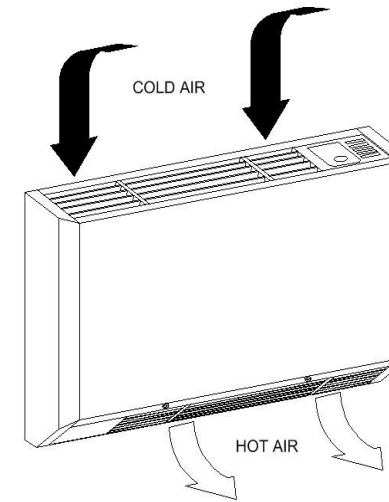
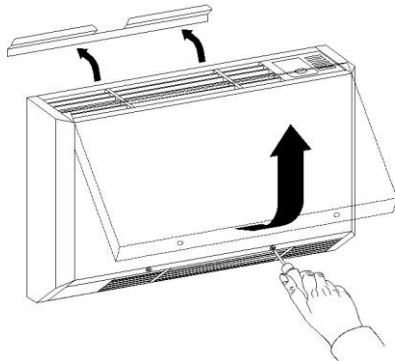

Ecovector™ includes a selectable low temperature thermostat that prevents the fan(s) operating until the central heating system water passing through the heat exchanger reaches a set temperature.

Heating

Ensure your central heating is ON, the heat output switch set to Low (I) and the thermostat set to the required position (position 3 is approximately 20°C).

If you require a faster warm up set the heat output switch to High (II)

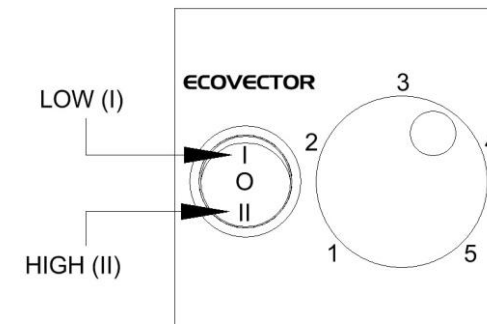

FAULT FINDING

Fan does not run on any switch setting

- Check the power source is switched ON
- Check fuse in the fused spur
- Check wiring connections at the fused spur

No heat output on settings I and II

- Check the power supply is switched ON
- Ensure the room thermostat is calling for heat
- Check the heat source switch is in the correct mode
- Balance the central heating system if installed on the same circuit as panel radiators and increase the circulating pump speed if required.
- Increase the heat source water temperature

In the event of difficulty please contact us on 01245 324560. It will be more helpful if you do not remove the product from the central heating system.

We would be most grateful if you would leave this installation & operation guide and the guarantee registration card with the owner of the property.

USER GUIDE

Your product is covered by a free 5-year parts and labour guarantee; please complete and return the Guarantee Registration Card to us as soon as possible to ensure that should you require assistance, we can help you quickly and efficiently.

Your Ecovector™ is designed to operate as part of your central heating system in the same way as a panel radiator. Providing you leave the heater switches in their normal operating positions it will switch on and off automatically with your central heating system.

Heat from your central heating system passes through a heat exchanger transferring its heat to the aluminium fins, room air is drawn in the top grille and heated as it passes through the heat exchanger before being gently expelled back into the room at floor level.

Fix the EZ hanger to the wall, position the heater on the EZ hanger and secure to the wall at the five fixing points.

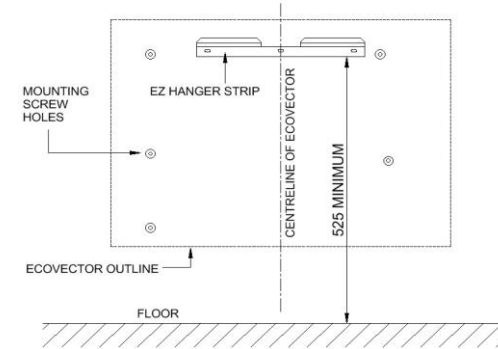

PIPE WORK

We recommend the use of full flow isolating valves. These valves should be accessible after completion of the installation. Pipe work can be brought out from the heater directly or through the rear chassis. A lower panel blanking plate is packed and supplied with the heater if the latter option is used (to fit this remove the 3 screws from the fitted slotted pipe access panel and replace with the blanking plate).

Connect the heating system flow and return pipes to the heater pipe work. Do not use soldered fittings to the heater pipe work as the heat generated could damage internal wiring and components. The pipe nearest the front of the heater is the supply flow and the pipe nearest the chassis is the return.

Check for water leaks. Remove any trapped air from the system via the vent valve on the top left hand side of the heat exchanger. Do not over tighten the air vent

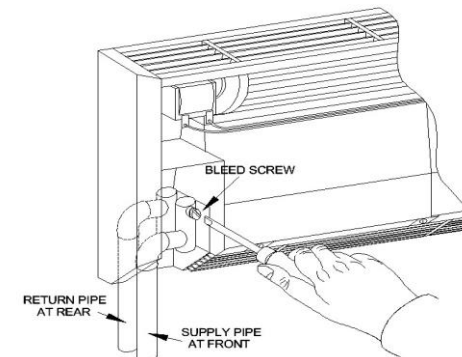

ELECTRICAL CONNECTION

ALL ELECTRICAL INSTALLATIONS CONNECTIONS MUST COMPLY WITH BS7671, 1992 AND THE IEE REGULATIONS. CHECK THE VOLTAGE ON THE HEATER IS CORRECT FOR YOUR SUPPLY. IF IN DOUBT, CONSULT A QUALIFIED ELECTRICIAN.

If the pre-wired mains cable is damaged, it must be replaced by the manufacturer, its service agent or similarly qualified persons.

Isolate the supply and connect the heater three core mains lead to the fused spur (3A) in accordance with the instructions provided on the mains lead label. (The supply wire which is coloured green or green and yellow must be connected to the terminal marked **E** on the appliance, the supply wire which is coloured black or blue must be connected to the terminal marked **N** on the appliance and the supply wire which is coloured red or brown must be connected to the terminal marked **L** on the appliance).

The fused spur must not be directly above the heater but should be accessible after completion of the installation.

COMMISSIONING

This heater is equipped with a selectable low temperature cut out thermostat which requires the correct system hot water to be sensed before the fan(s) will run. The heat source switch can be set to run on either renewable (+38°C) or boiler mode (+52°C).

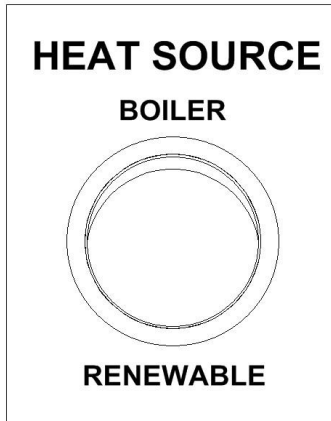

Set the heat source switch to the correct mode, turn on the electrical supply at the fused spur, switch on the central heating system, set the thermostat and the heat output switch to Low (I) or High (II). The fan(s) should run and heat will flow within a few minutes.

If this heater is installed on the same circuit as panel radiators balance the central heating system.

When the installation is working correctly, remember to reset the room thermostat to its normal setting.

INSTALLATION COMPLETION

Attach the earth bonding connector to the outer casing and refit the outer casing to the chassis.

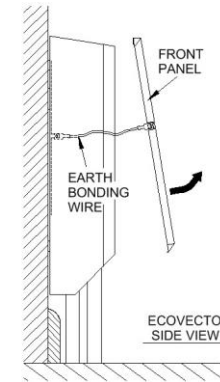

HEAT OUTPUT PERFORMANCE

It is recommended that the Ecovector™ model is capable of maintaining the calculated heat losses at Low (I) heat output enabling High (II) to be used for faster heat output.

Δt	Ecovector™ LL 1200		Ecovector™ LL2000		Ecovector™ LL 2800	
	Low (I) Btu (kW)	High (II) Btu (kW)	Low (I) Btu (kW)	High (II) Btu (kW)	Low (I) Btu (kW)	High (II) Btu (kW)
20°C	1200 (0.4)	1600 (0.5)	2500 (0.7)	2900 (0.9)	3200 (1.0)	4200 (1.2)
50°C	3400 (1.0)	4300 (1.3)	5500 (1.6)	7600 (2.2)	8000 (2.3)	10000 (2.9)
60°C	4000 (1.2)	5400 (1.6)	6900 (2.0)	8800 (2.6)	9700 (2.8)	12100 (3.5)

Notes

$\Delta t60^\circ\text{C}$ assumes a mean water temperature of 80°C and room temperature of 20°C

$\Delta t50^\circ\text{C}$ assumes a mean water temperature of 70°C and room temperature of 20°C

$\Delta t20^\circ\text{C}$ assumes a mean water temperature of 40°C and room temperature of 20°C

Guarantee Statement

Thank you for purchasing a Smith's heater.

It has been designed and manufactured to the highest quality standards to ensure it gives you efficient and trouble-free service for many years.

To back up our commitment, included with your product is a **free five year parts and labour guarantee.**

This gives you peace of mind that in the unlikely event of the product failing within the first five years, we will repair or replace the product completely free of charge provided the product has been installed, used and maintained in accordance with the instructions.

It is important to register within 7 days. This will ensure you receive a prompt and efficient service, if your product requires attention within the guarantee period. If you do not register your product, you will be required to produce a proof of purchase prior to receiving this service.

If you experience any problems with the use of your product, please contact our **after-sales office** on 01245 324560.

Smith's Environmental Products Ltd manufactures a complete range of heaters for domestic and commercial applications.

If you require any further information, please contact us on **01245 324900** or visit our website at **www.SmithsEP.co.uk**

Your statutory rights are not affected by this guarantee.

Please pull this Registration card from the booklet and fill in all parts and return.



please fold along here

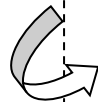

Smith's Environmental Products Ltd

Units 1 & 2 Blackall Industrial Estate

Hamberts Road

South Woodham Ferrers

Chelmsford

Essex

CM3 5UW

**Please
affix
stamp
here**

User Details

User Name Mr/Mrs/Miss/Ms/Other

Initials Surname

Address

.....

..... Post Code:

Telephone:

Product & Model installed (e.g. Space Saver SS5)

.....

Room Installed (e.g. Kitchen):

Your details will only be held by Smiths Environmental Products Ltd and used solely to provide customer services and product information.
If you do not wish to be contacted, please put an x in the box.

Installer Details

Company name:

Principal contact: Mr/Mrs/Miss/Ms/Other:

Initials: Surname:

Address:

.....

..... Post Code:

Telephone:

Date of installation/...../.....

Room Installed (e.g. Kitchen):

Your details will only be held by Smiths Environmental Products Ltd and used solely to provide customer services and product information.
If you do not wish to be contacted, please put an x in the box.

Guarantee Registration Card & Customer Satisfaction Survey

Dear Customer

We hope our product suits all your requirements; it would help us immensely if you could find the time to fill in this form, your response will help us maintain the quality standards we all expect in today's climate.

Customer name _____ Date ____/____/____

Email Address _____@_____

Product Name _____

Tick as appropriate

	V Good	Good	Fair	Poor
Product	<input type="checkbox"/>	<input type="checkbox"/>	<input type="checkbox"/>	<input type="checkbox"/>
Delivery	<input type="checkbox"/>	<input type="checkbox"/>	<input type="checkbox"/>	<input type="checkbox"/>
Sales & Ordering	<input type="checkbox"/>	<input type="checkbox"/>	<input type="checkbox"/>	<input type="checkbox"/>
Response to any problems	<input type="checkbox"/>	<input type="checkbox"/>	<input type="checkbox"/>	<input type="checkbox"/>

Comments

Thank you for your time to fill in this survey, the response will help us to serve your needs more effectively. Please return by fax to 01245324422.

Quality Control Manager: Ron Brown

ron.brown@smithsep.co.uk