

Aegean SFC 180H

A range of fan coil units suitable for all kinds of commercial applications, from restaurants and hotels to office developments, with the ability to rapidly heat and cool large areas with much greater efficiency than other similar heating and cooling systems



Features

- Suitable for shallow ceiling voids
- EC motor for BMS compliance
- Low sound levels
- Fully attenuated discharge plenum
- Positive fall drain tray
- Designed and made in the UK
- For bespoke specifications, including electric heating capability please contact us to discuss your requirements

Applications

- Education
- Healthcare
- Leisure and sport
- Office
- Hospitality
- Retail
- Showroom
- Industrial

Finish

Chassis manufactured from 1.2mm hot dipped galvanised steel
All flanges formed inward facing to prevent exposure to bare metal edges

Installation

Flow and return connections 15mm
Designed for system pressures up to 10 bar
Fan coils are 4-pipe coils (heating and cooling circuit)

Customised requirements

All leading manufacturers controls factory fitted
Acoustically lined inlet plenum
Concealed/hidden applications (underfloor, behind false walls and ceilings)
Fresh air spigot
Bespoke options

Specification

To specify state:
Horizontal Fan Coil Unit 180mm high with EC motor.
As Smith's Aegean SFC18010 (or SFC18020, SFC18030, SFC18040)

Aegean SFC 180H



A range of fan coil units suitable for all kinds of commercial applications, from restaurants and hotels to office developments, with the ability to rapidly heat and cool large areas with much greater efficiency than other similar heating and cooling systems

Cooling capacities

Unit Model	Fan speed	Chilled water temp. 5.5°C/11°C					
		Entering air temp. °C db/RH					
		22/50%		23/50%		24/50%	
		Total kW	Sens kW	Total kW	Sens kW	Total kW	Sens kW
SFC 18010	1	0.50	0.36	0.55	0.38	0.60	0.40
	2	0.85	0.65	0.96	0.70	1.10	0.76
	3	1.14	0.91	1.31	0.99	1.49	1.07
	4	1.41	1.14	1.61	1.24	1.83	1.33
	5	1.68	1.37	1.90	1.48	2.14	1.58
SFC 18020	1	0.67	0.48	0.74	0.51	0.81	0.54
	2	1.11	0.88	1.24	0.94	1.40	1.00
	3	1.33	1.14	1.60	1.28	1.89	1.42
	4	1.80	1.53	2.11	1.70	2.43	1.85
	5	2.22	1.89	2.56	2.07	2.91	2.24
SFC 18030	1	0.95	0.70	1.06	0.74	1.16	0.78
	2	1.40	1.19	1.56	1.27	1.72	1.35
	3	1.79	1.59	2.25	1.88	2.69	2.11
	4	2.63	2.30	3.09	2.57	3.55	2.81
	5	3.25	2.86	3.74	3.15	4.24	3.41
SFC 18040	1	1.20	0.87	1.32	0.92	1.45	0.97
	2	1.97	1.59	2.39	1.80	2.77	1.97
	3	3.12	2.53	3.58	2.75	4.07	2.96
	4	4.09	3.36	4.64	3.62	5.22	3.88
	5	4.89	4.09	5.53	4.40	6.23	4.72

Unit Model	Fan speed	Chilled water temp. 11°C/15°C					
		Entering air temp. °C db/RH					
		22/50%		23/50%		24/50%	
		Total kW	Sens kW	Total kW	Sens kW	Total kW	Sens kW
SFC 18010	1	0.25	0.24	0.29	0.26	0.35	0.28
	2	0.46	0.44	0.52	0.49	0.61	0.54
	3	0.62	0.60	0.72	0.69	0.85	0.78
	4	0.79	0.75	0.91	0.86	1.05	0.96
	5	0.94	0.90	1.08	1.03	1.25	1.15
SFC 18020	1	0.33	0.32	0.40	0.35	0.46	0.38
	2	0.62	0.60	0.70	0.66	0.81	0.73
	3	0.79	0.76	0.93	0.88	1.10	1.02
	4	1.05	1.00	1.24	1.17	1.43	1.33
	5	1.30	1.24	1.51	1.43	1.74	1.62
SFC 18030	1	0.48	0.47	0.58	0.52	0.67	0.57
	2	0.84	0.80	0.95	0.90	1.06	0.99
	3	1.10	1.05	1.37	1.29	1.63	1.52
	4	1.58	1.50	1.89	1.79	2.18	2.03
	5	1.98	1.88	2.31	2.18	2.64	2.47
SFC 18040	1	0.60	0.58	0.72	0.64	0.84	0.70
	2	1.09	1.05	1.29	1.22	1.55	1.40
	3	1.73	1.66	2.02	1.91	2.33	2.13
	4	2.32	2.23	2.66	2.52	3.04	2.80
	5	2.84	2.72	3.24	3.07	3.67	3.40

Heating capacities

Unit Model	Fan speed	Chilled water temp. 6°C/12°C					
		Entering air temp. °C db/RH					
		22/50%		23/50%		24/50%	
		Total kW	Sens kW	Total kW	Sens kW	Total kW	Sens kW
SFC 18010	1	0.47	0.34	0.52	0.37	0.58	0.39
	2	0.78	0.62	0.88	0.66	0.98	0.70
	3	0.96	0.81	1.15	0.91	1.34	1.00
	4	1.22	1.04	1.43	1.15	1.66	1.25
	5	1.47	1.25	1.71	1.38	1.95	1.49
SFC 18020	1	0.63	0.46	0.70	0.49	0.77	0.52
	2	1.03	0.84	1.15	0.89	1.29	0.95
	3	1.22	1.07	1.36	1.15	1.57	1.26
	4	1.44	1.29	1.78	1.51	2.12	1.69
	5	1.86	1.66	2.23	1.88	2.58	2.07
SFC 18030	1	0.88	0.66	0.99	0.71	1.09	0.75
	2	1.30	1.13	1.44	1.21	1.59	1.28
	3	1.65	1.49	1.81	1.59	2.16	1.81
	4	1.94	1.77	2.56	2.24	3.08	2.55
	5	2.71	2.46	3.24	2.83	3.75	3.14
SFC 18040	1	1.12	0.83	1.24	0.88	1.38	0.94
	2	1.73	1.46	1.93	1.56	2.41	1.79
	3	2.67	2.27	3.17	2.54	3.66	2.77
	4	3.62	3.09	4.17	3.38	4.75	3.65
	5	4.38	3.79	5.00	4.12	5.66	4.44

Unit Model	Fan speed	Entering air temp 20°C db	
		LPHW 82/71°C	LPHW 60/50°C
SFC 18010	1	1.07	0.59
	2	1.40	0.77
	3	1.61	0.90
	4	1.89	1.05
	5	2.15	1.20
SFC 18020	1	1.51	0.88
	2	2.09	1.20
	3	2.31	1.31
	4	2.75	1.57
	5	3.17	1.80
SFC 18030	1	2.03	1.20
	2	2.42	1.39
	3	3.14	1.79
	4	3.81	2.17
	5	4.36	2.49
SFC 18040	1	2.05	1.04
	2	2.24	1.14
	3	2.87	1.51
	4	3.48	1.86
	5	3.97	2.15

- A) Duties are based on 30 Pa ESP.
- B) Refer to air Volume & Cooling Correction Factors chart for alternative ESP conditions.
- C) For alternative chilled water conditions please contact Smith's Environmental Systems Ltd.
- D) For full technical selection schedules including water flow rate and pressure drops, please contact Smith's Environmental Systems Ltd.

- A) Duties above are based on 30 Pa ESP.
- B) For alternative ESP conditions, please contact Smith's Environmental Systems Ltd.
- C) For alternative 'air on' temperatures, calculate the factor as below and multiply by mean basic rating to obtain new capacity.
Factor: Calculate the mean water temperature (i.e. EWT/LWT of 60°/50°C = 55 EWT/LWT of 82°/71°C = 76.5) minus the required 'air on' temperature.
Example: For an 'air on' temperature of 19°C and EWT/LWT of 60/50°C then the calculation would be 55/19 = 36. Therefore, to attain the capacity of SFC 50 at speed 3, take the mean basic rating (0.0734) and multiply by factor(36); 0.0734 x 36 = 2.64 kW.
- D) For full technical selection schedules including water flow rates & pressure drops please contact Smith's.
- E) Duties are based on a standard 4-tube heating circuit. Larger duties are achievable by increasing heating coil circuitry. Please contact Smith's for further details.

Aegean SFC 180H



A range of fan coil units suitable for all kinds of commercial applications, from restaurants and hotels to office developments, with the ability to rapidly heat and cool large areas with much greater efficiency than other similar heating and cooling systems

Acoustic Data

Unit Model	Fan speed	Octave Band Mid Frequency (Hz)								NR guide		
		63	125	250	500	1k	2k	4k	8k			
SFC 18010	1	Inlet & Casing	38	40	37	33	31	14	13	19	31	
		Discharge	32	33	22	23	16	0	11	15	22	
	2	Inlet & Casing	43	43	39	37	34	23	13	19	35	
		Discharge	33	25	26	26	20	7	5	10	28	
	3	Inlet & Casing	42	45	41	39	37	21	9	14	37	
		Discharge	33	30	31	31	24	15	7	10	33	
	4	Inlet & Casing	50	50	45	44	40	33	21	19	41	
		Discharge	39	33	35	37	30	24	13	10	39	
	5	Inlet & Casing	53	54	49	49	44	39	24	15	46	
		Discharge	45	40	41	43	36	32	23	13	44	
	SFC 18020	1	Inlet & Casing	40	41	38	34	32	17	18	21	33
			Discharge	35	34	25	25	18	3	11	15	24
		2	Inlet & Casing	44	44	40	38	36	24	14	19	36
			Discharge	35	29	29	29	23	10	7	11	29
		3	Inlet & Casing	44	46	42	41	38	24	11	16	39
Discharge			36	33	33	33	27	18	9	11	34	
4		Inlet & Casing	51	50	47	45	42	35	22	19	42	
		Discharge	42	36	38	39	33	26	15	11	40	
5		Inlet & Casing	55	56	51	51	46	41	27	18	48	
		Discharge	48	43	44	45	38	34	25	15	45	
SFC 18030		1	Inlet & Casing	45	42	41	38	35	23	26	24	36
			Discharge	41	35	29	29	24	9	13	15	27
		2	Inlet & Casing	46	46	43	41	39	28	15	20	39
			Discharge	41	35	34	34	29	16	10	13	32
		3	Inlet & Casing	48	48	45	44	41	31	17	19	42
	Discharge		43	38	38	38	33	23	12	13	36	
	4	Inlet & Casing	52	52	49	48	44	38	25	20	45	
		Discharge	47	42	42	44	38	30	18	14	42	
	5	Inlet & Casing	58	59	54	53	49	44	33	24	51	
		Discharge	54	50	49	50	44	38	30	21	48	
	SFC 18040	1	Inlet & Casing	48	43	42	39	37	26	31	26	37
			Discharge	44	36	32	31	26	12	14	15	28
		2	Inlet & Casing	47	47	44	43	40	30	16	20	40
			Discharge	43	39	37	37	32	19	12	15	33
		3	Inlet & Casing	50	49	47	46	43	34	19	20	43
Discharge			46	41	40	40	36	26	13	15	37	
4		Inlet & Casing	53	52	50	49	46	39	26	20	46	
		Discharge	50	45	45	46	40	32	20	16	43	
5		Inlet & Casing	60	61	56	55	51	46	36	27	52	
		Discharge	57	53	52	52	47	41	33	23	49	

- A) The acoustic data provides is based on an ESP of 30 Pa.
 B) Inlet & casing figures are sound power levels (SWL DB ref 10⁻¹² W).
 The following factors have been applied to the discharge sound spectrum state to allow for ductwork, plenum and grille:

63	125	250	500	1k	2k	4k	8k	(Hz)
-5	-5	-5	-9	-10	-10	-9	-3	(dB)

- (Add factors back into discharge spectrum to return to sound power levels)
 C) NR figures are given for guide purposes only and cannot relate to every given application.
 We recommend that the advice of an acoustic engineer is sought on individual projects in order to obtain accurate NR levels for a given space.
 D) Consideration must be given to spigot connection number and dimensions in order to achieve acceptable air velocities (2.5m/s or below). This includes connected ductwork as increased velocity will in turn increase sound levels.

Air volumes

Unit Model	Fan speed	Air Volume l/s V's ESP				
		10 Pa	20 Pa	30 Pa	40 Pa	50 Pa
SFC 18010	1	56	51	45	40	33
	2	70	64	60	56	51
	3	86	80	75	71	69
	4	102	96	91	87	84
	5	117	110	106	104	102
SFC 18020	1	91	82	72	67	62
	2	123	112	108	104	102
	3	158	149	145	141	136
	4	195	186	180	177	172
	5	229	220	216	210	207
SFC 18030	1	135	119	115	110	100
	2	185	175	165	160	155
	3	238	230	222	218	214
	4	288	278	270	260	256
	5	330	322	320	312	307
SFC 18040	1	174	157	145	133	121
	2	238	226	211	203	192
	3	302	294	290	279	269
	4	366	360	351	344	337
	5	430	420	412	404	398

- A) Refer to air volumes at 30 Pa ESP for cooling capacity charts
 B) Refer to appropriate ESP condition when applying correction factors to cooling capacity.

Power input and starting/running currents

Model (kW)	Nominal motor rating (Watts)	Max. running current (Amps)
SFC 18010	1 x 28	0.22
SFC 18020	1 x 45	0.33
SFC 18030	2 x 78	0.55
SFC 18040	2 x 95	0.66

Based on 230/1/50 supply and 30Pa ESP at maximum speed

Aegean SFC 180H



A range of fan coil units suitable for all kinds of commercial applications, from restaurants and hotels to office developments, with the ability to rapidly heat and cool large areas with much greater efficiency than other similar heating and cooling systems

Cooling correction factors

Unit Model	Fan speed	Cooling duty correction factors									
		10 Pa		20 Pa		30Pa		40 Pa		50 pa	
		Tot Clg	Sens Clg	Tot Clg	Sens Clg	Tot Clg	Sens Clg	Tot Clg	Sens Clg	Tot Clg	Sens Clg
SFC 18010	1	N/A	N/A	N/A	N/A	N/A	N/A	N/A	N/A	N/A	N/A
	2	1.13	1.16	1.07	1.09	1.00	1.00	0.94	0.93	0.90	0.88
	3	1.09	1.11	1.05	1.05	1.00	1.00	0.96	0.95	0.91	0.90
	4	1.05	1.05	1.02	1.02	1.00	1.00	0.97	0.96	0.94	0.93
	5	1.05	1.05	1.02	1.02	1.00	1.00	0.99	0.98	0.97	0.96
SFC 18020	1	1.14	1.18	1.09	1.11	1.00	1.00	0.94	0.93	0.89	0.87
	2	1.09	1.11	1.04	1.04	1.00	1.00	0.97	0.96	0.93	0.92
	3	1.07	1.09	1.05	1.05	1.00	1.00	0.97	0.97	0.95	0.94
	4	1.05	1.06	1.03	1.03	1.00	1.00	0.98	0.98	0.96	0.95
	5	1.02	1.03	1.01	1.01	1.00	1.00	0.98	0.98	0.96	0.95
SFC 18030	1	1.13	1.16	1.04	1.04	1.00	1.00	0.92	0.91	0.88	0.85
	2	1.05	1.06	1.02	1.03	1.00	1.00	0.96	0.95	0.91	0.90
	3	1.07	1.09	1.03	1.03	1.00	1.00	0.97	0.97	0.94	0.93
	4	1.03	1.03	1.02	1.02	1.00	1.00	0.98	0.98	0.94	0.93
	5	1.05	1.05	1.03	1.03	1.00	1.00	0.97	0.97	0.95	0.94
SFC 18040	1	1.13	1.16	1.07	1.09	1.00	1.00	0.93	0.92	0.88	0.85
	2	1.09	1.11	1.03	1.03	1.00	1.00	0.95	0.94	0.90	0.88
	3	1.05	1.06	1.03	1.03	1.00	1.00	0.97	0.96	0.93	0.92
	4	1.05	1.06	1.02	1.02	1.00	1.00	0.98	0.98	0.96	0.95
	5	1.03	1.03	1.02	1.02	1.00	1.00	0.98	0.98	0.96	0.95

A) Cooling correction factors to be applied to cooling capacities to provide duty for the required ESP condition.

B) For alternative ESP conditions please contact Smith's Environmental Systems Ltd.

Aegean SFC 180H

A range of fan coil units suitable for all kinds of commercial applications, from restaurants and hotels to office developments, with the ability to rapidly heat and cool large areas with much greater efficiency than other similar heating and cooling systems

Dimensions

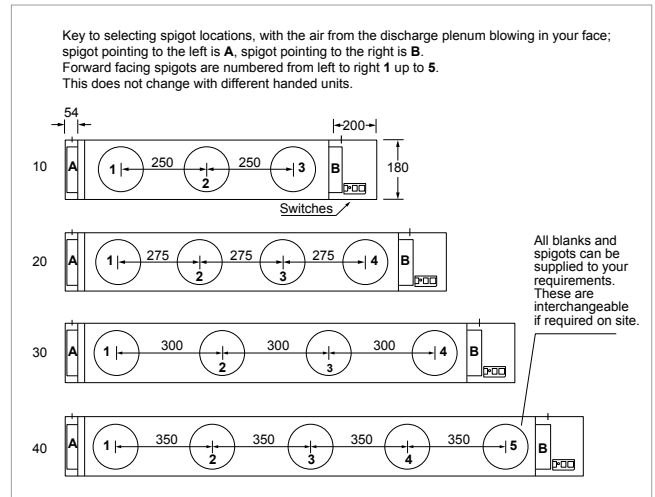
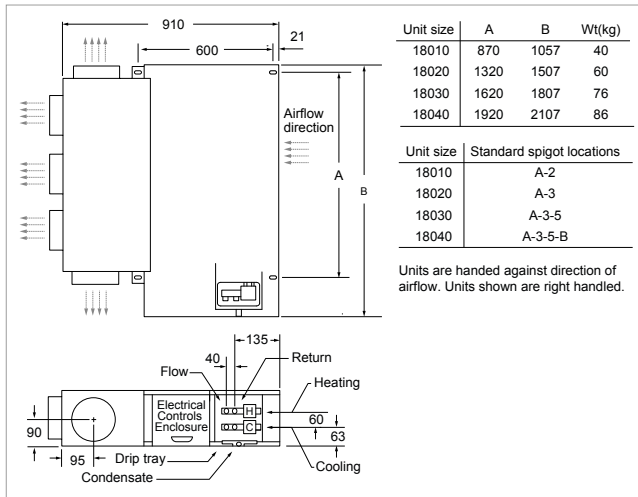

Electrical data - Wiring diagram

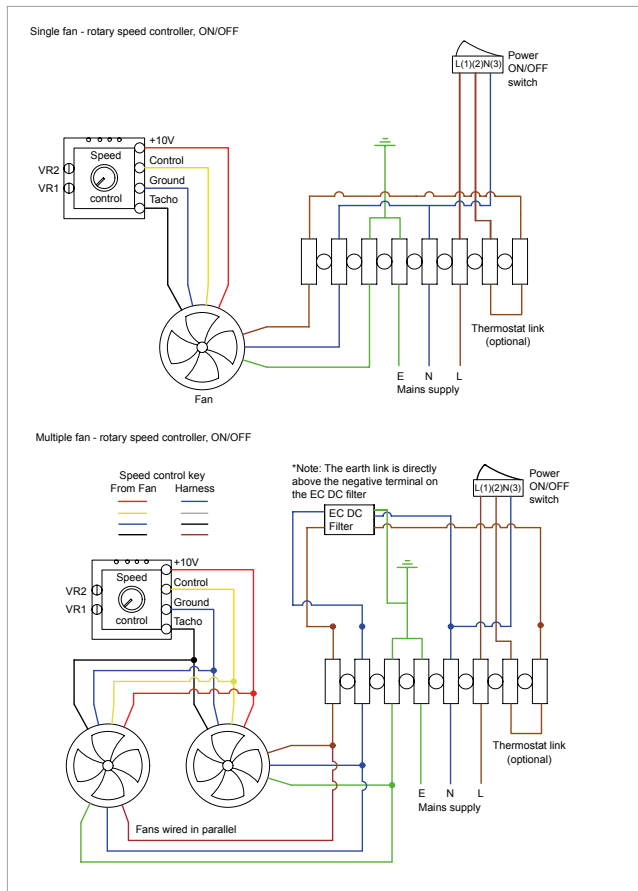

Ordering guide

Listed below are the basic models. For all other variants please visit our website for the most up to date information.

Description	Weight (Kg)	Product code
Aegean SFC 180		
Aegean SFC180EC/10	40	HPAE20000
Aegean SFC180EC/20	60	HPAE20001
Aegean SFC180EC/30	76	HPAE20002
Aegean SFC180EC/40	86	HPAE20003

For bespoke specifications, including electric heating capability please contact us to discuss your requirements

As part our commitment to continuous improvement Smith's Environmental Products may change the specifications of its products without prior notification or public announcement. All descriptions, illustrations, drawings and specifications in this publication present only general particulars and shall not form part of any contract. All dimensions are in mm unless otherwise stated.