

Skyline

The electric Skyline fits neatly into existing ceiling space - replacing a 600mm x 600mm ceiling tile and because it is ceiling mounted, it saves valuable wall space - particularly important in retail units

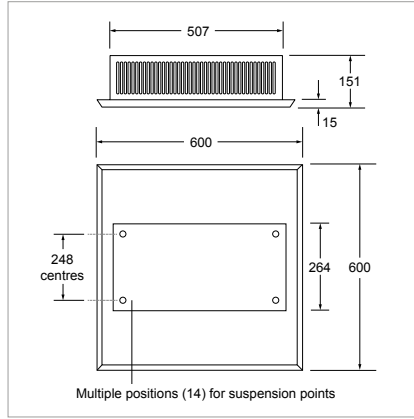

Features

- It is unobtrusive and effective
- This high output fan convector effectively heats large areas
- Supplied as standard in white but can be supplied in any colour

Applications

- Education
- Healthcare
- Leisure and sport
- Office
- Hospitality
- Retail
- Industrial

Motor

AC only

Finish

Outer casing 0.9mm zinc-coated steel
Polyester powder-coated
Polyester powder-coated RAL 9010

Installation

Maximum installation height 3.2m (10'6") to underside
Minimum 150mm void space required for recessed installation
Not suitable for bathrooms and other high humidity areas
Two air inlet options: room only, room and void

Maximum flexibility in installation: only 600mm - side clearance required

Facility for connection to 6mm threaded rod or chains (rods and chains - not supplied)

20 amp fused spur required

Unit must be earthed

Supplied with remote operating switch

Control

Rocker switches for fan and element

Overheat protection: thermal cut-out.

Manual reset procedure: switch power off at mains, wait 5 minutes, switch power on

Mains powered wireless controller with temperature control, setback temperature and run back timer

Attachment

Surface mounting kit - 135mm. Provides a complete foursided trim when fitted to a solid ceiling

Ceiling tile spacer (85mm)

Specification

To specify state: Ceiling mounted heat emitter at 4Kw in white 600x600mm. As Smith's Skyline.

Heat output

Model	Heat Output (Kw)
SKYLINE E 4KW	4.0

Ordering guide

Model	Packed Wt (kg)	Product Codes
SKYLINE E 4KW	9	HPSK40003
Attachments		
SKYLINE SURFACE MOUNTING KIT (135MM)		HASK40102
SKYLINE CEILING TILE SPACER (85MM)		HASK40103

Model	Mains cable	Fused spur	Total Power Consumption (kW)	Sound Levels (dBA)	Casting colour	Fan-only
SKYLINE E 4KW	1.5m	20A	4.1	40	white	n/a

As part our commitment to continuous improvement Smith's Environmental Products may change the specifications of its products without prior notification or public announcement. All descriptions, illustrations, drawings and specifications in this publication present only general particulars and shall not form part of any contract. All dimensions are in mm unless otherwise stated.