



Products with this symbol (crossed out wheeled bin) cannot be disposed as household waste. Old electrical and electronic equipment must be recycled at a facility capable of handling these products and their waste by-products. If you are purchasing replacement equipment your retailer may offer a 'take back' scheme, or will be able to give details of the nearest approved authorised treatment facility. Proper recycling and waste disposal will help conserve resources whilst preventing detrimental effects on our health and the environment.

WEEE Registered Code: WEE/ED0093VW

Accessory grilles which fit in place standard grille are available in different colours and finishes. Please consult the price list for details. In the event of any items missing or visible damage, please contact us on 01245 324560.

Please leave this Installation & User Guide and the Guarantee Registration Card with the intended user.



Approved CQS ISO 9001:2008



Smith's Environmental Products Ltd,

Blackall Industrial Estate, South Woodham Ferrers, Chelmsford, Essex, CM3 5UW

Tel: 01245 324900 Fax: 01245 324422

Sales E-mail: sales@smiths-env.com General Information E-mail: info@smiths-env.com Web: www.smiths-env.com

For Ireland, contact MT Agencies (Ireland) Ltd on Tel: 00353 1 844 3212



Space Saver

SS80E

Installation and User Guide

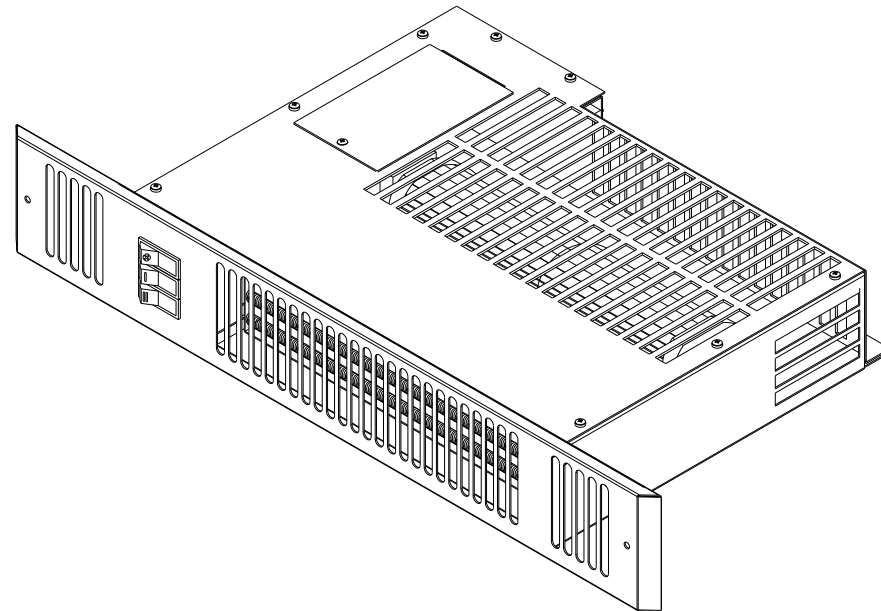

Thermostat Wiring:

1. To link a room thermostat remove the electrical panel on the back of the unit by removing the 2 fixing screws (See below diagram)

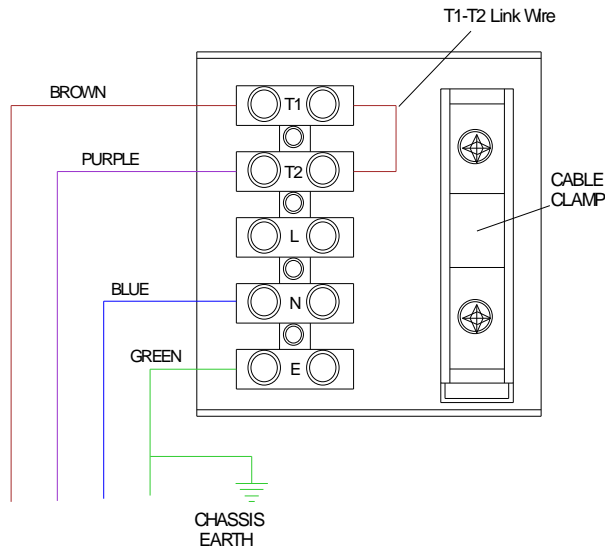
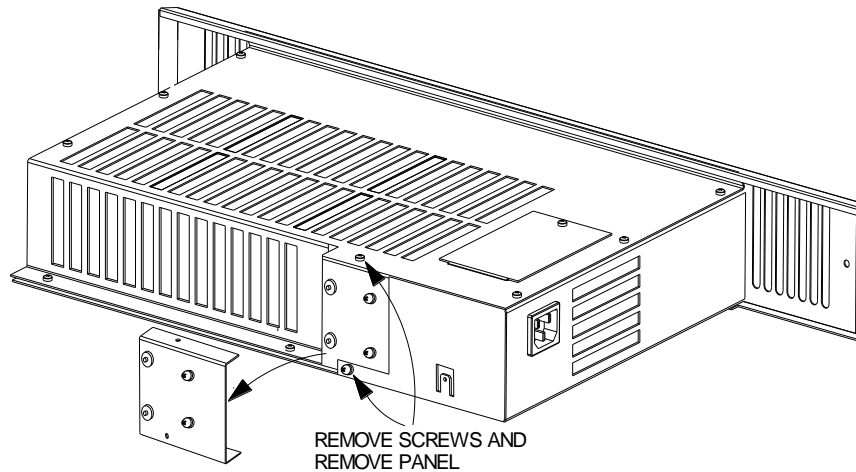

2. Remove T1 – T2 link wire (See above diagram) and connect room thermostat (not supplied) following the manufacturer's instructions.

SS 80 mm

The following items should be included in the carton:

- ❖ Product complete with stainless steel grille and plug and play lead.
- ❖ Fixing screws (2).

Space Saver is primarily intended for installation in the space beneath kitchen cupboards behind the plinth. However it can also be installed in similar applications such as stair risers and other built-in furniture.

This Space Saver model must not be installed in a bathroom or other high humidity area. Please contact us on 01245 324560 for details of products suitable for these applications.

Space Saver is classified as a fixed appliance and electrical connection should be via a double pole 10A fused spur. The fused spur must not be directly above the heater but should be accessible after

If the mains cable is damaged, it must be replaced by either the manufacturer, its service agent or similarly qualified persons. The appliance must be earthed.

To avoid the possibility of vibration, this product must be installed on a flat, even surface.

To conform with Building Regulations Part L (Part J in Scotland), a remote room thermostat (Smith's Part No. 08-0826) can be used in conjunction with this Space Saver fan convector.

Please note the guarantee may be invalidated if this product is not installed and used in accordance with

Installation Guide

1. We recommend the use of a kneepad when installing this product. Cut the opening in the plinth using method 1, 2 or 3 (Method 1 represents installation into an 80mm plinth).

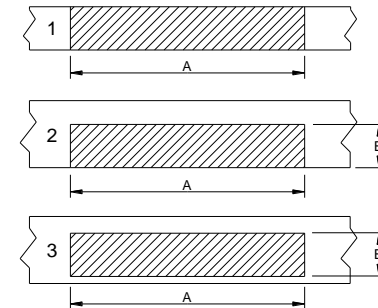

Model	Width A	Width B
SS 80E	400 mm	74 mm

2. Isolate the electrical supply and connect the heater the electrical cable to the 10A fused spur. The fused spur must not be directly above the heater but should be accessible after completion of the installation.

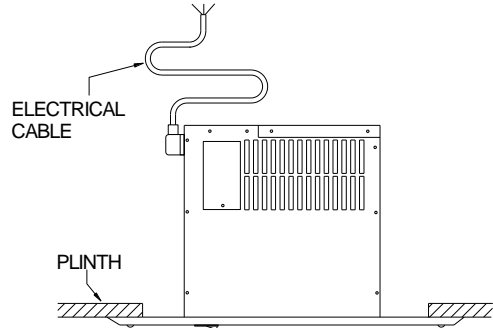

3. Note if a room thermostat is to be fitted refer to page 7 before continuing.

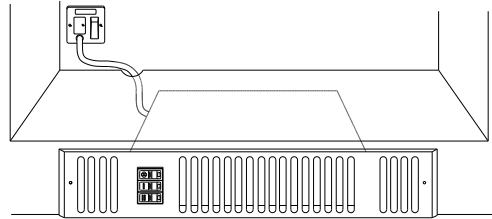

4. Plug the electrical cable into the heater.

5. Position the heater ensuring that the electrical cable is not snagged.

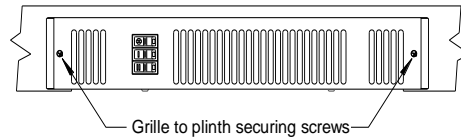

6. Fix the heater to the plinth

Heating

Before switching the heater on for the first time ensure the fascia grille is free from obstruction.

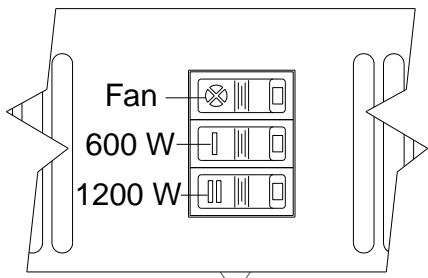

Ensure the fused spur is switch **ON**. Set the thermostat (If fitted) to maximum.

Set the upper fan switch and the middle 600W switch to the **ON** position. If a higher heat setting is required then set the bottom 1200W switch to the **ON** position.

Set the thermostat (If fitted) to its required setting.

Air Circulation (Summer Use)

The heater may be used in fan only mode by setting the upper switch to the **ON** position, both other switches must be **OFF**.

Fault Finding

1. The fan does not run/ no heat output

- Check the power supply is switched ON.
- Check the fuse in the fused spur.
- Check the switches on fan switch is in the on position on the heater

2. If the overheat protection has activated, manually reset as follows.

- Switch the power supply **OFF** at the fused spur
- Wait five minutes for the overheat cut out switch to reset
- Switch the power supply back **ON** at the fused spur

This Space Saver is covered by a free 5-year parts and labour guarantee.

In the event of difficulty, please contact us on 01245 324560.

Dimensional Drawing:

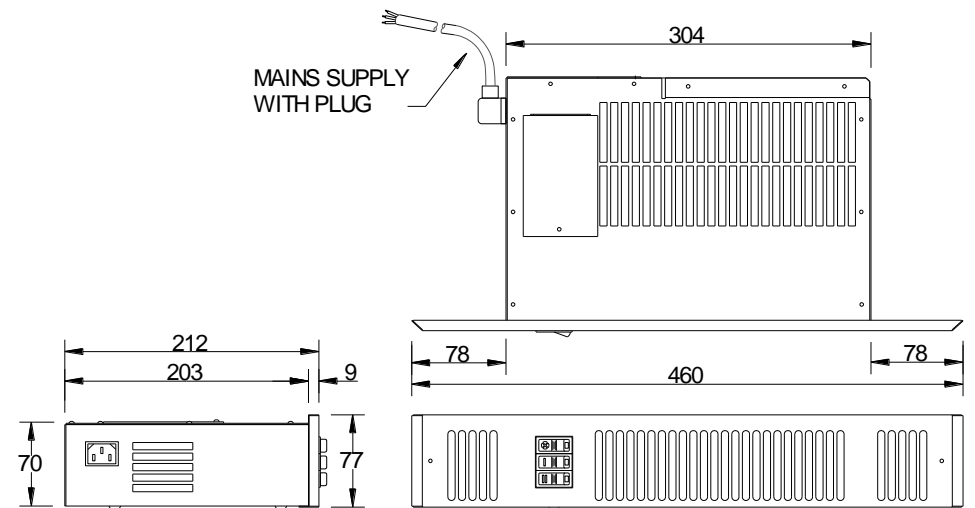

Guarantee Statement

Thank you for purchasing a Smith's heater.

It has been designed and manufactured to the highest quality standards to ensure it gives you efficient and trouble-free service for many years.

To back up our commitment, included with your product is a **free five year parts and labour guarantee**.

This gives you peace of mind that in the unlikely event of the product failing within the first five years, we will repair or replace the product completely free of charge provided the product has been installed, used and maintained in accordance with the instructions.

It is important to register within 7 days. This will ensure you receive a prompt and efficient service, if your product requires attention within the guarantee period. If you do not register your product, you will be required to produce a proof of purchase prior to receiving this service.

If you experience any problems with the use of your product, please contact our **after-sales office** on 01245 324560.

Smith's Environmental Products Ltd manufactures a complete range of heaters for domestic and commercial applications.

If you require any further information, please contact us on **01245 324900** or visit our website at **www.smiths-env.com**.

Your statutory rights are not affected by this guarantee.

Please pull this Registration card from the booklet and fill in all parts and return.



please fold along here



Smith's Environmental Products Ltd

Units 1 & 2 Blackall Industrial Estate

Hamberts Road

South Woodham Ferrers

Chelmsford

Essex

CM3 5UW

**Please
affix
stamp
here**

**Guarantee Registration Card
& Customer Satisfaction Survey**

Dear Customer

We hope our product suits all your requirements; it would help us immensely if you could find the time to fill in this form, your response will help us maintain the quality standards we all expect in today's climate.

Customer name _____ Date ____/____/____

Email Address _____@_____

Product Name _____

Tick as appropriate

	V Good	Good	Fair	Poor
Product	<input type="checkbox"/>	<input type="checkbox"/>	<input type="checkbox"/>	<input type="checkbox"/>
Delivery	<input type="checkbox"/>	<input type="checkbox"/>	<input type="checkbox"/>	<input type="checkbox"/>
Sales & Ordering	<input type="checkbox"/>	<input type="checkbox"/>	<input type="checkbox"/>	<input type="checkbox"/>
Response to any problems	<input type="checkbox"/>	<input type="checkbox"/>	<input type="checkbox"/>	<input type="checkbox"/>

Comments _____

Thank you for your time to fill in this survey, the response will help us to serve your needs more effectively. Please return by fax to 01245324422.

Quality Control Manager: Ron Brown ronbrown@smiths-env.com

User Details

User Name Mr/Mrs/Miss/Ms/Other

Initials Surname

Address

.....

..... Post Code:

Telephone:

Product & Model installed (e.g. Space Saver SS5)

Room Installed (e.g. Kitchen):

Your details will only be held by Smiths Environmental Products Ltd and used solely to provide customer services and product information.
 If you do not wish to be contacted, please put an x in the box.

Installer Details

Company name:

Principal contact: Mr/Mrs/Miss/Ms/Other:

Initials: Surname:

Address:

.....

..... Post Code:

Telephone:

Date of installation/...../.....

Room Installed (e.g. Kitchen):

Your details will only be held by Smiths Environmental Products Ltd and used solely to provide customer services and product information.
 If you do not wish to be contacted, please put an x in the box.