

Accessories

By fitting optional equipment this product can operate automatically under normal running conditions. The optional controls fit within the casing of the unit and are supplied with easy to fit instructions.

Wall Mounted Controller WMCEC

This enables the end user to control the fan speed from a wall mounted control.

Plinth to suit Caspian Universal CCLP

Where the product is installed floor level, the plinth will raise the unit 150mm above the floor. (Available in black & white)

Air inlet filters for all models.

For accessories or spares please contact either your supplier or Smith's Environmental Products Ltd.

Technical designation 60, 90, 120, 150, 180 LST

Products with this symbol (crossed out wheelie bin) cannot be disposed as household waste. Old electrical and electronic equipment must be recycled at a facility capable of handling these products and their waste by-products. If you are purchasing replacement equipment your retailer may offer a 'take back' scheme, or will be able to give details of the nearest approved authorised treatment facility. Proper recycling and waste disposal will help conserve resources whilst preventing detrimental effects on our health and the environment.

WEEE Registered Code : WEE/ED0093VW



RECYCLE



ISO 9001
Registered Firm



Smith's Environmental Products Ltd

Blackall Industrial Estate, South Woodham Ferrers, Chelmsford, Essex, CM3 5UW
Tel: 01245 324900 Fax: 01245 324422

Sales: sales@SmithsEP.co.uk General Information E-mail: info@SmithsEP.co.uk Web: www.SmithsEP.co.uk

For Ireland (Republic & Northern), contact MT Agencies on 00 353 1 864 3363

In light of our policy of continuous development Smith's Environmental Products Ltd reserve the right to alter specifications without prior notice.



LST Caspian 60, 90, 120, 150 & 180 Series Fan Convectors

Suitable for Low Level Installation Only

Installation & User Guide



User Information.

- This appliance can be used by children aged from 8 years and above and persons with reduced physical, sensory or mental capabilities or lack of experience and knowledge if they have been given supervision or instruction concerning use of the appliance in a safe way and understand the hazards involved. Children shall not play with the appliance. Cleaning and user maintenance shall not be made by children without supervision
- A means for disconnection from the supply mains having a contact separation in all poles that provides full disconnection under overvoltage category III conditions must be incorporated in the fixed wiring in accordance with the wiring rules.
- Ensure that the fan convector is switched-off before opening the cover.

Introduction

Testing undertaken by BSRIA conforms these heaters comply with DHSS Engineering and Data DN4 and NHS Estates Health Guidance Note 'Safe Hot Water and Surface Temperature' (1998).

These heaters are designed as a low level mounted product with air outlet discharge from the top of the unit. LST function ensures the surface and grille temperature does not exceed 43°C by measuring leaving air temperature and modulating the flow through the heat exchanger.

These heaters must not be installed in wet rooms or other high humidity areas.

These heaters are designed for use on standard two-pipe pumped central heating systems with a maximum water temperature of 86° C and a maximum pressure of 6 bar (88lbs/in²). Pipe connections are 22mm, **Flow direction must follow that shown on the body of the valve.**

These heaters are classified as a fixed appliance and the electrical connection should be via a 3A fused spur. The fused spur must **not** be directly below the heater but should be accessible after completion of the installation. All heaters must be earthed.

This heater is fitted with an integral room thermostat.

This heater is fitted with an air outlet thermostat pre-set to 34°C; **and should not be adjusted above 35°C.**

To avoid the possibility of vibration these units must be fitted to a flat even surface.

These heaters are fitted with low temperature cut out stats and will not operate until a water temperature of approximately 35°C is achieved.

If desired a remote room thermostat can be used in conjunction with this heater. Refer to the manufacturer's instructions supplied with the thermostat.

Please note the guarantee may be invalidated if this product is not installed and used in accordance with these instructions.

For further details please contact our Technical Support on 01245 324560.

Installation Guide

1. Unlock and lower the front access panel using the keys supplied.

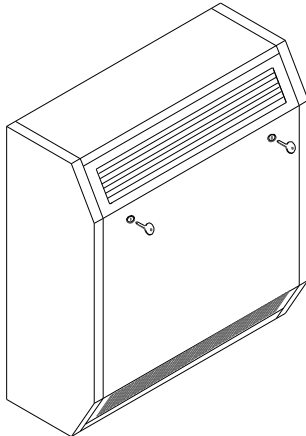

Fault Finding

1. The fan does not run on any speed setting.
 - a. Check the power supply is switched ON.
 - b. Check the fuse in the fused spur.
 - c. Check the wiring at the fused spur.
 - d. Check thermostat is calling for heat
 - e. Check the central heating is switched ON and hot water flowing through system.
 - f. Vent any trapped air from the system (with the heating system turned OFF).
2. No heat output.
 - a. Vent any trapped air from the system (with the heating system turned OFF).
 - b. Check the central heating is switched ON and hot water flowing through system.
 - c. Check thermostat is calling for heat
 - d. Balance the central heating system if installed on the same circuit as panel radiators and increase the circulating pump speed if required.
 - e. Increase the boiler water temperature.

Providing the power supply is switched on and the room thermostat is calling for heat the heater will switch on and off automatically with the central heating system.

In the event of difficulty please contact our technical help-line on 01245 324560. It would be helpful if you do not disconnect the heater from the central heating system prior to calling.

Maintenance.

Warning! Isolate from the electrical supply before performing any work on the unit.

The internal air filter is removable for servicing. To gain access to the filter, unlock and lower the front access panel, remove the 2 screws from the filter enclosure panel and lift out. Carefully lift and remove filter (see fig 3). The filter should be gently tapped to remove any accumulated dust and vacuumed if necessary.

The coil fins are delicate so take care and only use a soft brush or vacuum cleaner to remove any dust that may have accumulated.

To replace filter, reverse the removal instructions and ensure the lower front access panel is securely locked.

The fan(s) and motors should not require servicing. Please contact your supplier if damaged.

Please note in the event of an engineer's visit, Smith's Environmental Products Ltd reserve the rights to apply a call-out charge should the fault prove to be with the system or installation and not the heater appliance.

**Caspian CL 60
Wiring Diagram**

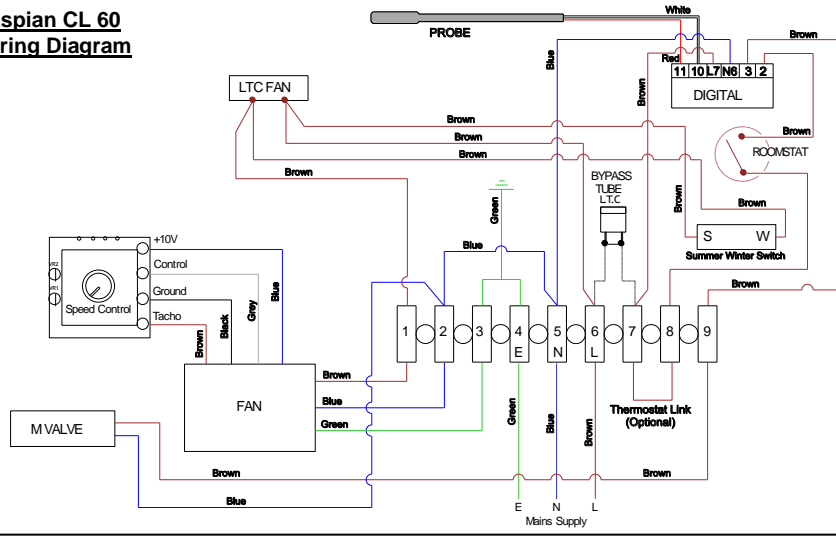

2. Fix the unit to the wall via suitable fixings.

Model	A	B
60	595	470
90	895	770
120	1195	1070
150	1495	1370
180	1795	1670

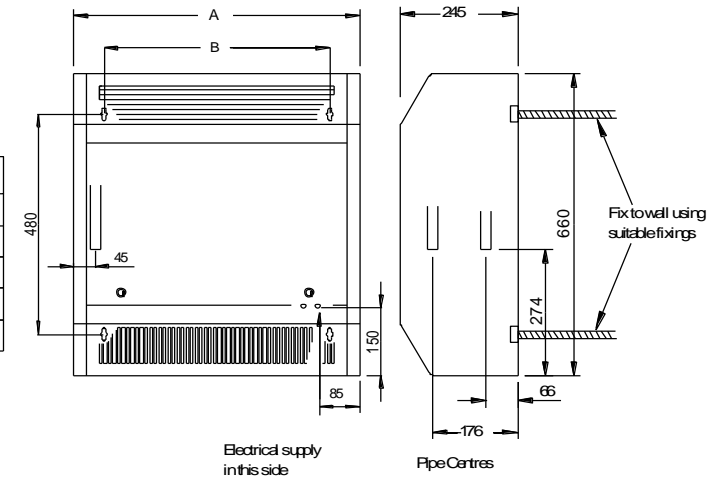

**Caspian CL 90/ 120
Wiring Diagram**

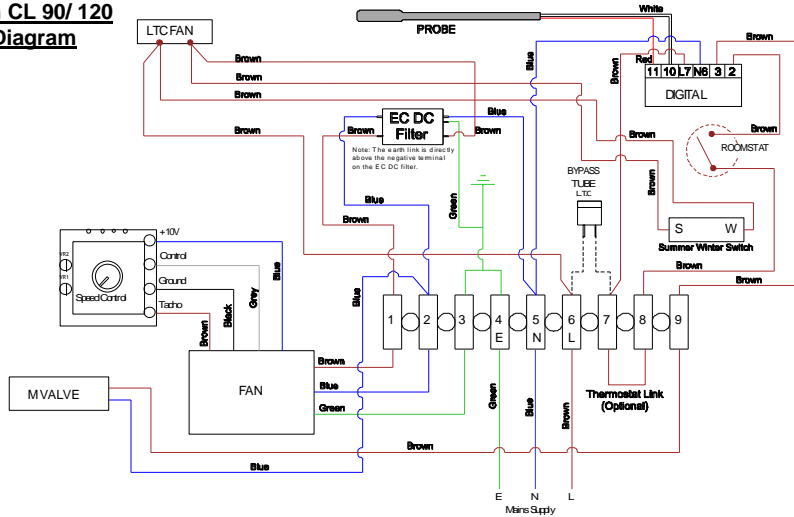

3. Connect the heating system flow and return pipes to the heater pipe work. Pipe entry/ exit can be made through either the back of the unit or by using the Pipe Knockouts on the bottom of the unit (See Fig 3). Do not use soldered fittings to connect the heater pipe work as the heat generated may cause damage to internal wiring and components.

We recommend the use of full-flow service valves. The valves should be accessible after completion of the installation. We also advise the fitting of an air vent at the highest point on either the flow or return pipe to remove any air trapped within the system.

4. Open the full flow service valves (see above) and check for water leaks. Remove any trapped air from the unit via the built in bleed screws as shown in the diagram below.

Note: Ensure the motorised valve is set to the Auto position.

Fig 3

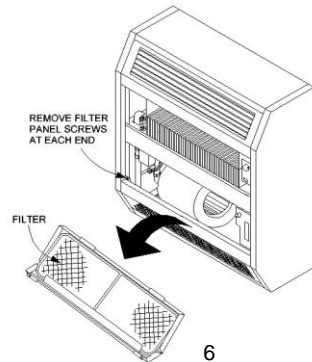

6

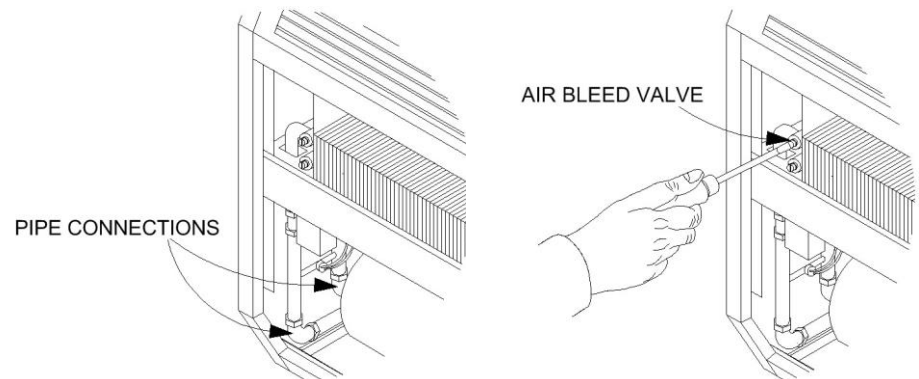

5. Isolate the electrical supply

6. Connect the power supply from the fused spur (3 Amp) to the heater terminal block marked **Supply E N L** (see fig 2) via the cable entry hole in the top chassis of the heater. The fused spur must not be directly below the heater and must be accessible after the installation is complete. All electrical work should be carried out in accordance with current IEEE regulations.

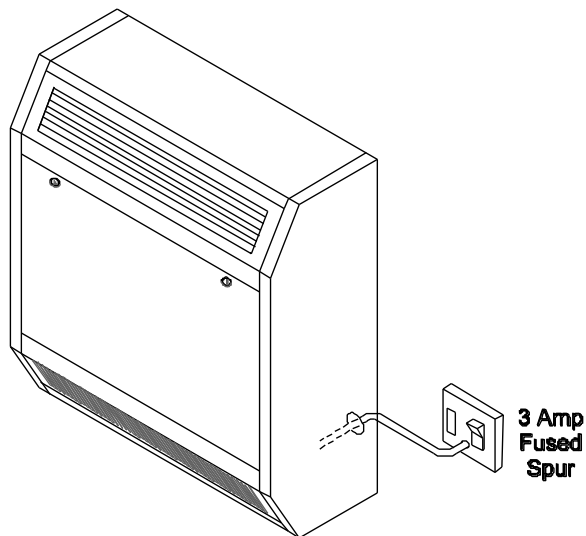

7. To connect a room thermostat (not supplied) to the connection block on the heater remove link and connect to terminals 7 & 8.

For further information refer to the room thermostat manufacturers instructions.

Fig 1

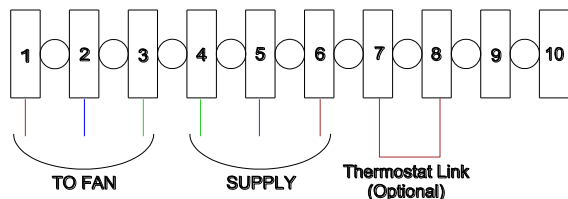

Commissioning

1. Turn on the electrical supply at the fused spur.
2. Turn the thermostat control (if fitted) to maximum.
3. Turn on the central heating system

4. If these heaters are installed on the same circuit as panel radiators balance the central heating system.
5. If the installation is working correctly remember to reset the thermostat control to its required setting.

6. Set the fan speed control to the desired position (see fig 2)

(Note To decrease motorised valve cycles it is recommended that the flow is reduced. (Please ensure adequate flow through heater).)

7. Lift up and close front access panel, ensure this is secure and locked in place with keys provided.

8. Please leave this Installation & User Guide with the user for future reference.

Heat Output Performance			
LST Model	Heat Output (kW)	Heat Output (kW)	Heat Output (kW)
	High	Medium	Low
60	2.16	1.58	1.00
90	3.94	3.46	2.99
120	5.71	5.35	4.98
150	7.20	6.70	6.20
180	8.7	8.2	7.7

Heat outputs based at 80°C mean water temperature, with an entering air temperature of 20°C, in accordance with BS EN442.

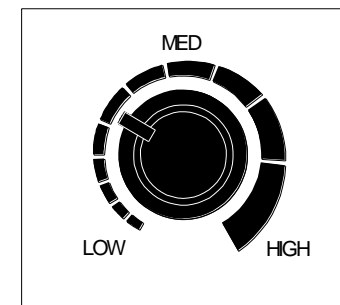

Fig 2

Heating – see below

Ensure the central heating system is **ON**. Switch on the power supply to the unit. Set the thermostat control (if fitted) to the desired temperature. Providing the water temperature in the central heating system is more than 35°C and the thermostat (if fitted) is calling for heat the product will switch on.

Note: Achieving higher output than shown in the above table will not be possible by increasing flow rate, this is because due to LST function of the heater. To achieve higher than shown outputs increase fan speed.

It is recommended that the model chosen is capable of maintaining the calculated heat loss at medium heat output enabling the high speed setting to be used for faster heat up and the low speed for maintaining temperature.

Guarantee Statement

Thank you for purchasing a Smith's heater.

It has been designed and manufactured to the highest quality standards to ensure it gives you efficient and trouble-free service for many years.

To back up our commitment, included with your product is a **free five year parts and labour guarantee.**

This gives you peace of mind that in the unlikely event of the product failing within the first five years, we will repair or replace the product completely free of charge provided the product has been installed, used and maintained in accordance with the instructions.

It is important to register within 7 days. This will ensure you receive a prompt and efficient service, if your product requires attention within the guarantee period. If you do not register your product, you will be required to produce a proof of purchase prior to receiving this service.

If you experience any problems with the use of your product, please contact our **after-sales office** on 01245 324560.

Smith's Environmental Products Ltd manufactures a complete range of heaters for domestic and commercial applications.

If you require any further information, please contact us on **01245 324900** or visit our website at **www.SmithsEP.com**.

Your statutory rights are not affected by this guarantee.

Please pull this registration card from the booklet and fill in all parts and return.

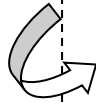

please fold along here



**Please
affix
stamp
here**

Smith's Environmental Products Ltd
Units 1 & 2 Blackall Industrial Estate
Hamberts Road
South Woodham Ferrers
Chelmsford
Essex
CM3 5UW

**Guarantee Registration Card
& Customer Satisfaction Survey**

Dear Customer

We hope our product suits all your requirements; it would help us immensely if you could find the time to fill in this form, your response will help us maintain the quality standards we all expect in today's climate.

Customer name _____ Date ____/____/____

Email Address _____@_____

Product Name _____

Tick as appropriate

	V Good	Good	Fair	Poor
Product	<input type="checkbox"/>	<input type="checkbox"/>	<input type="checkbox"/>	<input type="checkbox"/>
Delivery	<input type="checkbox"/>	<input type="checkbox"/>	<input type="checkbox"/>	<input type="checkbox"/>
Sales & Ordering	<input type="checkbox"/>	<input type="checkbox"/>	<input type="checkbox"/>	<input type="checkbox"/>
Response to any problems	<input type="checkbox"/>	<input type="checkbox"/>	<input type="checkbox"/>	<input type="checkbox"/>

Comments _____

Thank you for your time to fill in this survey, the response will help us to serve your needs more effectively. Please return by fax to 01245324422.

Quality Control Manager: Ron Brown ron.brown@smithsep.co.uk

User Details

User Name Mr/Mrs/Miss/Ms/Other

Initials Surname

Address

.....

..... Post Code:

Telephone:

Product & Model installed (e.g. Space Saver SS5)

.....

Room Installed (e.g. Kitchen):

Your details will only be held by Smiths Environmental Products Ltd and used solely to provide customer services and product information.
 If you do not wish to be contacted, please put an x in the box.

Installer Details

Company name:

Principal contact: Mr/Mrs/Miss/Ms/Other:

Initials: Surname:

Address:

.....

..... Post Code:

Telephone:

Date of installation/...../.....

Room Installed (e.g. Kitchen):

Your details will only be held by Smiths Environmental Products Ltd and used solely to provide customer services and product information.
 If you do not wish to be contacted, please put an x in the box.